

PRELIMINARY DRAWING - FOR LAYOUT PURPOSES ONLY

REVISIONS			
REV	DESCRIPTION	DATE	BY

NOTE 1: Do not scale drawing. This drawing is for general truck configuration only. All items and dimensions shown are approximate and may vary with final production. The drawing may not provide illustration for all items in the specification. In all situations where the drawing may contradict the specifications, the specifications shall prevail. This drawing and all data herein are provided as confidential materials and shall not be reproduced without written consent of the manufacturer.

NOTE 2: Chassis frame height will change due to axle characteristics, loading and tire dimensions which will effect the overall height dimension shown. Any overall height restrictions should take this into consideration and allow approximately 2-3 inches of tolerance.

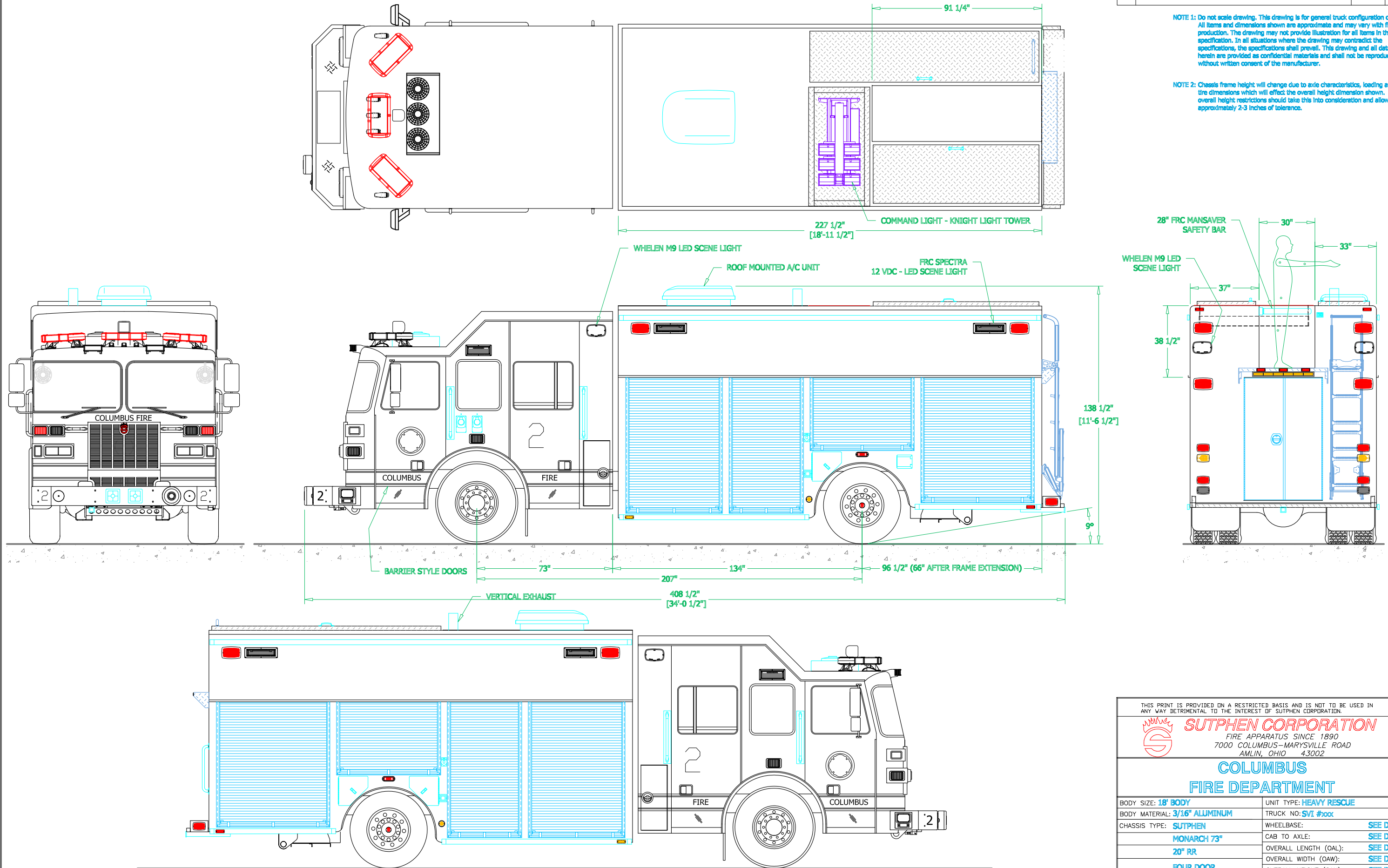

THIS PRINT IS PROVIDED ON A RESTRICTED BASIS AND IS NOT TO BE USED IN ANY WAY DETRIMENTAL TO THE INTEREST OF SUTPHEN CORPORATION.

SUTPHEN CORPORATION
 FIRE APPARATUS SINCE 1890
 7000 COLUMBUS-MARYSVILLE ROAD
 AMLIN, OHIO 43002

COLUMBUS FIRE DEPARTMENT

BODY SIZE: 18' BODY	UNIT TYPE: HEAVY RESCUE
BODY MATERIAL: 3/16" ALUMINUM	TRUCK NO: SVI #000
CHASSIS TYPE: SUTPHEN	WHEELBASE: SEE DWG
MONARCH 73"	CAB TO AXLE: SEE DWG
20" RR	OVERALL LENGTH (OAL): SEE DWG
FOUR DOOR	OVERALL WIDTH (OAW): SEE DWG
	OVERALL HEIGHT (OAH): SEE DWG

DRAWN BY: Daves DATE: January 25, 2012 SCALE: 4 1/4" = 1'-0"
 DRAWING NO: Columbus_DH_HR_PreCon1 SHEET 1 OF 3

PRELIMINARY DRAWING - FOR LAYOUT PURPOSES ONLY

REVISIONS			
REV	DESCRIPTION	DATE	BY

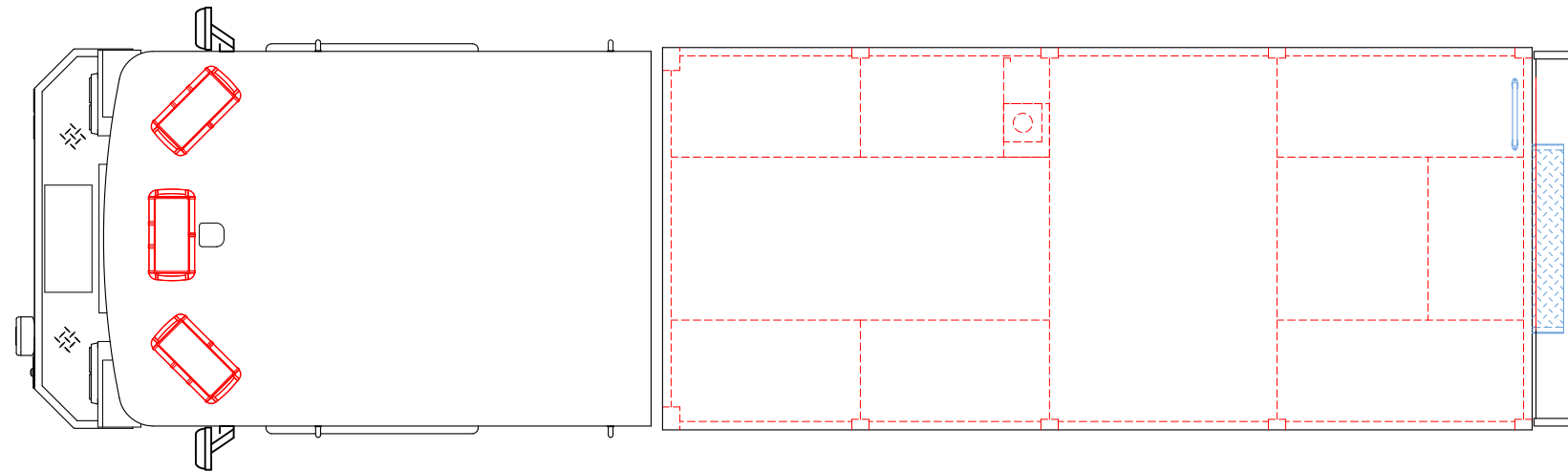

LEFT SIDE COMPARTMENTATION				
COMPT	DOORS	OPENING DIMENSIONS	INSIDE DIMENSIONS	VOLUME
L1	ROLL UP	42" w X 69" h	49" w X 76" h X 26 1/2" d	57 CU. FT.
L2	ROLL UP	42" w X 69" h	49" w X 76" h X 26 1/2" d	57 CU. FT.
L3	ROLL UP	52" w X 35" h	59" w X 43" h X 26 1/2" d	39 CU. FT.
L4	ROLL UP	57" w X 63" h	57" w X 63" h X 26 1/2" d	55 CU. FT.

RIGHT SIDE COMPARTMENTATION				
COMPT	DOORS	OPENING DIMENSIONS	INSIDE DIMENSIONS	VOLUME
R1	ROLL UP	42" w X 69" h	49" w X 76" h X 26 1/2" d	57 CU. FT.
R2	ROLL UP	42" w X 69" h	49" w X 76" h X 26 1/2" d	57 CU. FT.
R3	ROLL UP	52" w X 35" h	59" w X 43" h X 26 1/2" d	39 CU. FT.
R4	ROLL UP	57" w X 63" h	57" w X 63" h X 26 1/2" d	55 CU. FT.

REAR COMPARTMENT				
COMPT	DOORS	OPENING DIMENSIONS	INSIDE DIMENSIONS	VOLUME
RC1	HINGED	37" w X 65" h	42" w X 69" h X 64" d	107 CU. FT.

UPPER BODY COMPARTMENTS				
COMPT	DOORS	OPENING DIMENSIONS	INSIDE DIMENSIONS	VOLUME
STREETSIDE	HINGED	89" w X 27" h	89" w X 31" h X 29" d	46 CU. FT.
CURBSIDE	HINGED	123" w X 27" h	123" w X 31" h X 29" d	65 CU. FT.

TOTAL EXTERIOR COMPARTMENT STORAGE: 634 CU.FT.

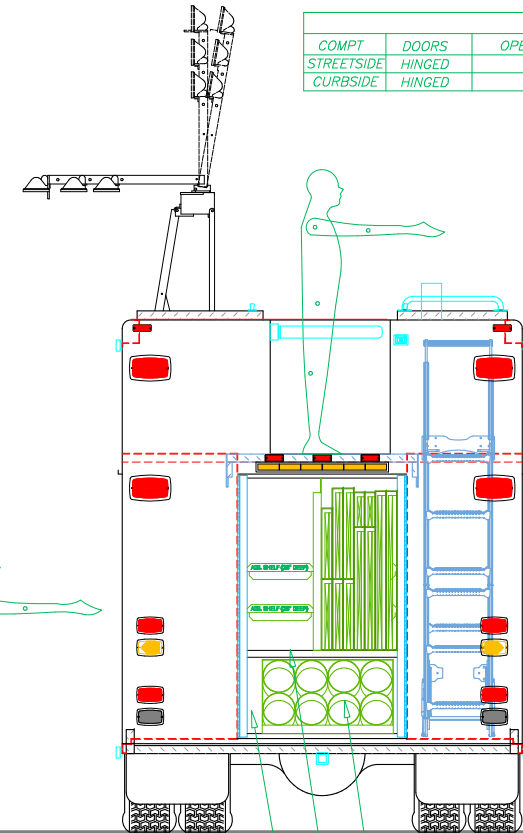

EXTERIOR COMPARTMENT CROSS-SECTION

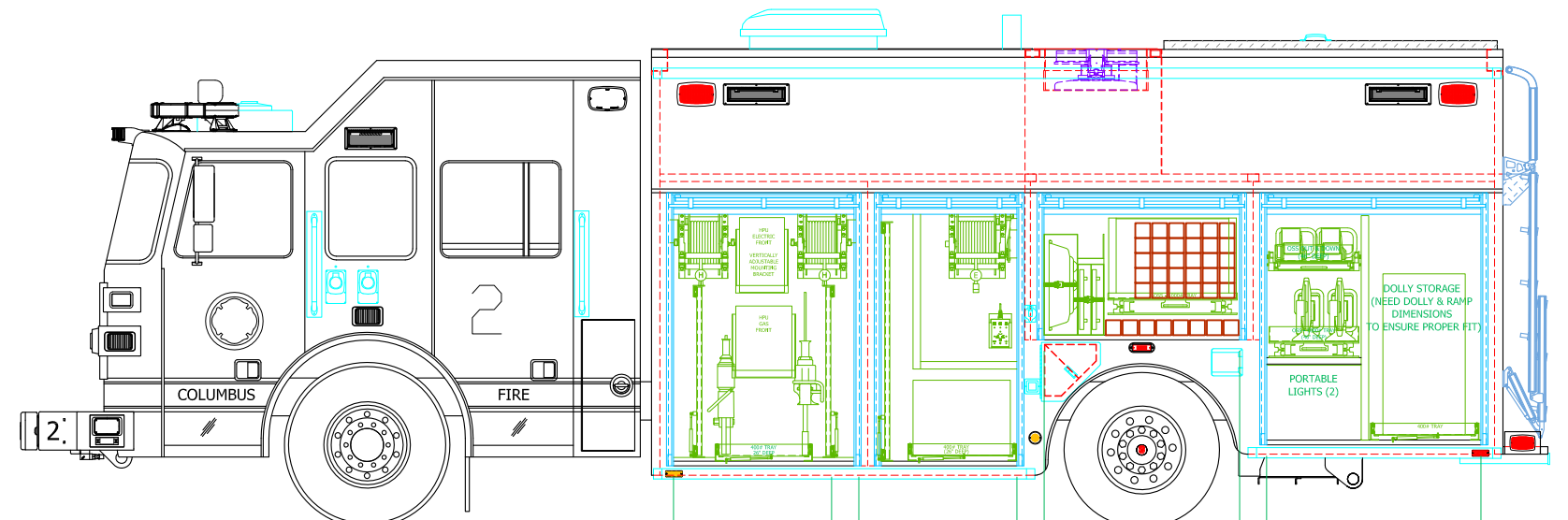
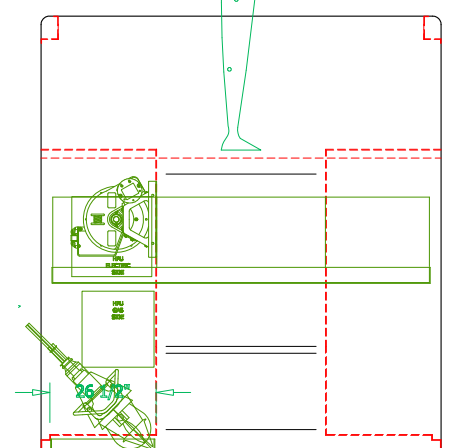

125 1/2"
123 1/4"
42 1/4"
42 1/4"
52 1/4"
57 1/4"

WINCH 12VDC POWER POINT
SCBA BOTTLE STORAGE
AIRBAG STORAGE MODULE

NOTE 1: Do not scale drawing. This drawing is for general truck configuration only. All items and dimensions shown are approximate and may vary with final production. The drawing may not provide illustration for all items in the specification. In all situations where the drawing may contradict the specifications, the specifications shall prevail. This drawing and all data herein are provided as confidential materials and shall not be reproduced without written consent of the manufacturer.

THIS PRINT IS PROVIDED ON A RESTRICTED BASIS AND IS NOT TO BE USED IN ANY WAY DETRIMENTAL TO THE INTEREST OF SUTPHEN CORPORATION.

SUTPHEN CORPORATION
FIRE APPARATUS SINCE 1890
7000 COLUMBUS-MARYSVILLE ROAD
AMLIN, OHIO 43002

COLUMBUS FIRE DEPARTMENT

BODY SIZE: 18' BODY	UNIT TYPE: HEAVY RESCUE
BODY MATERIAL: 3/16" ALUMINUM	TRUCK NO: SVI #3000
CHASSIS TYPE: SUTPHEN MONARCH 73" 20" RR	WHEELBASE: SEE DWG
	CAB TO AXLE: SEE DWG
	OVERALL LENGTH (OAL): SEE DWG
	OVERALL WIDTH (OAW): SEE DWG
	OVERALL HEIGHT (OAH): SEE DWG

FOUR DOOR

DRAWN BY: Deves DATE: January 25, 2012 SCALE: 4 1/4" = 1'-0"

DRAWING NO: Columbus_DH_HR_PreCon1 SHEET 2 OF 2

CAB TILT CONTROLLER

PRELIMINARY DRAWING - FOR LAYOUT PURPOSES ONLY

REVISIONS			
REV	DESCRIPTION	DATE	BY

NOTE 1: Do not scale drawing. This drawing is for general truck configuration only. All items and dimensions shown are approximate and may vary with final production. The drawing may not provide illustration for all items in the specification. In all situations where the drawing may contradict the specifications, the specifications shall prevail. This drawing and all data herein are provided as confidential materials and shall not be reproduced without written consent of the manufacturer.

PLAN VIEW
CROSS-SECTION

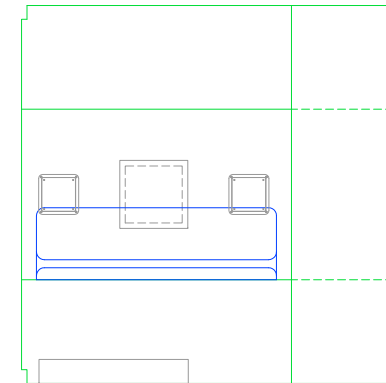

STREETSIDE INTERIOR
CROSS-SECTION

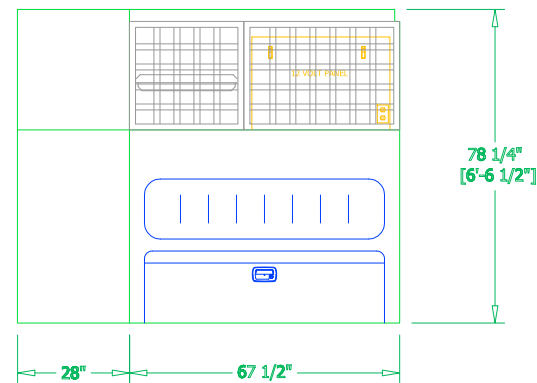

REAR VIEW
CROSS-SECTION

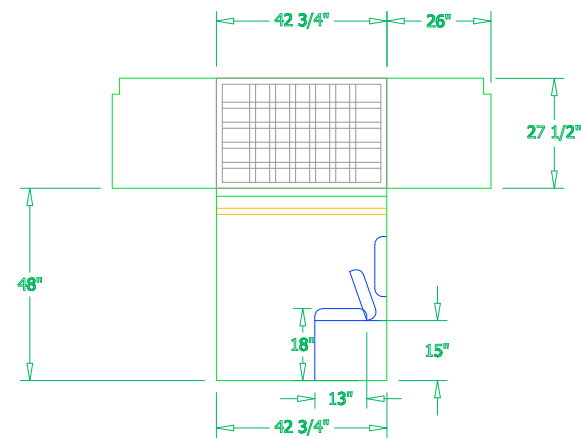

CURBSIDE INTERIOR
CROSS-SECTION

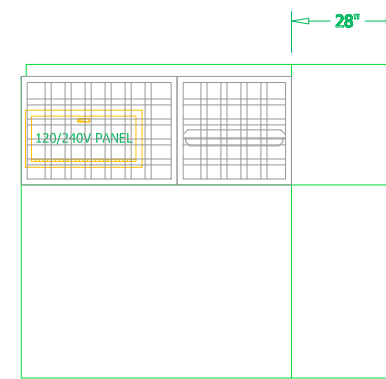

REAR VIEW
CROSS-SECTION

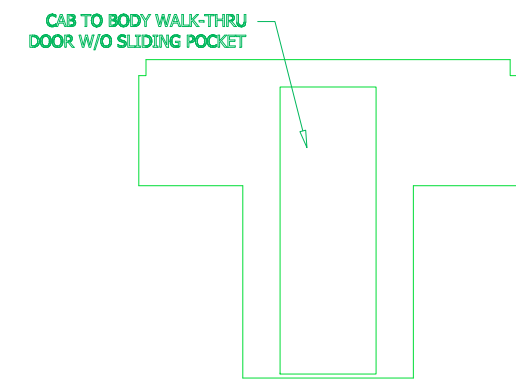

THIS PRINT IS PROVIDED ON A RESTRICTED BASIS AND IS NOT TO BE USED IN ANY WAY DETRIMENTAL TO THE INTEREST OF SUTPHEN CORPORATION.

SUTPHEN CORPORATION
FIRE APPARATUS SINCE 1890
7000 COLUMBUS-MARYSVILLE ROAD
AMLIN, OHIO 43002

**COLUMBUS
FIRE DEPARTMENT**

BODY SIZE: 18' BODY	UNIT TYPE: HEAVY RESCUE
BODY MATERIAL: 3/16" ALUMINUM	TRUCK NO: SVI #3000
CHASSIS TYPE: SUTPHEN	WHEELBASE: SEE DWG
MONARCH 73"	CAB TO AXLE: SEE DWG
20" RR	OVERALL LENGTH (OAL): SEE DWG
FOUR DOOR	OVERALL WIDTH (OAW): SEE DWG
	OVERALL HEIGHT (OAH): SEE DWG

DRAWN BY: Deves DATE: January 25, 2012 SCALE: 4 1/4" = 1'-0"
DRAWING NO: Columbus_DH_HR_PreCon1 SHEET 2 OF 2