

PRELIMINARY DRAWING - FOR LAYOUT PURPOSES ONLY

REVISIONS			
REV	DESCRIPTION	DATE	BY

NOTE 1: Do not scale drawing. This drawing is for general truck configuration only. All items and dimensions shown are approximate and may vary with final production. The drawing may not provide illustration for all items in the specification. In all situations where the drawing may contradict the specifications, the specifications shall prevail. This drawing and all data herein are provided as confidential materials and shall not be reproduced without written consent of the manufacturer.

NOTE 2: Chassis frame height will change due to axle characteristics, loading and the dimensions which will effect the overall height dimension shown. Any overall height restrictions should take this into consideration and allow approximately 2-3 inches of tolerance.

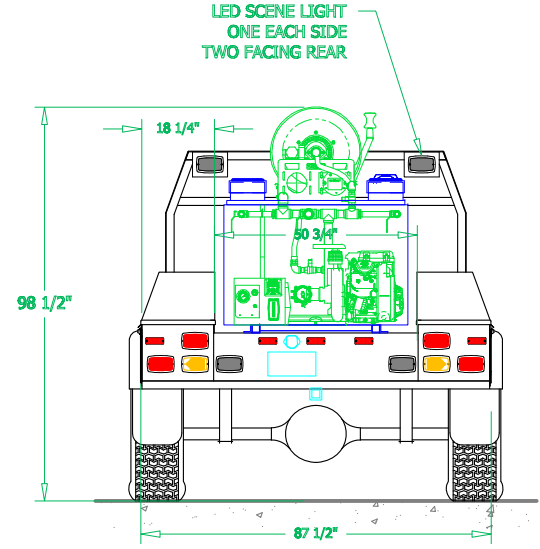
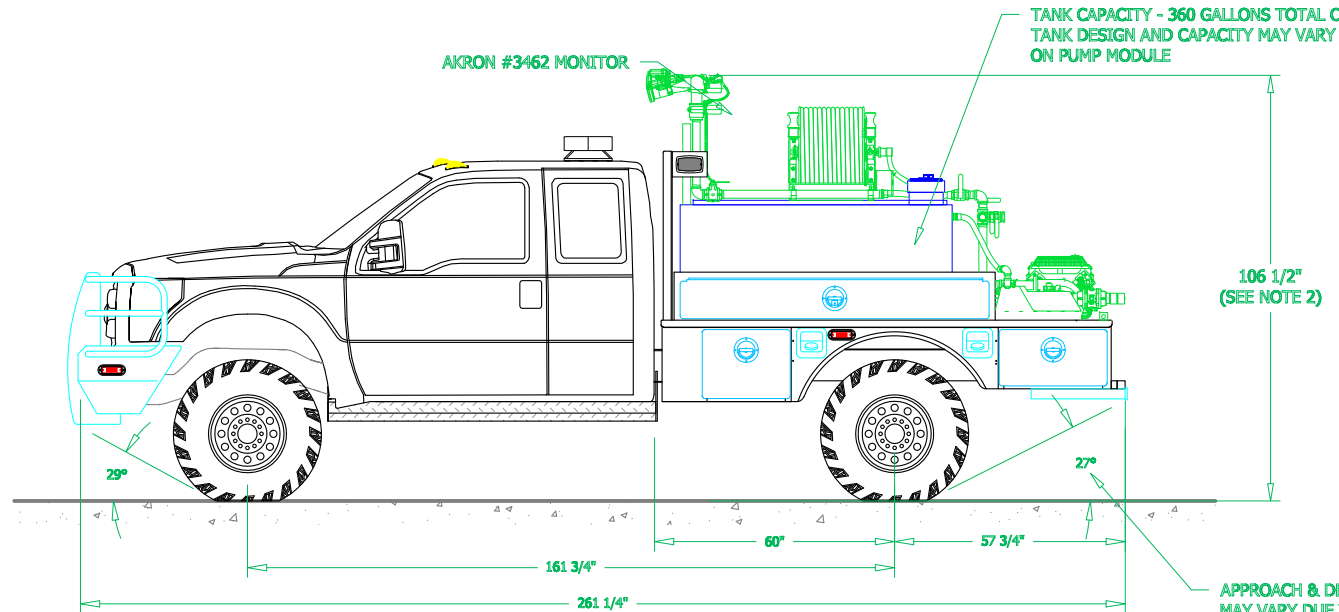
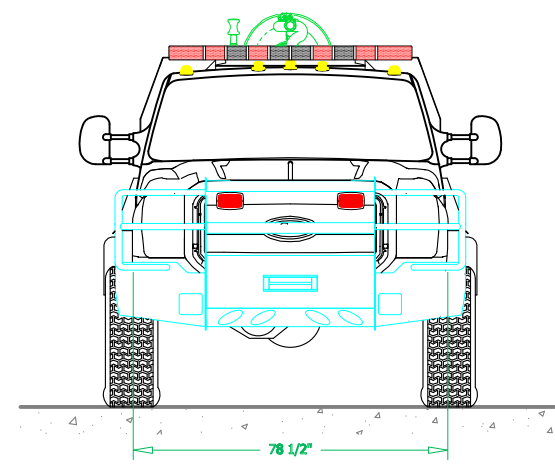
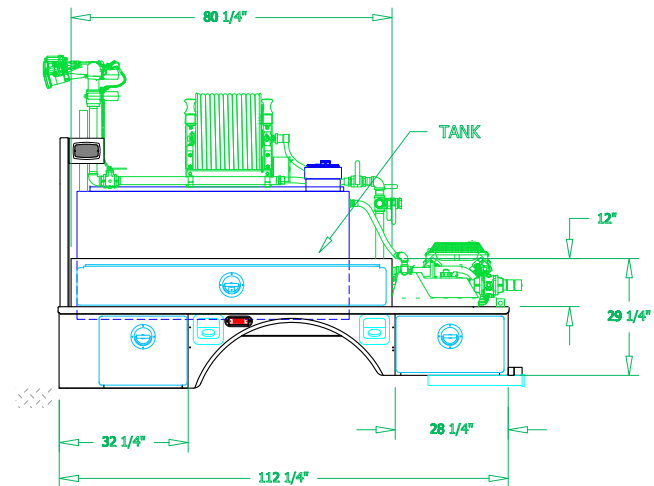

TANK CAPACITY - 360 GALLONS TOTAL CAPACITY
TANK DESIGN AND CAPACITY MAY VARY DEPENDING
ON PUMP MODULE

AKRON #3462 MONITOR

APPROACH & DEPARTURE ANGLE
MAY VARY DUE TO CHASSIS
INFORMATION AND AFTERMARKET
FRONT BUMPER NOT KNOW
AT THIS TIME

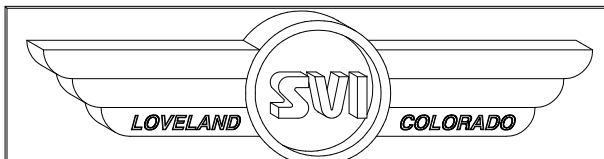
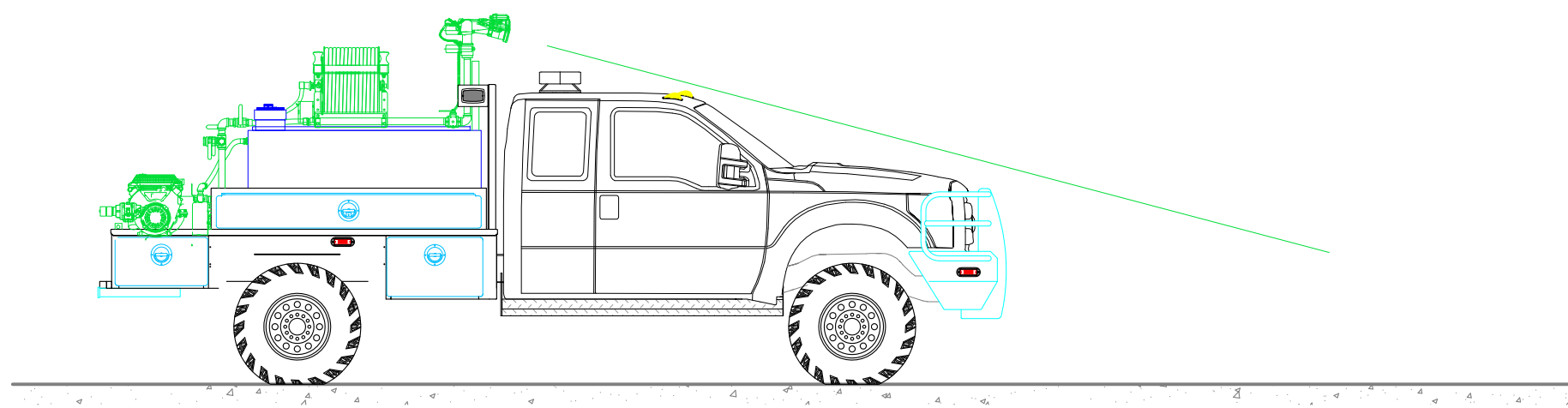

SVI FIRE & RESCUE TRUCKS
1511 E. 11th STREET, LOVELAND, CO 80537 PHONE 970-667-5146, FAX 970-667-3343

EDMONTON
FIRE DEPARTMENT

BODY SIZE: 10' BODY	UNIT TYPE: TYPE 6 (UTILITY)
BODY MATERIAL: ---	TRUCK NO: SVI #xxx
CHASSIS TYPE: SUPERDUTY	WHEELBASE: SEE DWG
---	CAB TO AXLE: SEE DWG
---	OVERALL LENGTH (OAL): SEE DWG
---	OVERALL WIDTH (OAW): SEE DWG
---	OVERALL HEIGHT (OAH): SEE DWG