

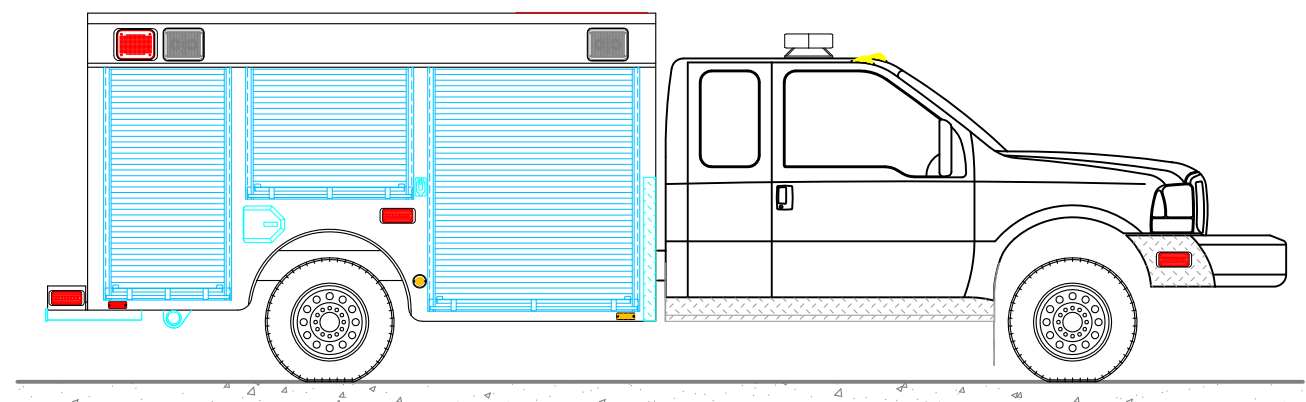
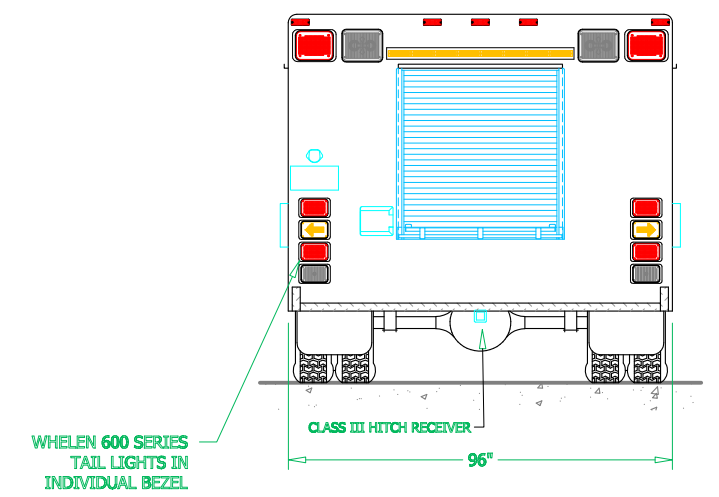
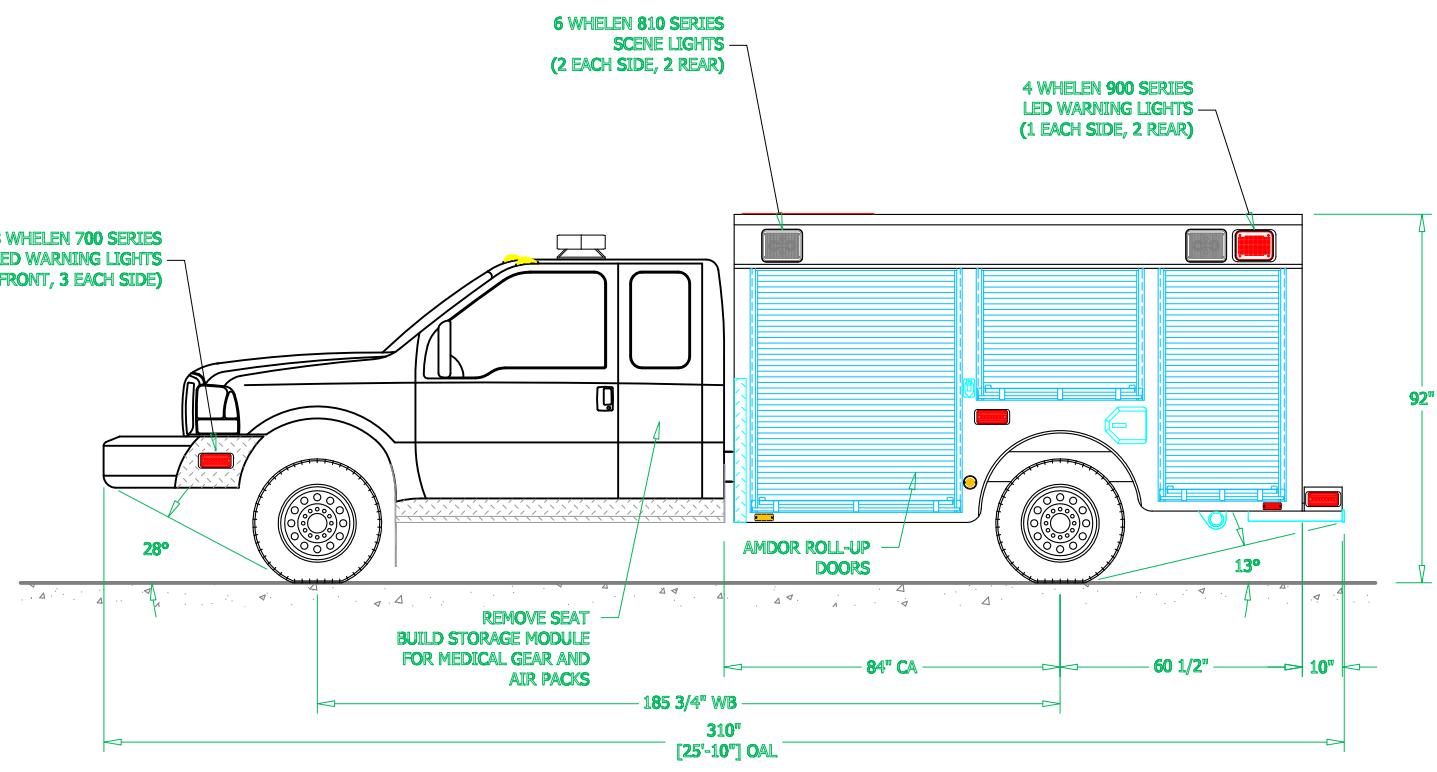
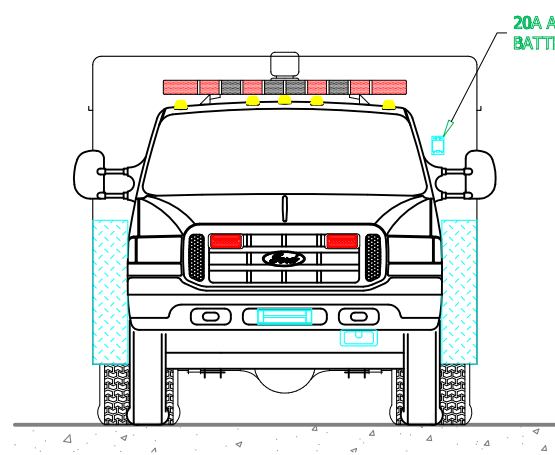
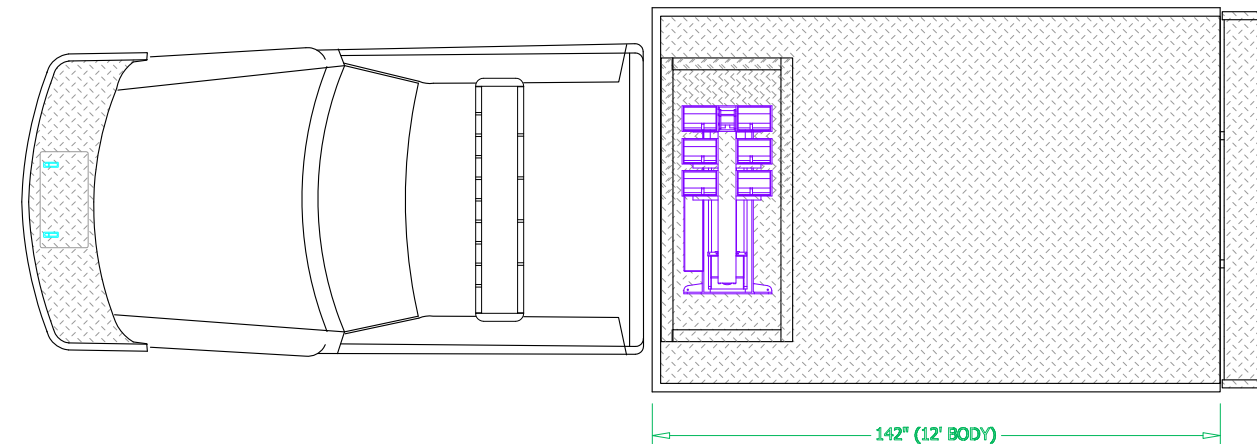

PRELIMINARY DRAWING - FOR LAYOUT PURPOSES ONLY

| REVISIONS | | | |
|-----------|-------------|------|----|
| REV | DESCRIPTION | DATE | BY |
| | | | |

NOTE 1: Do not scale drawing. This drawing is for general truck configuration only. All items and dimensions shown are approximate and may vary with final production. The drawing may not provide illustration for all items in the specification. In all situations where the drawing may contradict the specifications, the specifications shall prevail. This drawing and all data herein are provided as confidential materials and shall not be reproduced without written consent of the manufacturer.

NOTE 2: Chassis frame height will change due to axle characteristics, loading and the dimensions which will effect the overall height dimension shown. Any overall height restrictions should take this into consideration and allow approximately 2-3 inches of tolerance.





LOVELAND SVI COLORADO

SVI FIRE & RESCUE TRUCKS
1511 E. 11th STREET, LOVELAND, CO 80537 PHONE 970-667-5146, FAX 970-667-3343

FREDERICTON FIRE DEPARTMENT

| | |
|-------------------------------|-------------------------------|
| BODY SIZE: 12' BODY | UNIT TYPE: LIGHT RESCUE |
| BODY MATERIAL: 3/16" ALUMINUM | TRUCK NO: SVI #xxx |
| CHASSIS TYPE: FORD | WHEELBASE: SEE DWG |
| F550 4x4 | CAB TO AXLE: SEE DWG |
| - | OVERALL LENGTH (OAL): SEE DWG |
| FOUR DOOR | OVERALL WIDTH (OAW): SEE DWG |
| | OVERALL HEIGHT (OAH): SEE DWG |

DRAWN BY: HJR DATE: December 2, 2011 SCALE: 1/4" = 1'-0"

DRAWING NO: Fredericton_NB_LR_Prelim1 SHEET 1 OF 2

PRELIMINARY DRAWING - FOR LAYOUT PURPOSES ONLY

| REVISIONS | | | |
|-----------|-------------|------|----|
| REV | DESCRIPTION | DATE | BY |
| | | | |

NOTE 1: Do not scale drawing. This drawing is for general truck configuration only. All items and dimensions shown are approximate and may vary with final production. The drawing may not provide illustration for all items in the specification. In all situations where the drawing may contradict the specifications, the specifications shall prevail. This drawing and all data herein are provided as confidential materials and shall not be reproduced without written consent of the manufacturer.

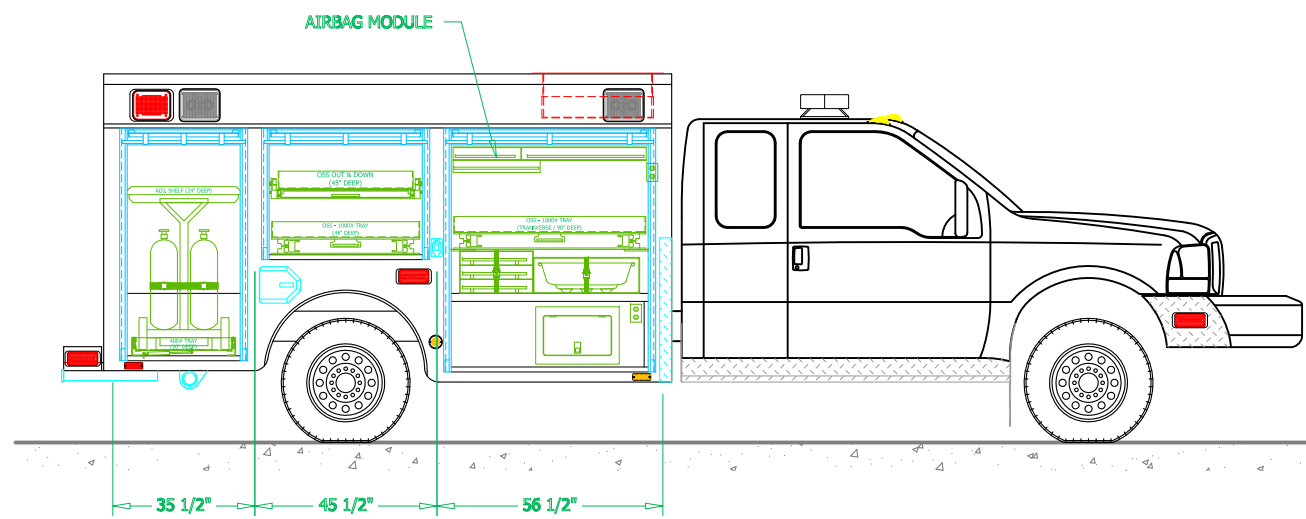
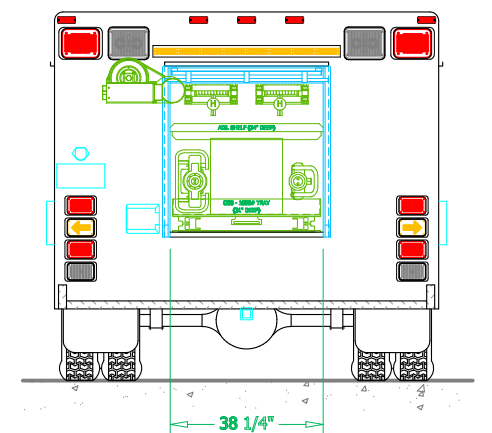
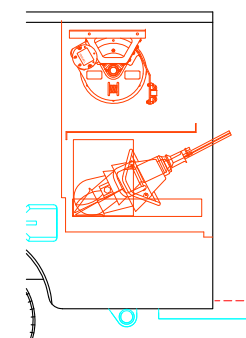
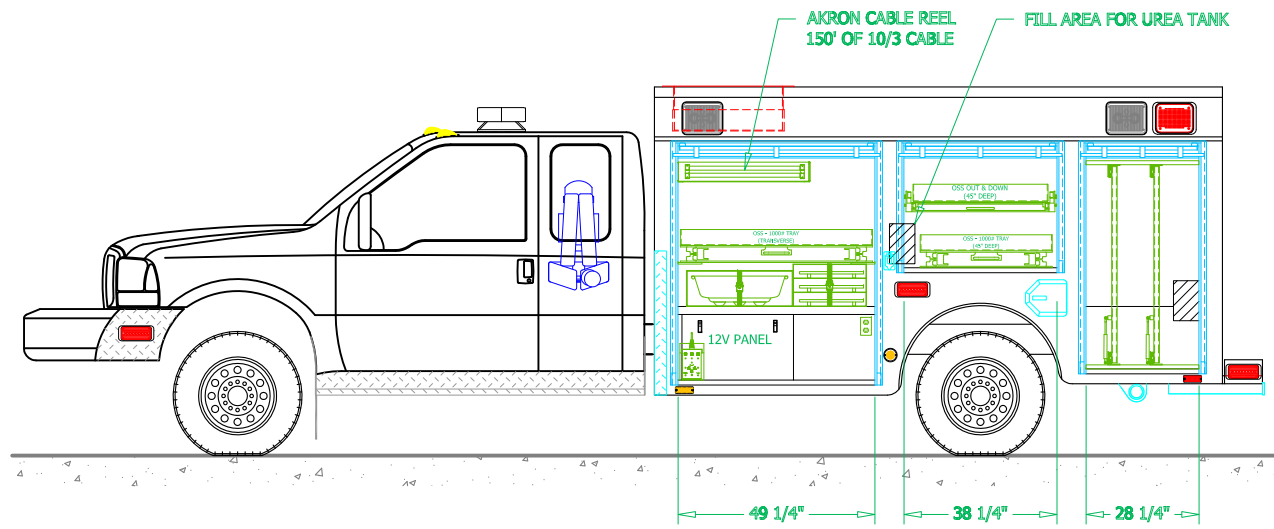
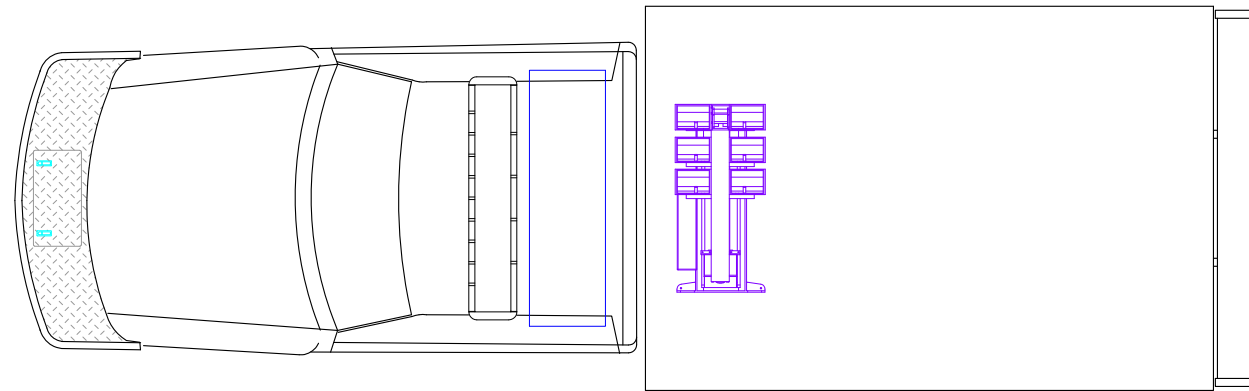

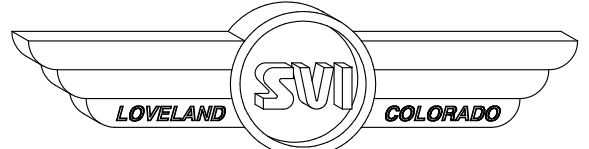

LOVELAND SVI COLORADO

SVI FIRE & RESCUE TRUCKS
 1511 E. 11th STREET, LOVELAND, CO 80537 PHONE 970-667-5146, FAX 970-667-3343

**FREDERICTON
 FIRE DEPARTMENT**

| | | |
|--|------------------------|---------------------|
| DRAWN BY: HJR | DATE: December 2, 2011 | SCALE: 1/4" = 1'-0" |
| DRAWING NO: Frederickton_NB_LR_Prelim1 | SHEET 2 OF 2 | |