

PRELIMINARY DRAWING - FOR LAYOUT PURPOSES ONLY

REVISIONS			
REV	DESCRIPTION	DATE	BY

NOTE 1: Do not scale drawing. This drawing is for general truck configuration only. All items and dimensions shown are approximate and may vary with final production. The drawing may not provide illustration for all items in the specification. In all situations where the drawing may contradict the specifications, the specifications shall prevail. This drawing and all data herein are provided as confidential materials and shall not be reproduced without written consent of the manufacturer.

NOTE 2: Chassis frame height will change due to axle characteristics, loading and tire dimensions which will affect the overall height dimension shown. Any overall height restrictions should take this into consideration and allow approximately 2-3 inches of tolerance.

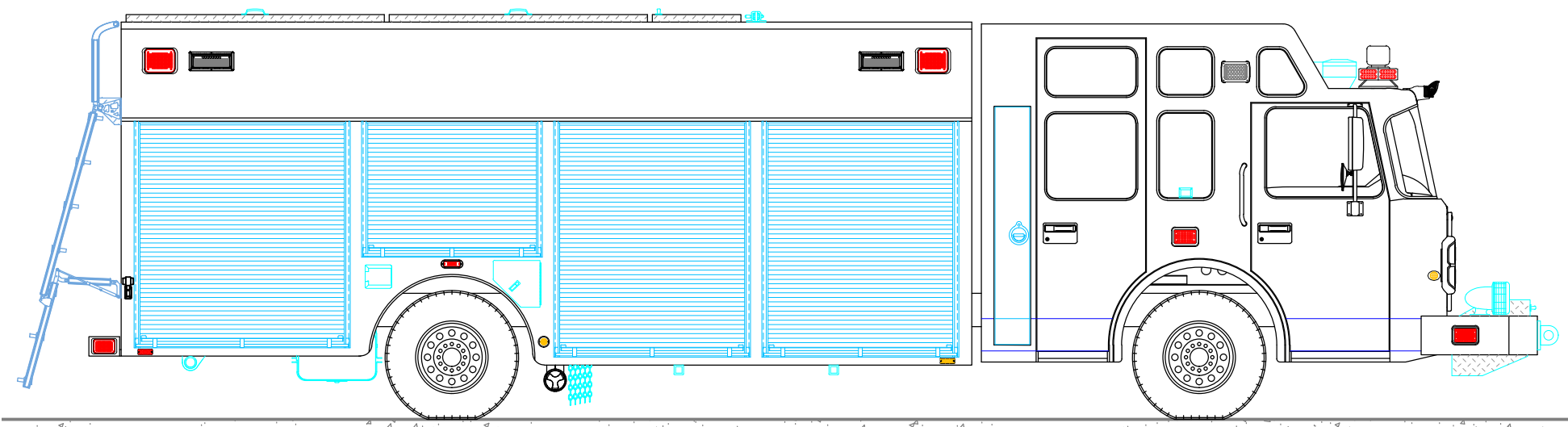
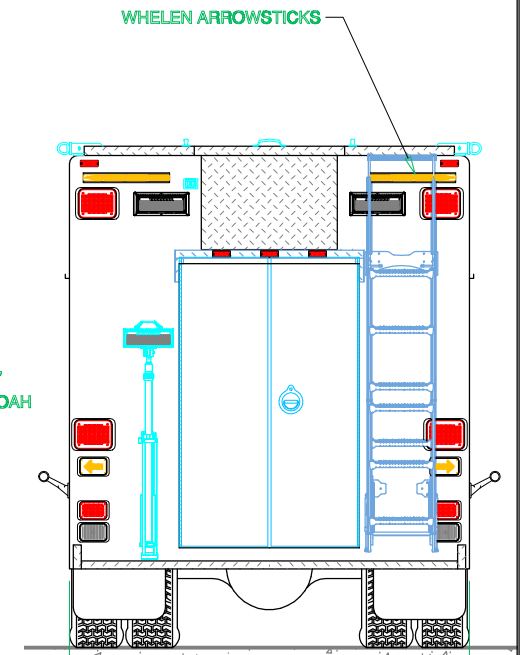
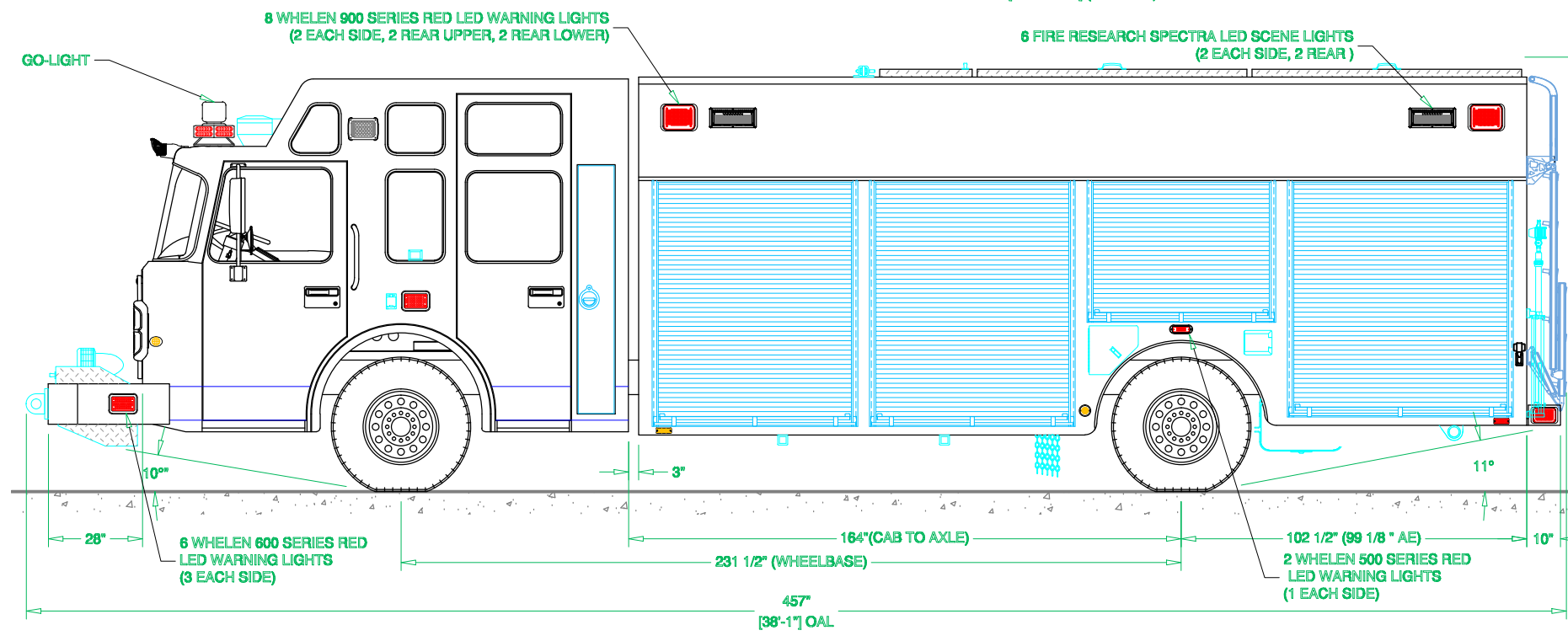
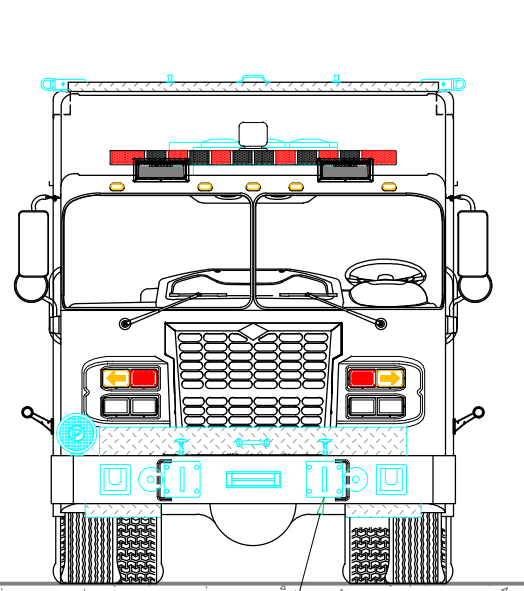
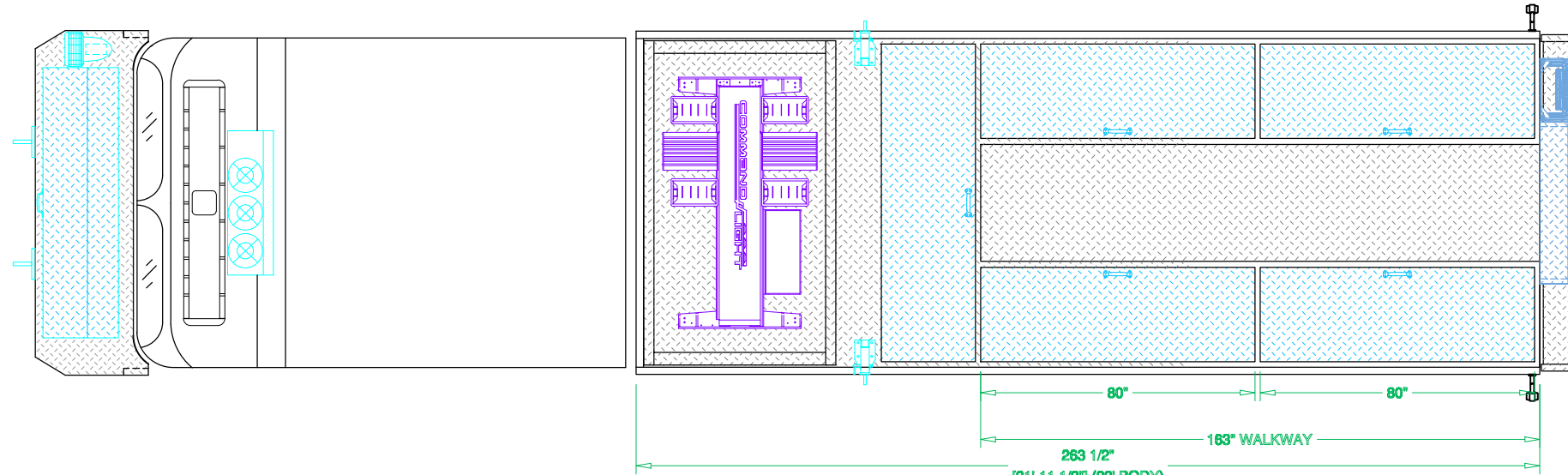

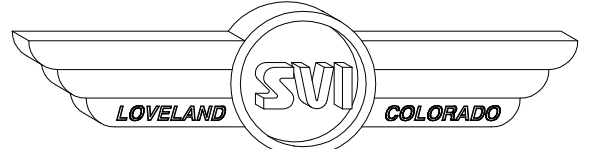

LOVELAND SVI COLORADO

SVI FIRE & RESCUE TRUCKS
3842 REDMAN DRIVE, FORT COLLINS, CO 80524 PHONE 970-297-7100, FAX 970-297-7099

LOVELAND FIRE AUTHORITY

BODY SIZE: 22' BODY	UNIT TYPE: HEAVY RESCUE
BODY MATERIAL: 3/16" ALUMINUM	TRUCK NO: SVI #000
CHASSIS TYPE: SPARTAN	WHEELBASE: SEE DWG
GLADIATOR LFD	CAB TO AXLE: SEE DWG
20" RR	OVERALL LENGTH (OAL): SEE DWG
FOUR DOOR	OVERALL WIDTH (OAW): SEE DWG
	OVERALL HEIGHT (OAH): SEE DWG

DRAWN BY: **JWG** DATE: **DECEMBER 13, 2012** SCALE: **1/4" = 1'-0"**
 DRAWING NO: **Loveland_CO_hr_PRELIM7** SHEET **1** OF **2**

PRELIMINARY DRAWING - FOR LAYOUT PURPOSES ONLY

REVISIONS			
REV	DESCRIPTION	DATE	BY

NOTE 1: Do not scale drawing. This drawing is for general truck configuration only. All items and dimensions shown are approximate and may vary with final production. The drawing may not provide illustration for all items in the specification. In all situations where the drawing may contradict the specifications, the specifications shall prevail. This drawing and all data herein are provided as confidential materials and shall not be reproduced without written consent of the manufacturer.

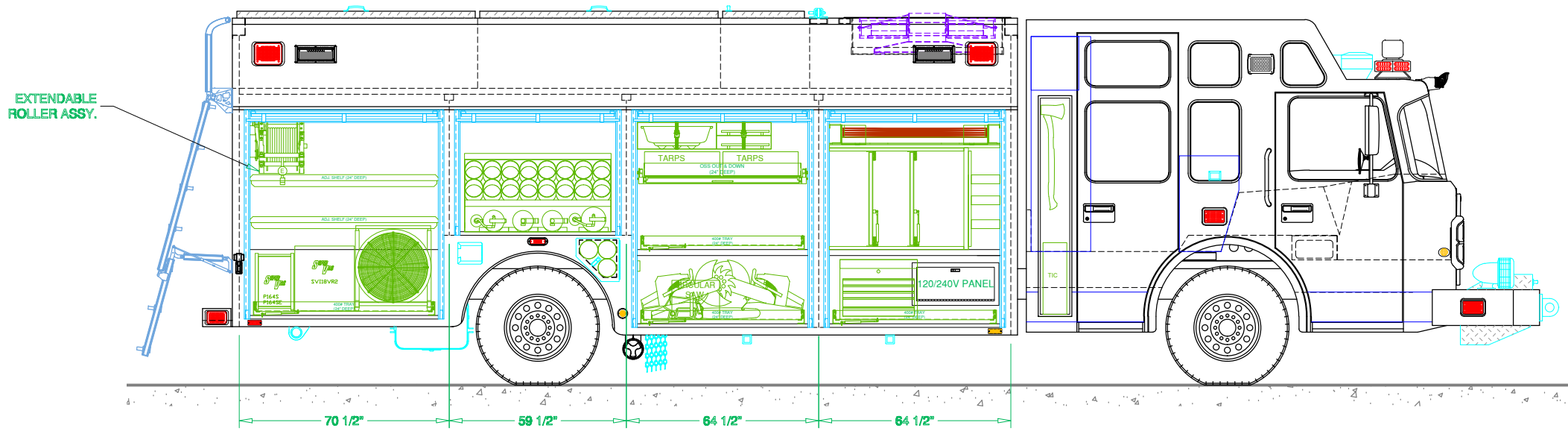
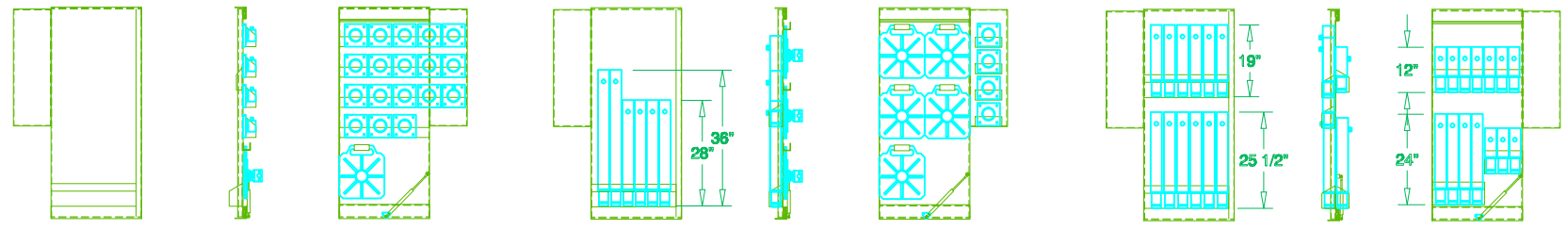
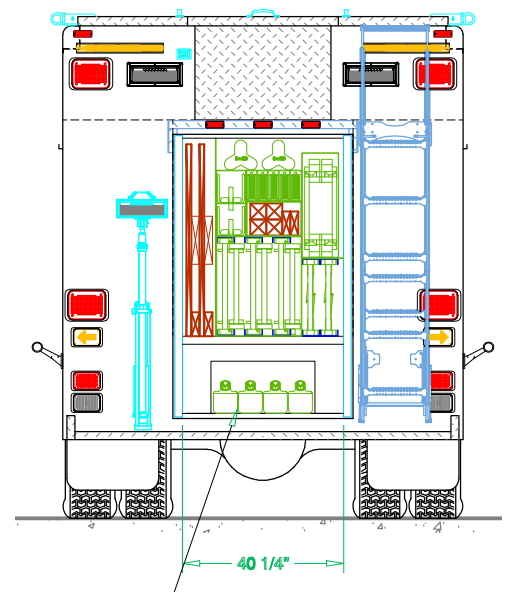
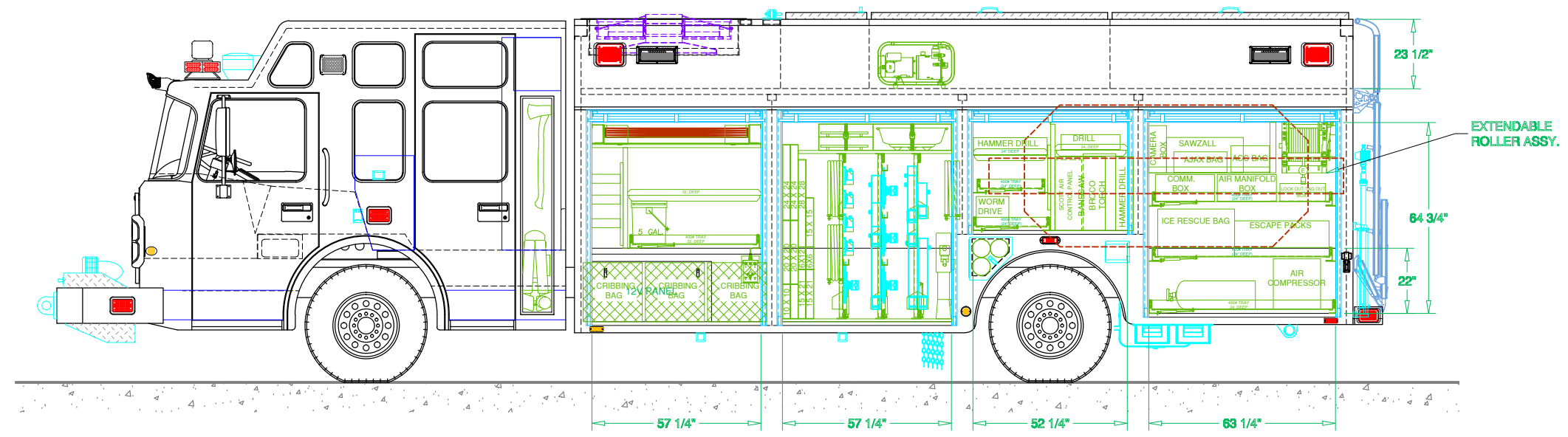
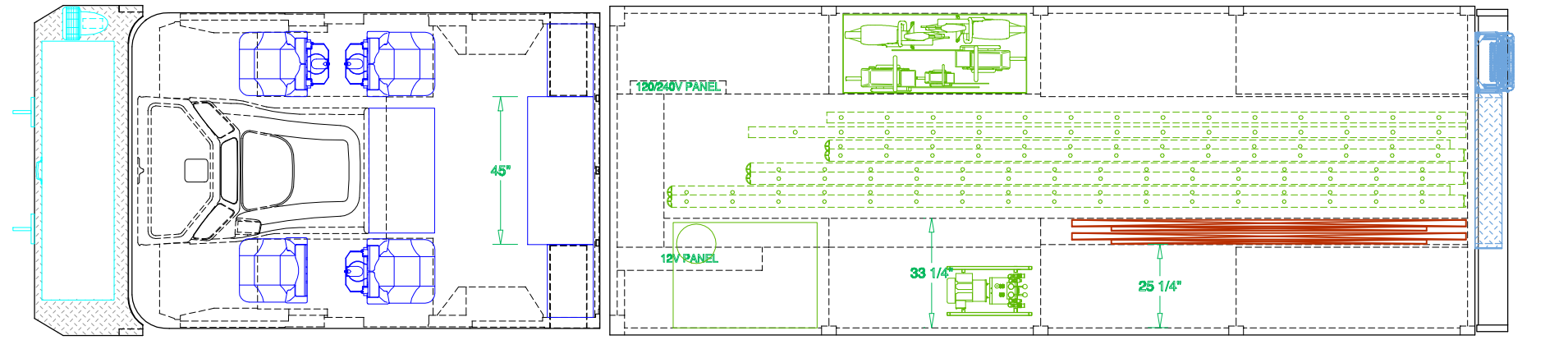



LOVELAND SVI COLORADO

SVI FIRE & RESCUE TRUCKS
3842 REDMAN DRIVE, FORT COLLINS, CO 80524 PHONE 970-297-7100, FAX 970-297-7099

LOVELAND FIRE AUTHORITY

DRAWN BY: JWG	DATE: DECEMBER 13, 2012	SCALE: 1/4" = 1'-0"
DRAWING NO: Loveland_CO_hr_PRELIM7	SHEET 2 OF 2	