

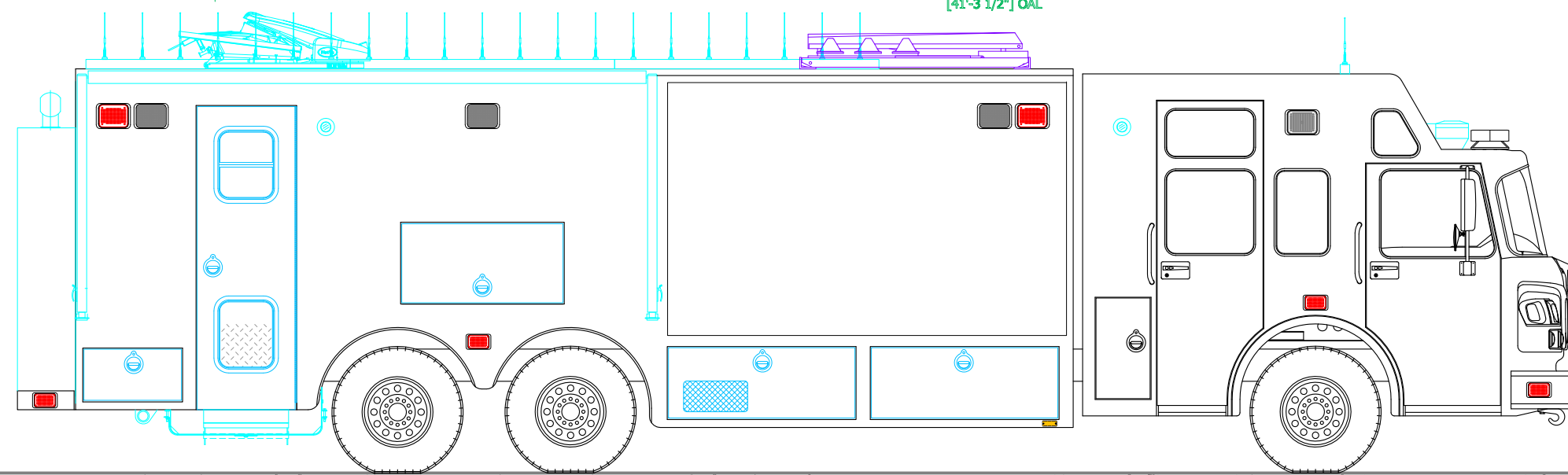
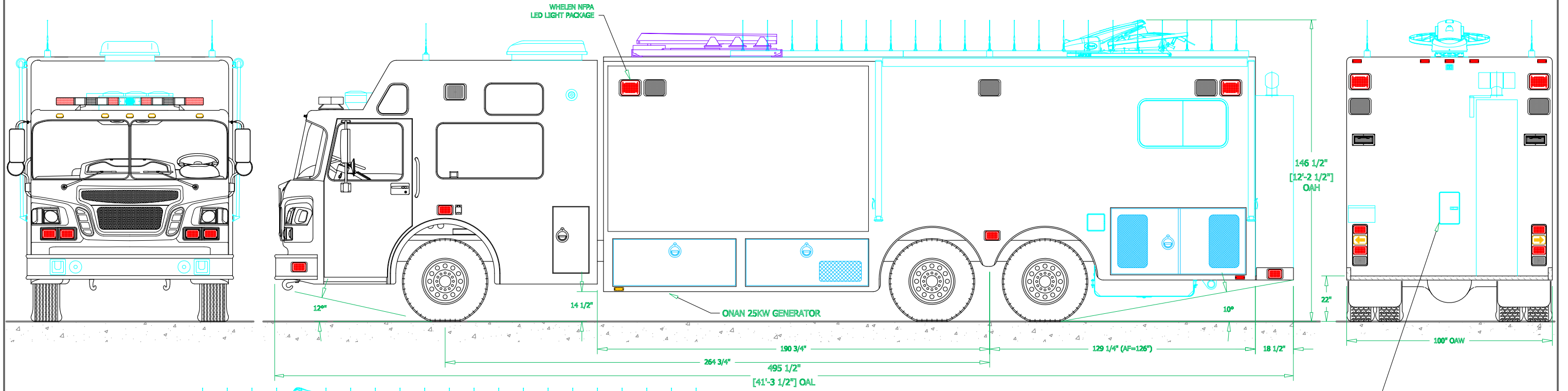
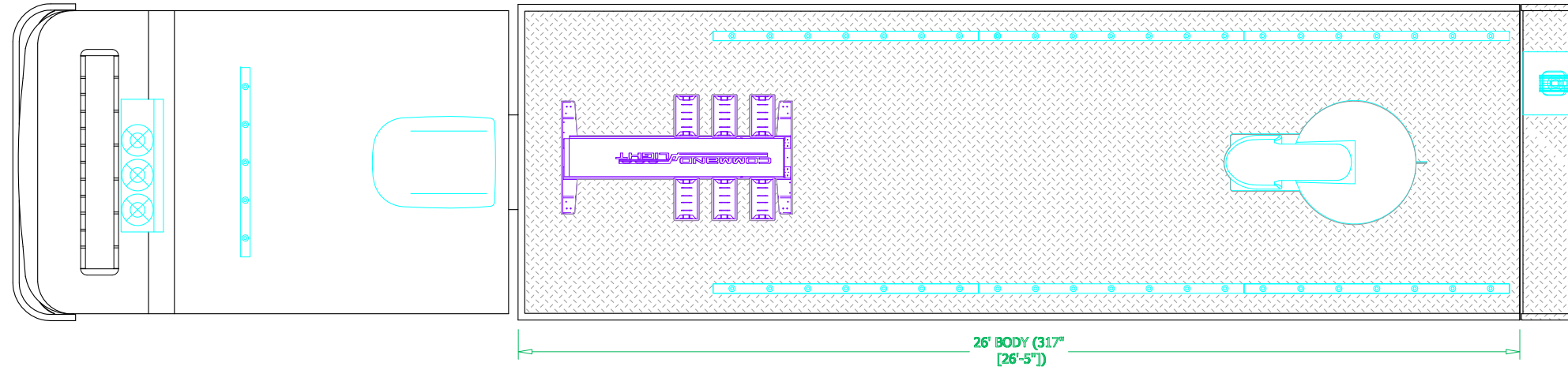

PRECONSTRUCTION PROPOSAL DRAWING, CHANGES PENDING CHANGE ORDER

REVISIONS			
REV	DESCRIPTION	DATE	BY

NOTE: Do not scale drawing. This drawing is for general truck configuration only. All items and dimensions shown are approximate and may vary with final production. The drawing may not provide illustration for all items in the specification. In all situations where the drawing may contradict the specifications, the specifications shall prevail. This drawing and all data herein are provided as confidential materials and shall not be reproduced without written consent of Super Vacuum Mfg. Co., Inc.

NOTE: Chassis frame height will change due to axle characteristics, loading and the dimensions. Changes in frame height will effect the overall height dimension shown. Any overall height restrictions should take this into consideration and allow approximately 2 inches of tolerance.





LOVELAND SVI COLORADO

SVI FIRE & RESCUE TRUCKS

1511 E. 11th STREET, LOVELAND, CO 80537 PHONE 970-667-5146, FAX 970-667-3343

SALINAS FIRE DEPARTMENT

BODY SIZE: 26' BODY	UNIT TYPE: COMMAND UNIT
BODY MATERIAL: 3/16" ALUMINUM	TRUCK NO:
CHASSIS TYPE: SPARTAN GLADIATOR EVOLUTION ELFD 3 DOOR 24" RR	WHEELBASE: 264 3/4"
	CAB TO AXLE: 190 3/4"
	OVERALL LENGTH (OAL): 498 3/4"
	OVERALL WIDTH (OAW): 100"
	OVERALL HEIGHT (OAH): 146 1/2"
DRAWN BY: JWG	DATE: NOVEMBER 17, 2008
DRAWING NO: SALINAS_CA_CMD_26_PRECON1.dwg	SCALE: 1/4" = 1' - 0"
	SHEET 1 OF 3

PRECONSTRUCTION PROPOSAL DRAWING, CHANGES PENDING CHANGE ORDER

REVISIONS			
REV	DESCRIPTION	DATE	BY

NOTE: Do not scale drawing. This drawing is for general truck configuration only. All items and dimensions shown are approximate and may vary with final production. The drawing may not provide illustration for all items in the specification. In all situations where the drawing may contradict the specifications, the specifications shall prevail. This drawing and all data herein are provided as confidential materials and shall not be reproduced without written consent of Super Vacuum Mfg. Co., Inc.

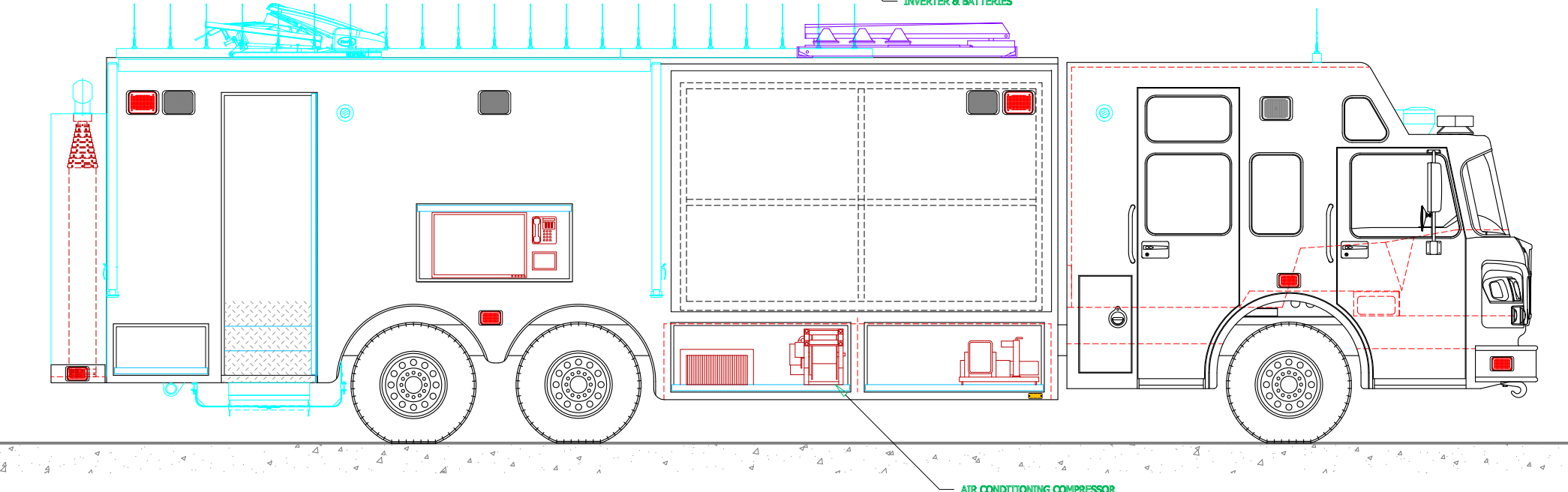
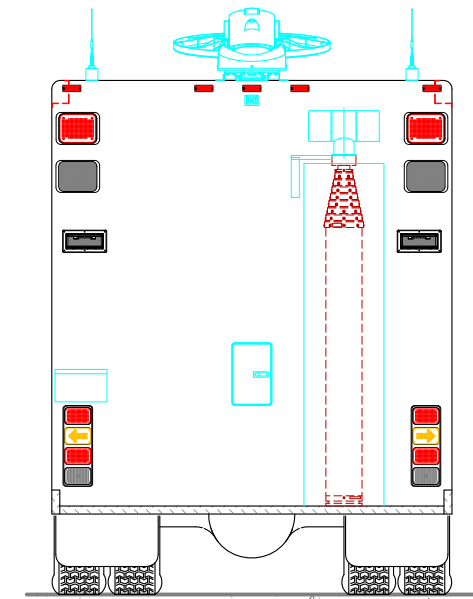
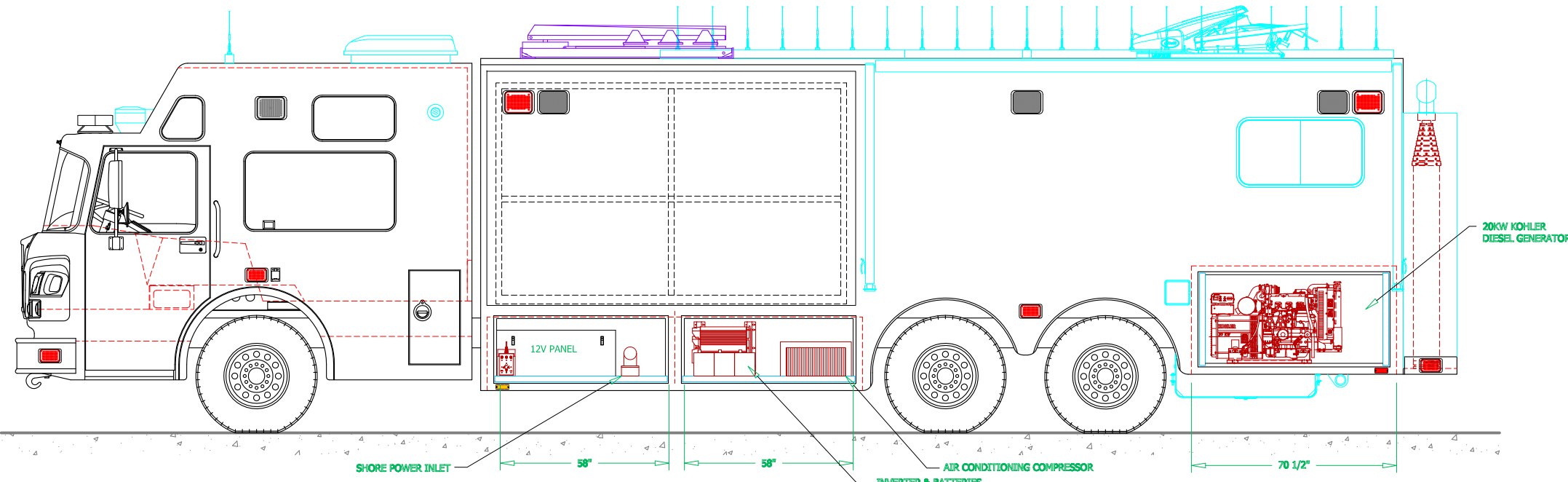
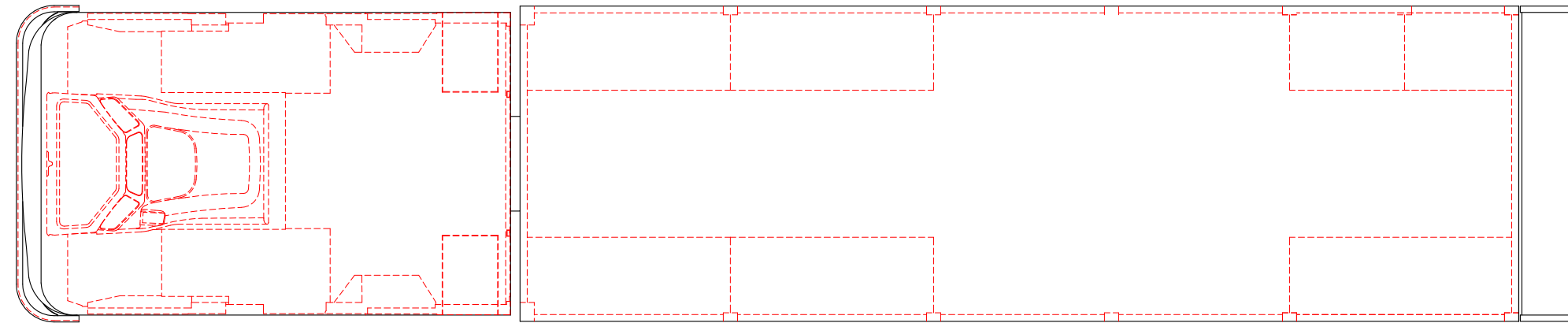

SVI FIRE & RESCUE TRUCKS
1511 E. 11th STREET, LOVELAND, CO 80537 PHONE 970-667-5146, FAX 970-667-3343

SALINAS FIRE DEPARTMENT

DRAWN BY: JWG	DATE: NOVEMBER 7, 2008	SCALE: 1/4" = 1' - 0"
DRAWING NO: SALINAS_CA_CMD_26_PRECON1.dwg	SHEET 2 OF 3	

PRECONSTRUCTION PROPOSAL DRAWING, CHANGES PENDING CHANGE ORDER

REVISIONS			
REV	DESCRIPTION	DATE	BY

NOTE: Do not scale drawing. This drawing is for general truck configuration only. All items and dimensions shown are approximate and may vary with final production. The drawing may not provide illustration for all items in the specification. In all situations where the drawing may contradict the specifications, the specifications shall prevail. This drawing and all data herein are provided as confidential materials and shall not be reproduced without written consent of Super Vacuum Mfg. Co., Inc.

PLAN VIEW
CROSS-SECTION

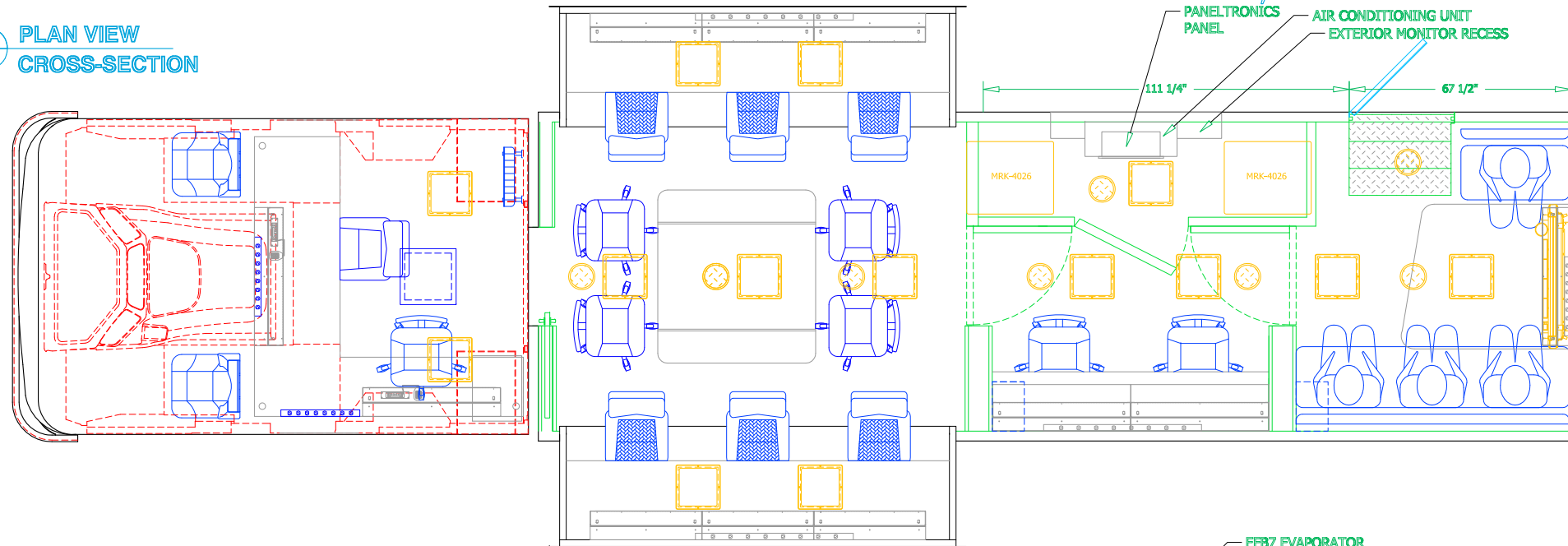

CURBSIDE INTERIOR
CROSS-SECTION

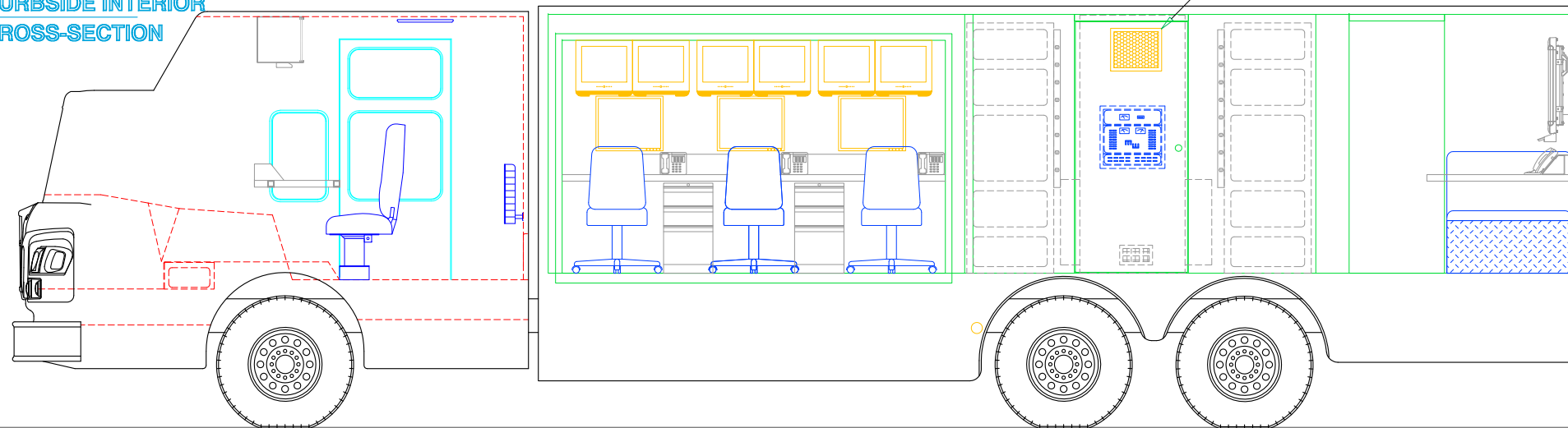

REAR VIEW
CROSS-SECTION

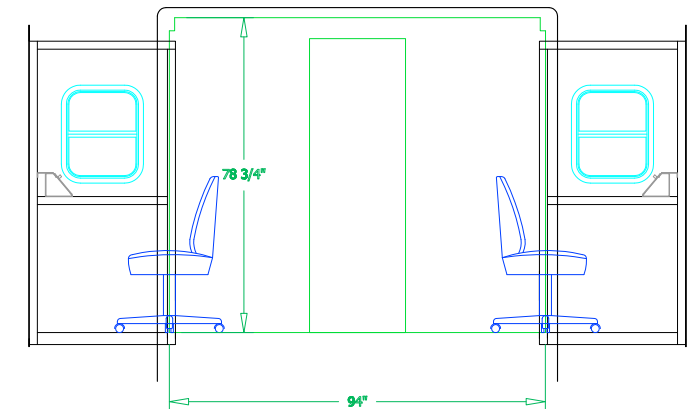

STREETSIDE INTERIOR
CROSS-SECTION

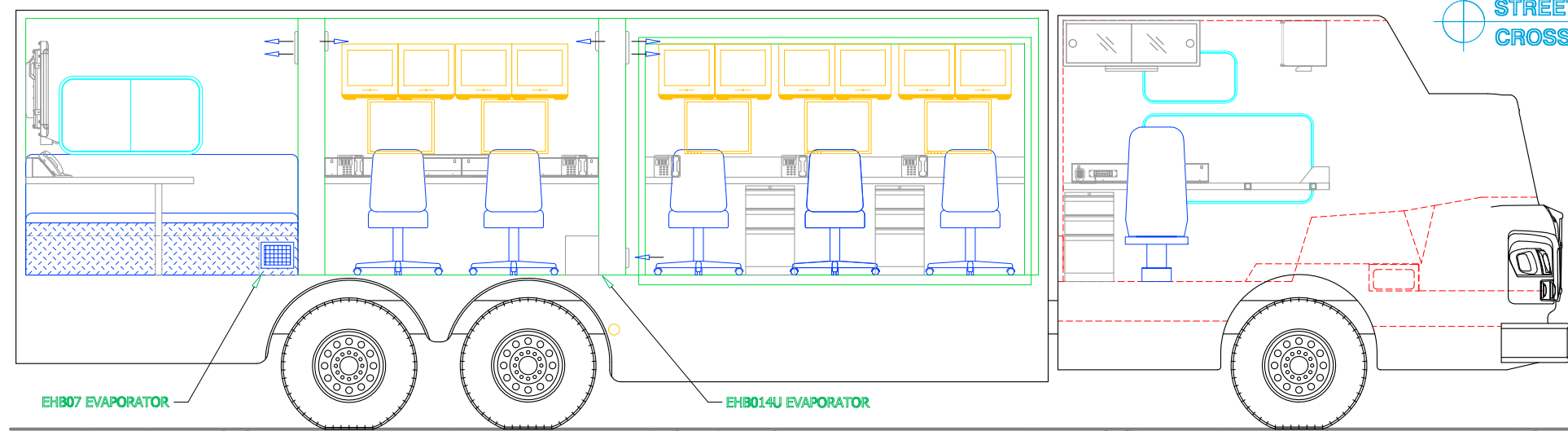

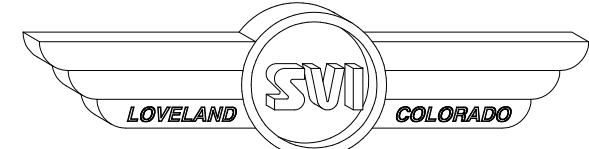

LOVELAND SVI COLORADO

SVI FIRE & RESCUE TRUCKS
1511 E. 11th STREET, LOVELAND, CO 80537 PHONE 970-667-5146, FAX 970-667-3343

SALINAS FIRE DEPARTMENT

DRAWN BY: JWG	DATE: NOVEMBER 7, 2008	SCALE: 1/4" = 1' - 0"
DRAWING NO: SALINAS_CA_CMD_26_PRECON1.dwg	SHEET 3 OF 3	