

PRECONSTRUCTION PROPOSAL DRAWING, CHANGES PENDING CHANGE ORDER

REVISIONS			
REV	DESCRIPTION	DATE	BY

NOTE 1: Do not scale drawing. This drawing is for general truck configuration only. All items and dimensions shown are approximate and may vary with final production. The drawing may not provide illustration for all items in the specification. In all situations where the drawing may contradict the specifications, the specifications shall prevail. This drawing and all data herein are provided as confidential materials and shall not be reproduced without written consent of the manufacturer.

NOTE 2: Chassis frame height will change due to axle characteristics, loading and the dimensions which will effect the overall height dimension shown. Any overall height restrictions should take this into consideration and allow approximately 2-3 inches of tolerance.

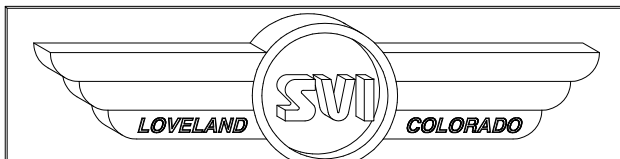
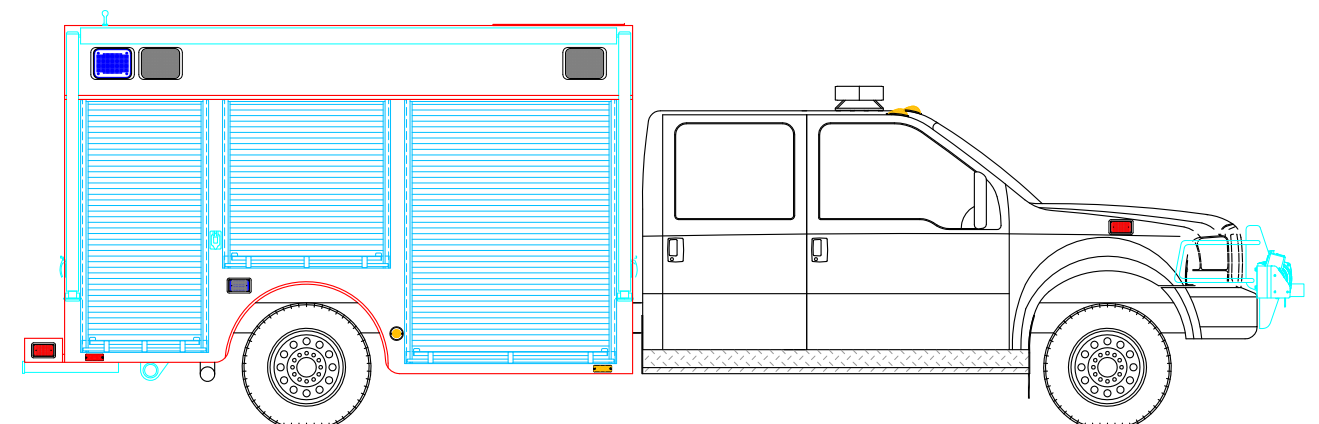
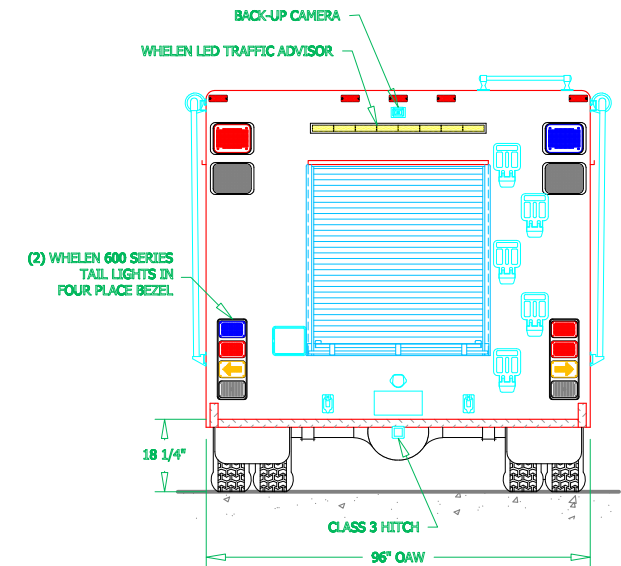
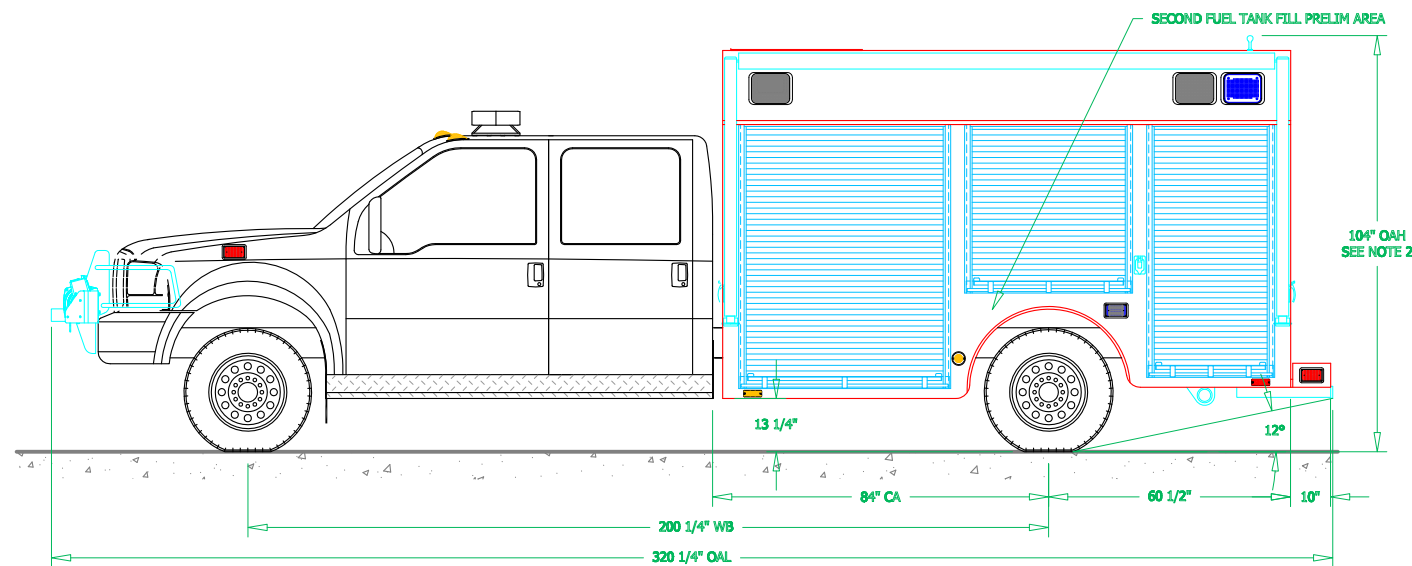
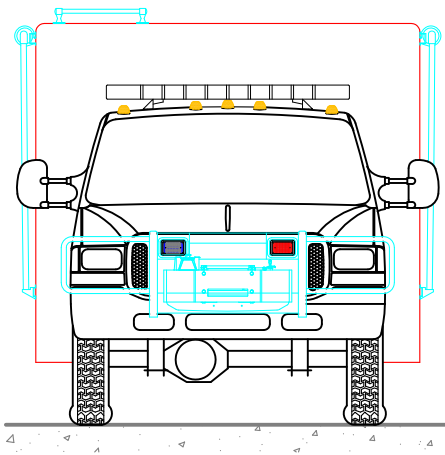
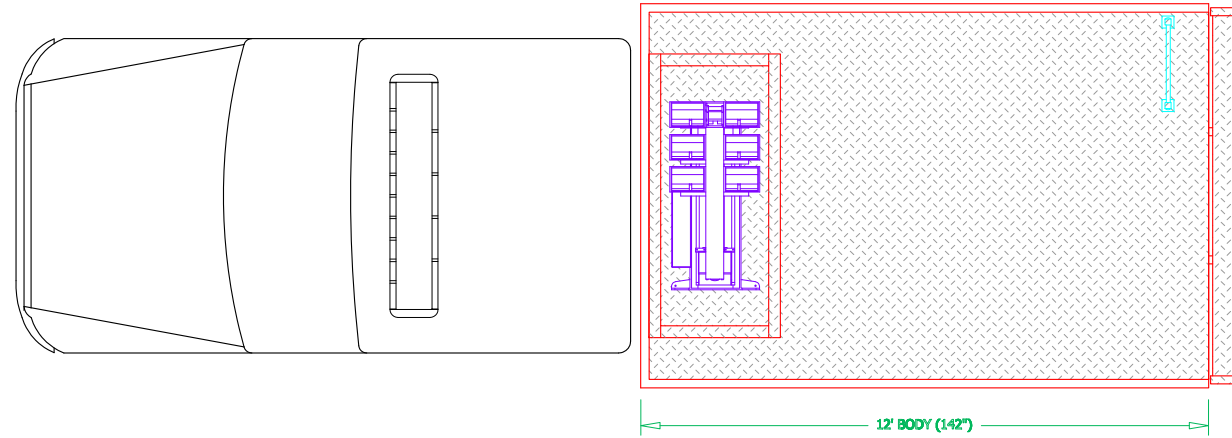

SVI FIRE & RESCUE TRUCKS
1511 E. 11th STREET, LOVELAND, CO 80537 PHONE 970-667-5146, FAX 970-667-3343

COLORADO BUREAU OF INVESTIGATION

BODY SIZE: 12' BODY	UNIT TYPE: LIGHT RESCUE
BODY MATERIAL: 1/8" ALUMINUM	TRUCK NO: 631
CHASSIS TYPE: FORD	WHEELBASE: 200 1/4"
F 550	CAB TO AXLE: 84"
4 DOOR	OVERALL LENGTH (OAL): 325 3/4"
4 X 4	OVERALL WIDTH (OAW): 96"
	OVERALL HEIGHT (OAH): 90 1/2"

PRECONSTRUCTION PROPOSAL DRAWING, CHANGES PENDING CHANGE ORDER

REVISIONS			
REV	DESCRIPTION	DATE	BY

NOTE 1: Do not scale drawing. This drawing is for general truck configuration only. All items and dimensions shown are approximate and may vary with final production. The drawing may not provide illustration for all items in the specification. In all situations where the drawing may contradict the specifications, the specifications shall prevail. This drawing and all data herein are provided as confidential materials and shall not be reproduced without written consent of the manufacturer.

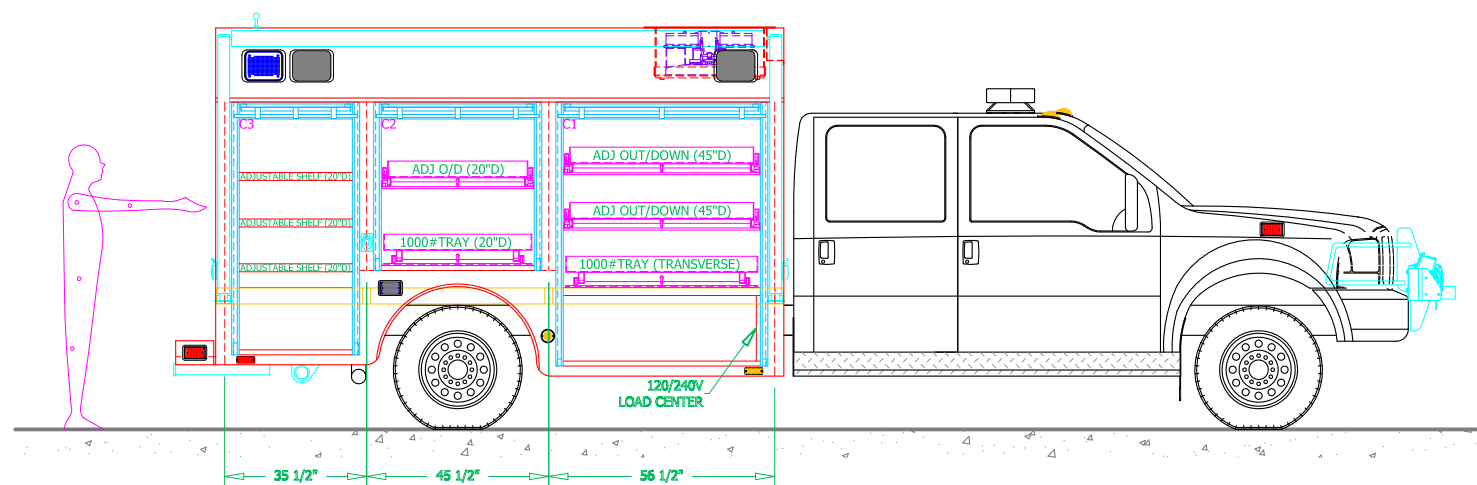
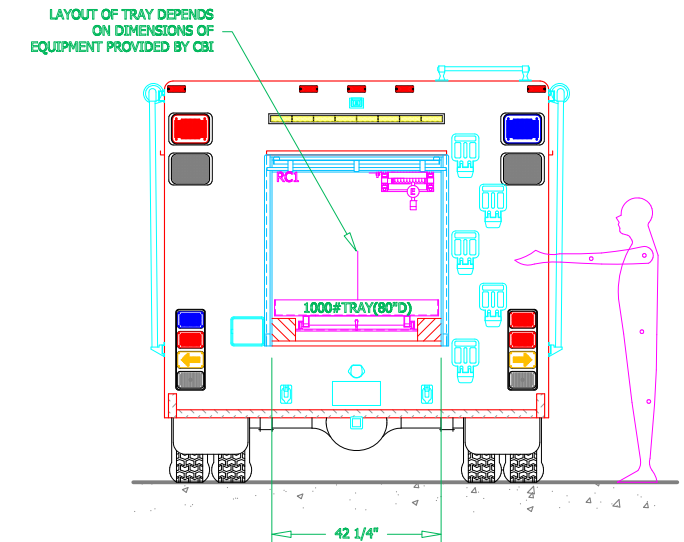
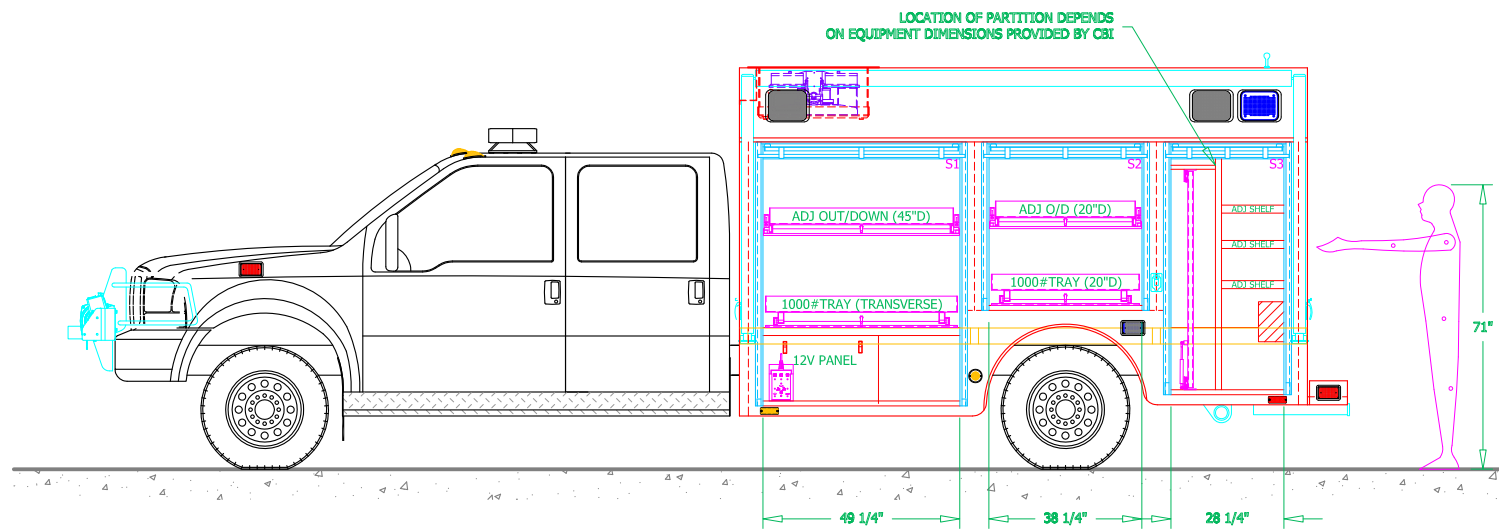
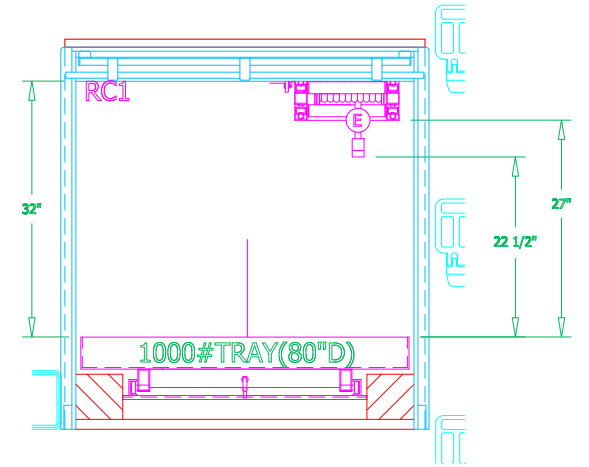
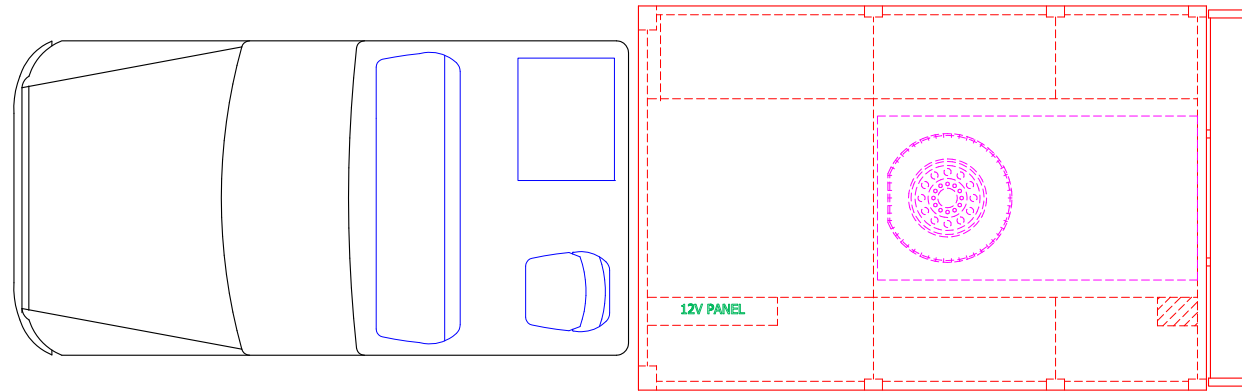

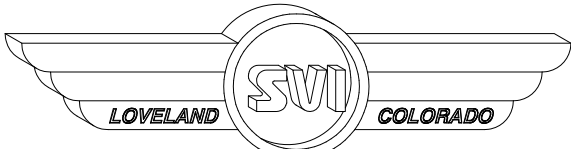

LOVELAND SVI COLORADO

SVI FIRE & RESCUE TRUCKS
1511 E. 11th STREET, LOVELAND, CO 80537 PHONE 970-667-5146, FAX 970-667-3343

COLORADO BUREAU OF INVESTIGATION

DRAWN BY: NMT	DATE: February 12, 2007	SCALE: 1/4" = 1' - 0"
DRAWING NO: CBI_CO_LR_631_REV_B.dwg	SHEET 2 OF 2	