

REVISIONS			
REV	DESCRIPTION	DATE	BY

NOTE: Do not scale drawing. This drawing is for general truck configuration only. All items and dimensions shown are approximate and may vary with final production. The drawing may not provide illustration for all items in the specifications, the specifications shall prevail. This drawing and all data herein are provided as confidential materials and shall not be reproduced without written consent of Super Vacuum Mfg. Co., Inc.

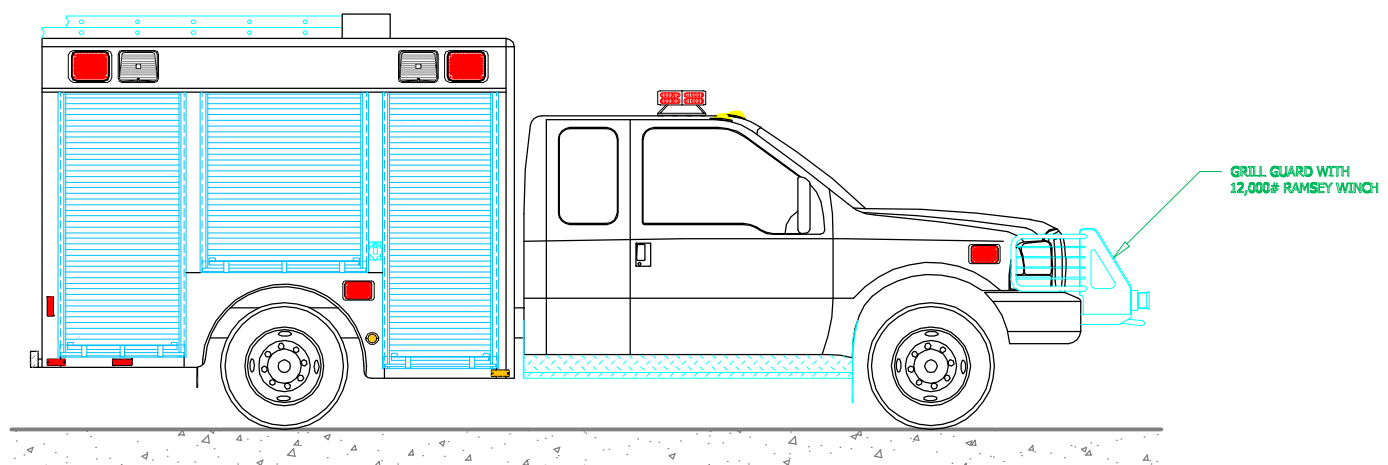
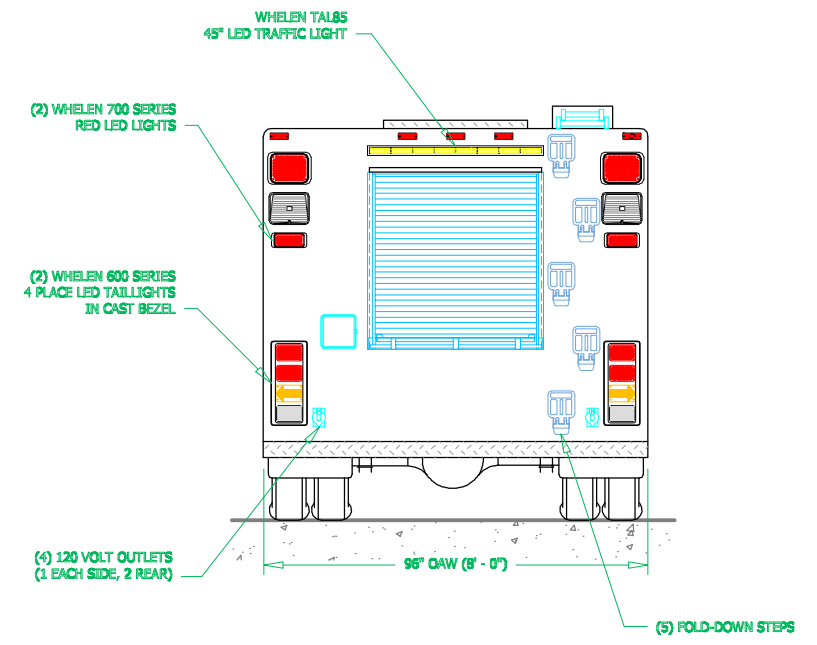
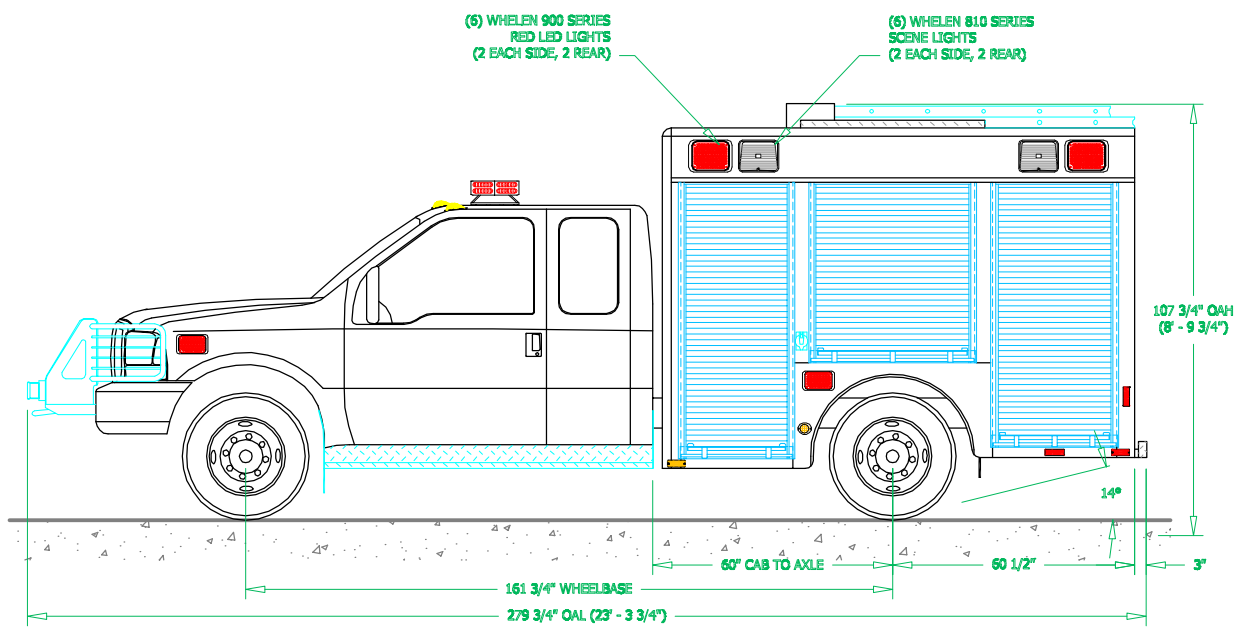
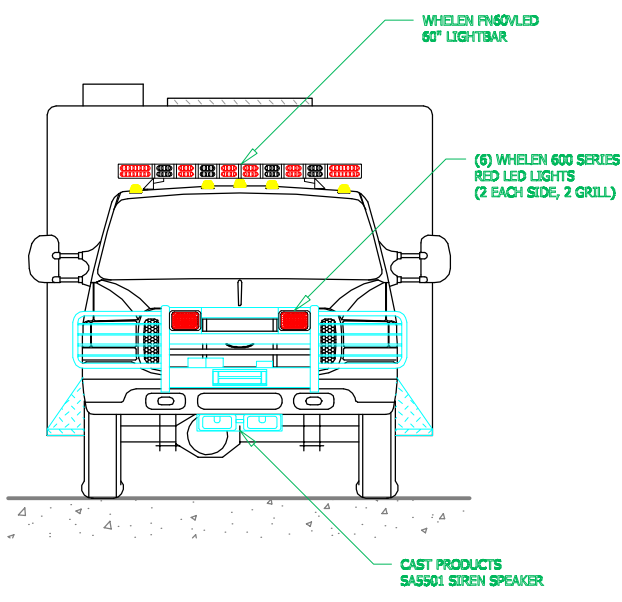
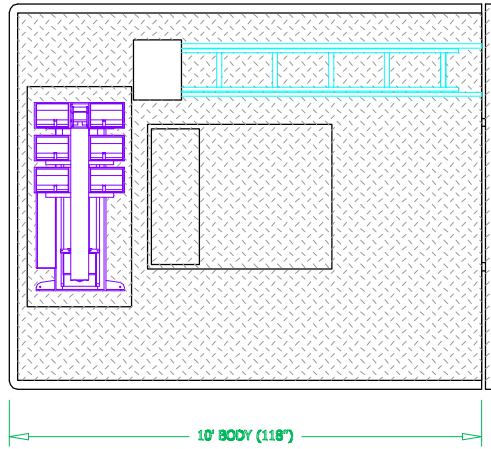

SVI FIRE & RESCUE TRUCKS
1511 E. 11th STREET, LOVELAND, CO 80537 PHONE 970-667-5146, FAX 970-667-3343

**ELIZABETH
FIRE DEPARTMENT**

BODY SIZE: 10' BODY	UNIT TYPE: LIGHT RESCUE
BODY MATERIAL: 3/16" ALUMINUM	TRUCK NO: 511
CHASSIS TYPE: FORD F550 4X4 2 DOOR EXTENDED CAB	WHEELBASE: 161 3/4"
	CAB TO AXLE: 60"
	OVERALL LENGTH (OAL): 23' - 3 3/4"
	OVERALL WIDTH (OAW): 8' - 0"
	OVERALL HEIGHT (OAH): 8' - 9 3/4"

DRAWN BY: DRH DATE: MARCH 31, 2003 SCALE: 1/4" = 1' - 0"
DRAWING NO: ELIZABETH_CO_LR_10_511.DWG SHEET 1 OF 2

NOTE: Do not scale drawing. This drawing is for general truck configuration only. All items and dimensions shown are approximate and may vary with final production. The drawing may not provide illustration for all items in the specification. In all situations where the drawing may contradict the specifications, the specifications shall prevail. This drawing and all data herein are provided as confidential materials and shall not be reproduced without written consent of Super Vacuum Mfg. Co., Inc.

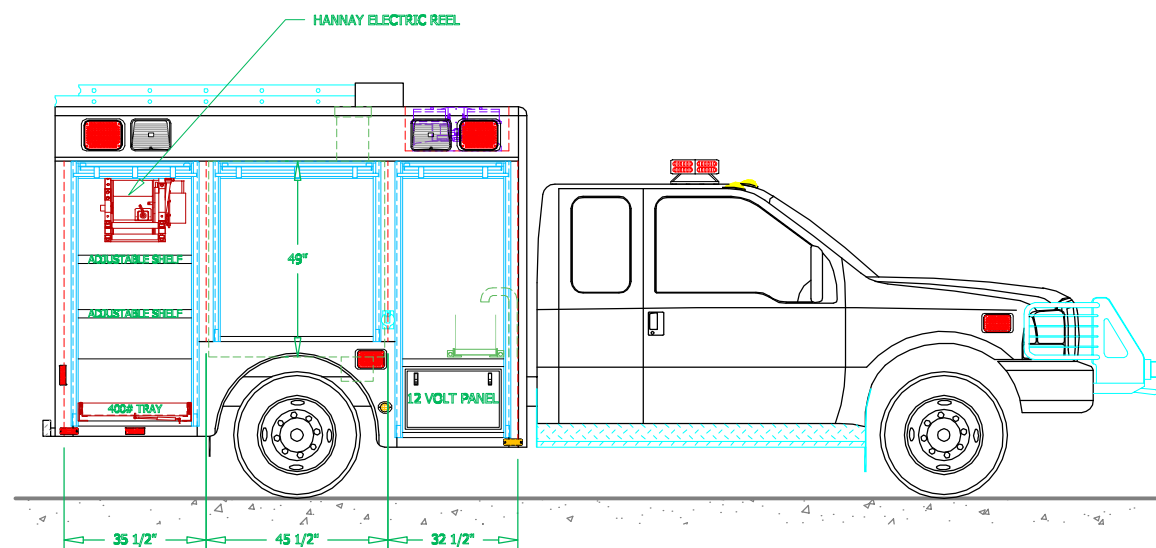
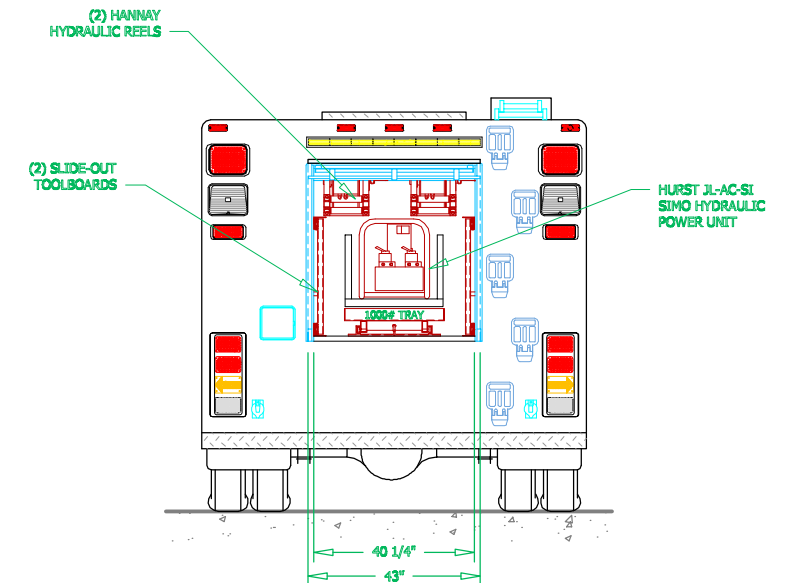
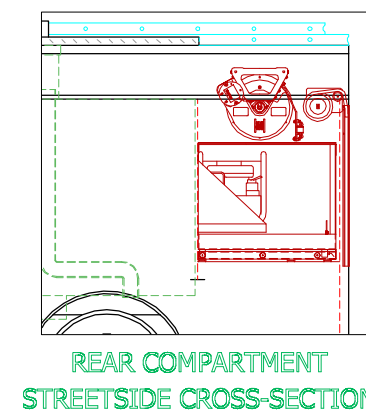
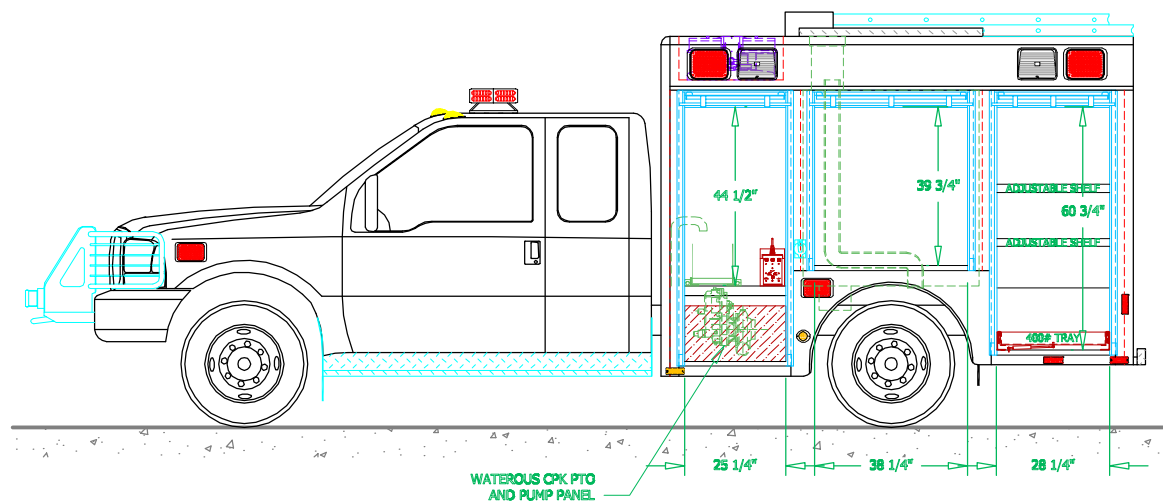
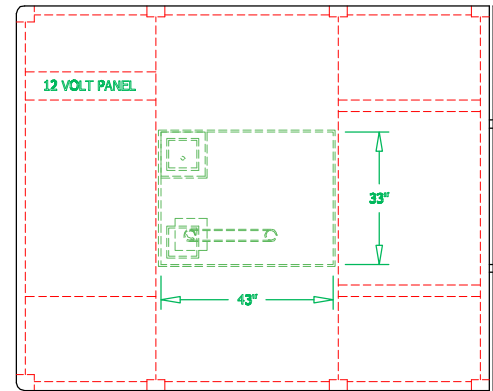

SVI FIRE & RESCUE TRUCKS
1511 E. 11th STREET, LOVELAND, CO 80537 PHONE 970-667-5146, FAX 970-667-3343

**ELIZABETH
FIRE DEPARTMENT**

DRAWN BY: DRH	DATE: MARCH 31, 2003	SCALE: 1/4" = 1' - 0"
DRAWING NO: ELIZABETH_CO_LR_10_511.DWG	SHEET 2 OF 2	