

PRELIMINARY DRAWING - FOR LAYOUT PURPOSES ONLY

REVISIONS			
REV	DESCRIPTION	DATE	BY

NOTE 1: Do not scale drawing. This drawing is for general truck configuration only. All items and dimensions shown are approximate and may vary with final production. The drawing may not provide illustration for all items in the specification. In all situations where the drawing may contradict the specifications, the specifications shall prevail. This drawing and all data herein are provided as confidential materials and shall not be reproduced without written consent of the manufacturer.

NOTE 2: Chassis frame height will change due to axle characteristics, loading and tire dimensions which will affect the overall height dimension shown. Any overall height restrictions should take this into consideration and allow approximately 2-3 inches of tolerance.

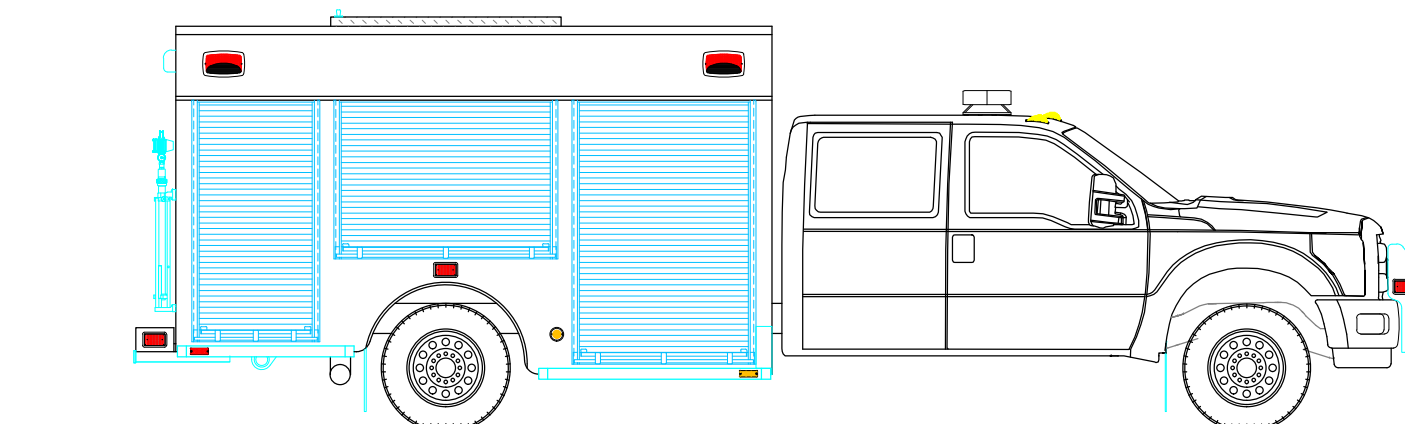
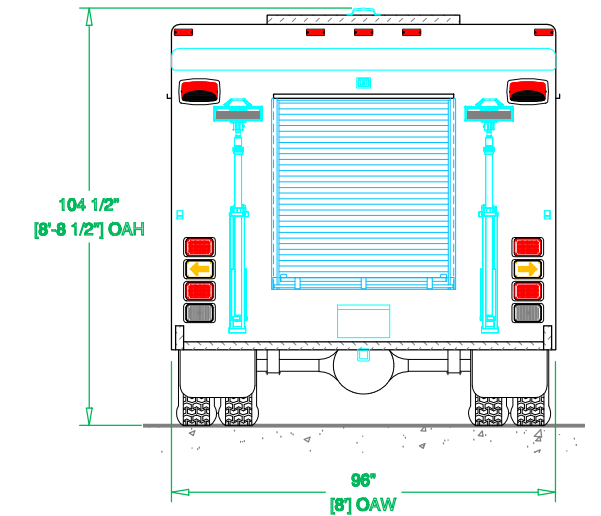
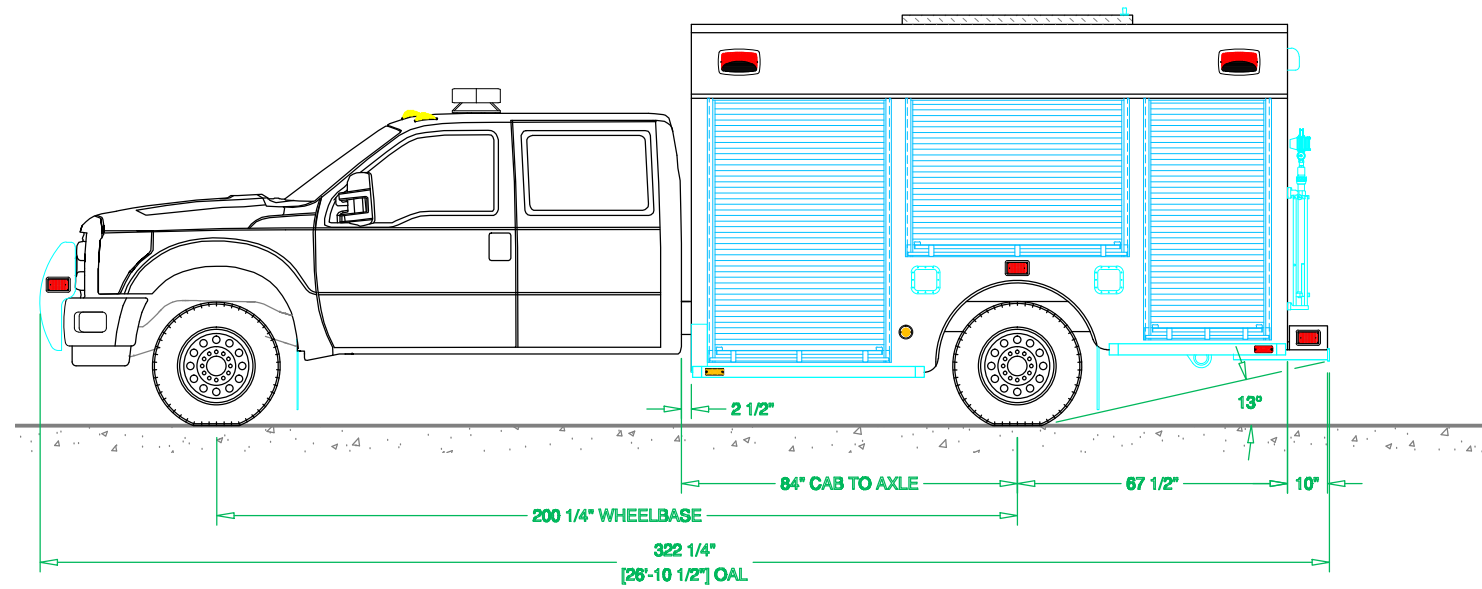
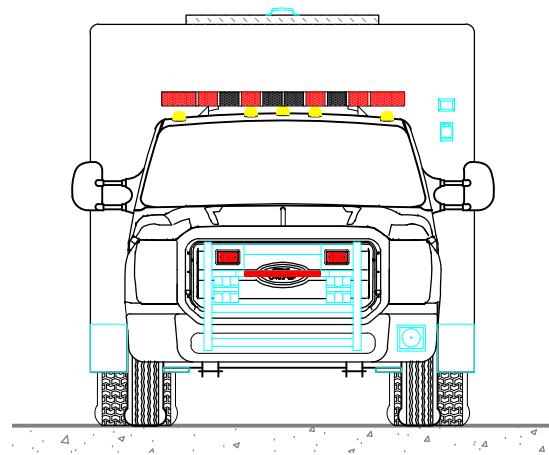
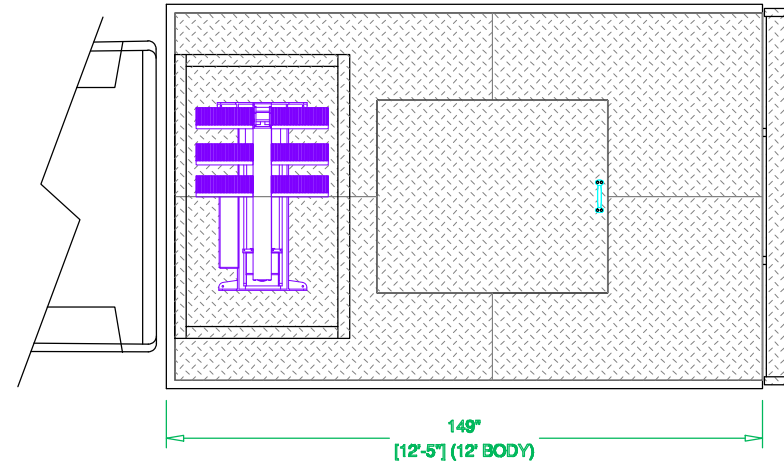

SVI FIRE & RESCUE TRUCKS
3842 REDMAN DRIVE, FORT COLLINS, CO 80524 PHONE 970-297-7100, FAX 970-297-7099

**DALTON
FIRE DEPARTMENT**

BODY SIZE: 12' BODY	UNIT TYPE: LIGHT RESCUE
BODY MATERIAL: 3/16" ALUMINUM	TRUCK NO: SVI #000
CHASSIS TYPE: FORD F550	WHEELBASE: SEE DWG
	CAB TO AXLE: SEE DWG
	OVERALL LENGTH (OAL): SEE DWG
	OVERALL WIDTH (OAW): SEE DWG
FOUR DOOR	OVERALL HEIGHT (OAH): SEE DWG
DRAWN BY: HJR	DATE: June 2, 2016
DRAWING NO: Dalton_GA_LR_PreCont1	SCALE: 1/4" = 1'-0"

SHEET 1 OF 2

PRELIMINARY DRAWING - FOR LAYOUT PURPOSES ONLY

REVISIONS			
REV	DESCRIPTION	DATE	BY

NOTE 1: Do not scale drawing. This drawing is for general truck configuration only. All items and dimensions shown are approximate and may vary with final production. The drawing may not provide illustration for all items in the specification. In all situations where the drawing may contradict the specifications, the specifications shall prevail. This drawing and all data herein are provided as confidential materials and shall not be reproduced without written consent of the manufacturer.

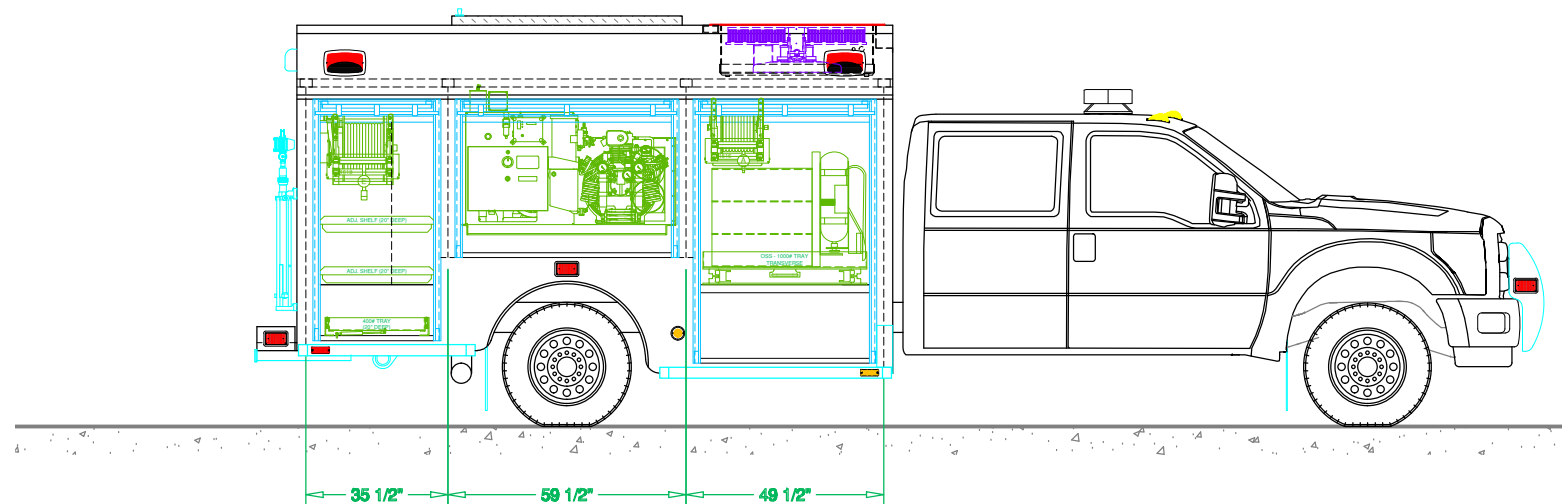
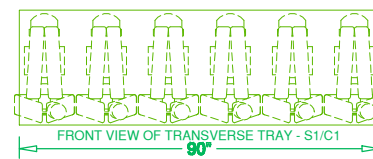
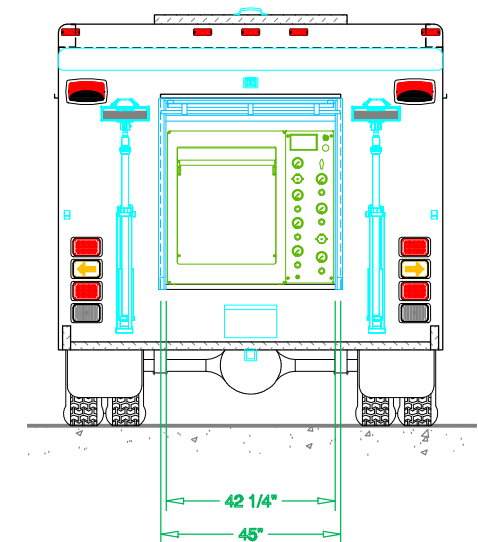
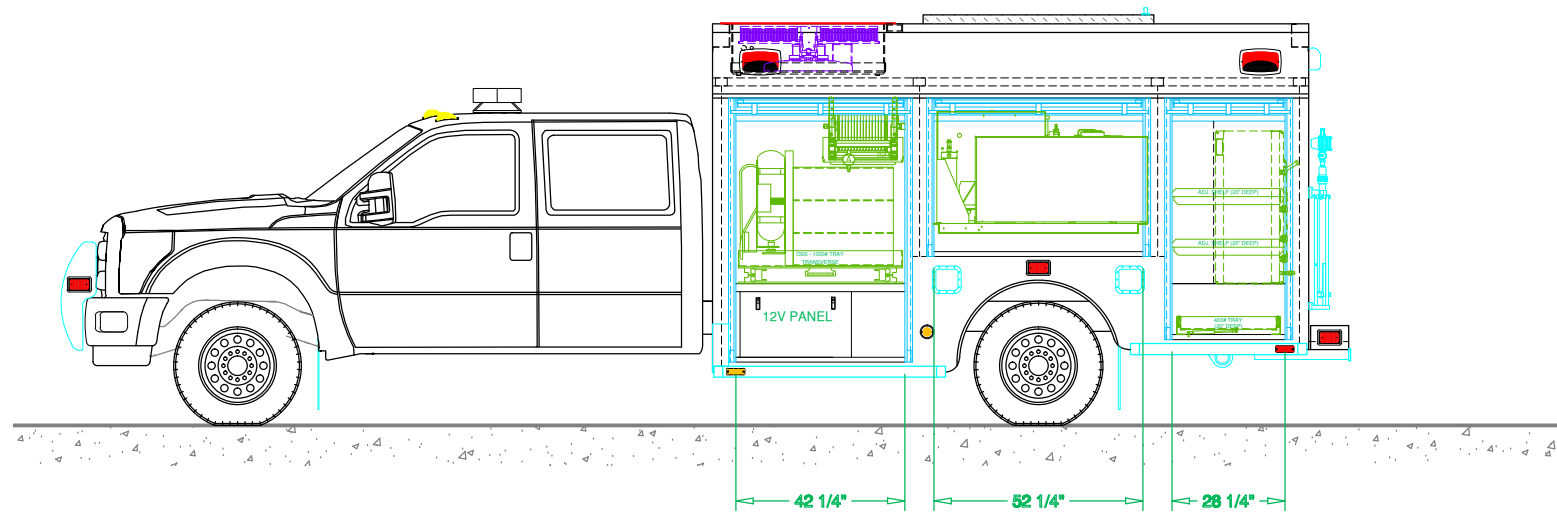
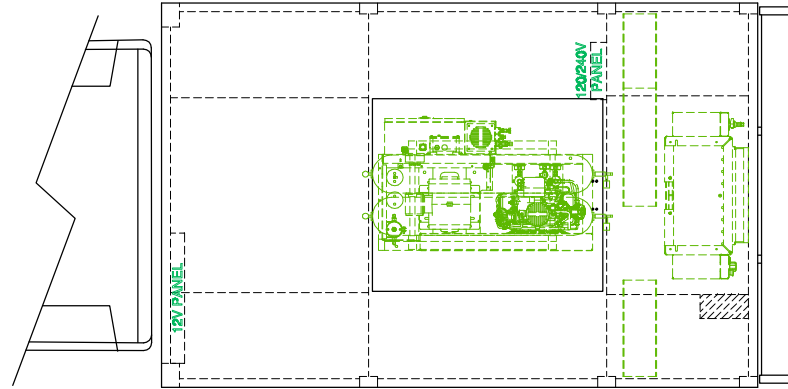

SVI FIRE & RESCUE TRUCKS
3842 REDMAN DRIVE, FORT COLLINS, CO 80524 PHONE 970-297-7100, FAX 970-297-7099

DALTON
FIRE DEPARTMENT