

PRELIMINARY DRAWING - FOR LAYOUT PURPOSES ONLY

20# PROPANE BOTTLE STORAGE

REVISIONS			
REV	DESCRIPTION	DATE	BY

NOTE 1: Do not scale drawing. This drawing is for general truck configuration only. All items and dimensions shown are approximate and may vary with final production. The drawing may not provide illustration for all items in the specification. In all situations where the drawing may contradict the specifications, the specifications shall prevail. This drawing and all data herein are provided as confidential materials and shall not be reproduced without written consent of the manufacturer.

NOTE 2: Chassis frame height will change due to axle characteristics, loading and tire dimensions which will effect the overall height dimension shown. Any overall height restrictions should take this into consideration and allow approximately 2-3 inches of tolerance.

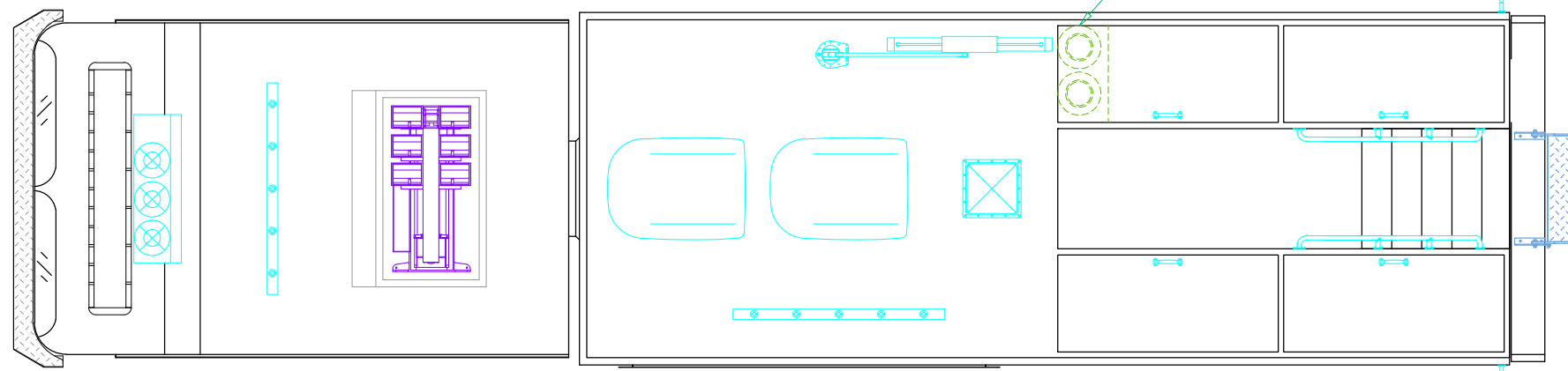

263 1/2"
[21'-11 1/2"] (22' BODY)

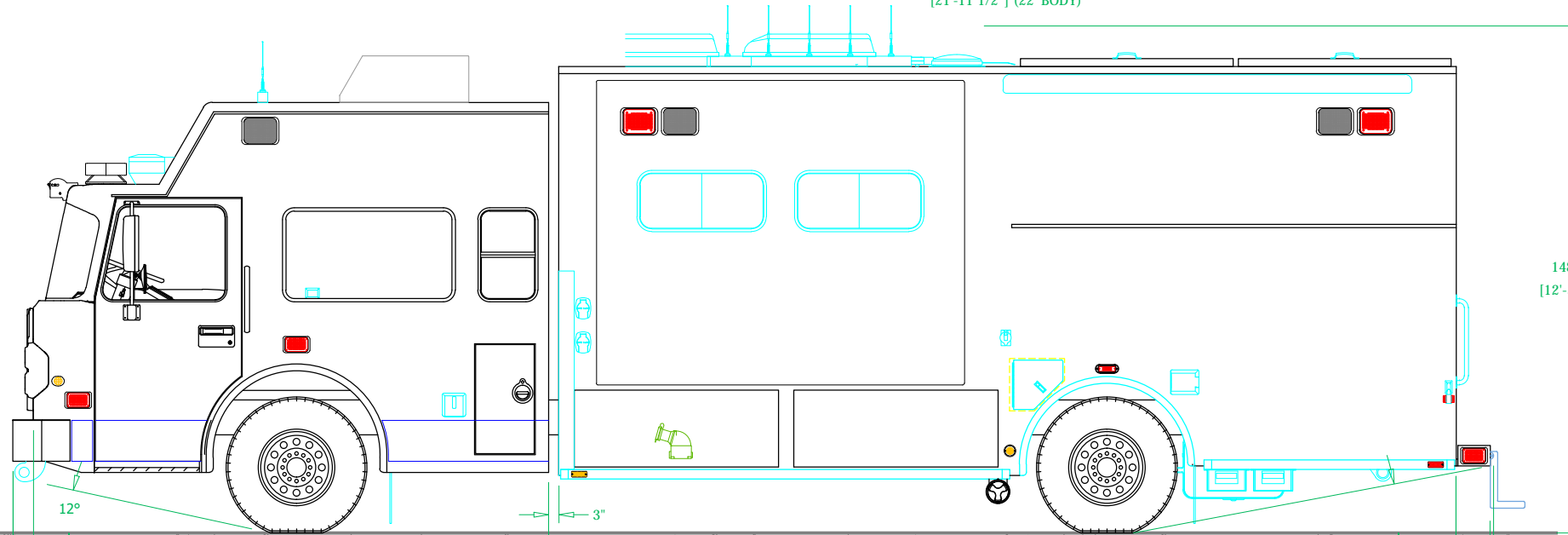
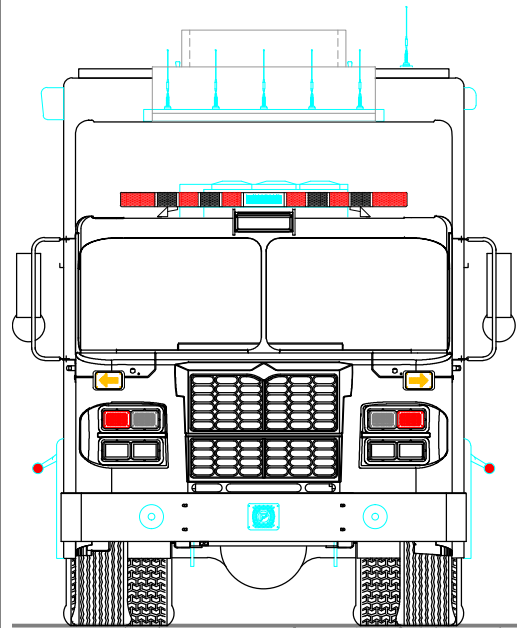

148 3/4"
[12'-5"] OAH

6" 12° 3" 164" CAB TO AXLE 102 1/2" 10" 238" WHEELBASE 434 3/4" [36'-3"] OAL

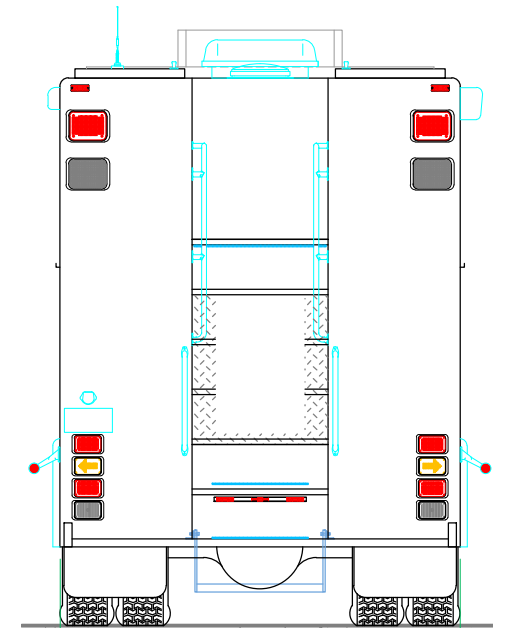

100"
[8'-4"] OAW

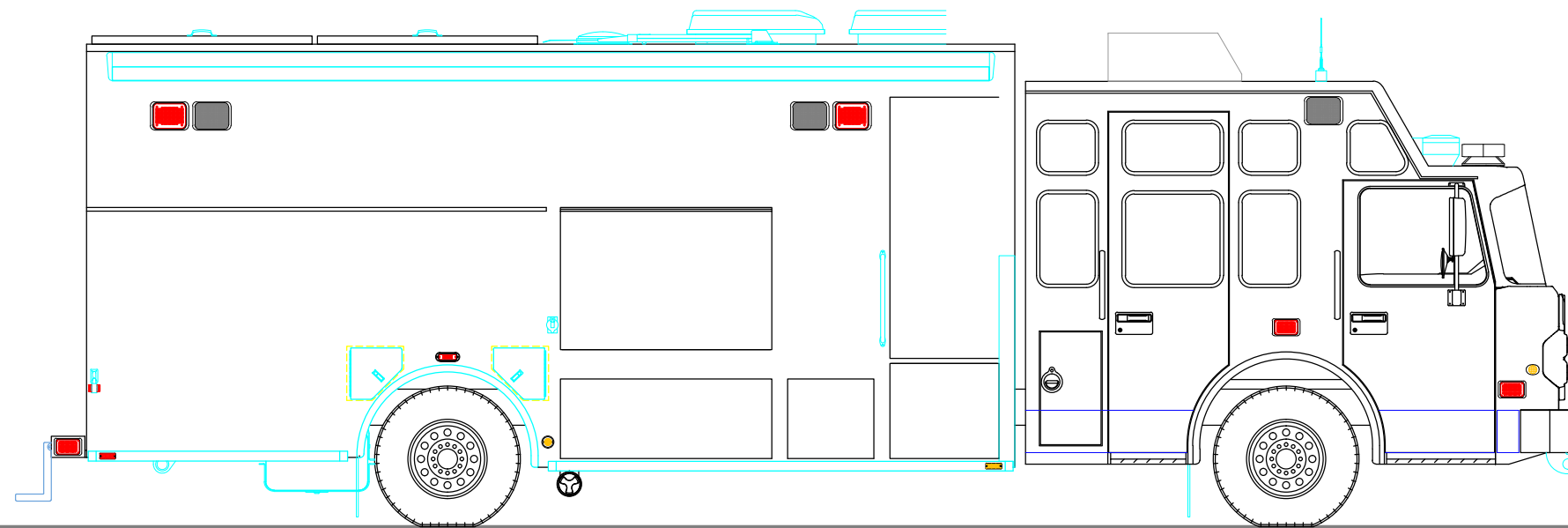

SVI FIRE & RESCUE TRUCKS
3842 REDMAN DRIVE, FORT COLLINS, CO 80524 PHONE 970-297-7100, FAX 970-297-7099

BURLINGTON
FIRE DEPARTMENT

BODY SIZE: 22' BODY	UNIT TYPE: COMMAND
BODY MATERIAL: 3/16" ALUMINUM	TRUCK NO: SVI #xxx
CHASSIS TYPE: SPARTAN	WHEELBASE: SEE DWG
METRO STAR ELFD	CAB TO AXLE: SEE DWG
24" RR	OVERALL LENGTH (OAL): SEE DWG
THREE DOOR	OVERALL WIDTH (OAW): SEE DWG
	OVERALL HEIGHT (OAH): SEE DWG

DRAWN BY: HJR DATE: June 27, 2016 SCALE: 1/4" = 1'-0"
DRAWING NO: Burlington_ON_wi_PreCont SHEET 1 OF 3

PRELIMINARY DRAWING - FOR LAYOUT PURPOSES ONLY

REVISIONS			
REV	DESCRIPTION	DATE	BY

NOTE 1: Do not scale drawing. This drawing is for general truck configuration only. All items and dimensions shown are approximate and may vary with final production. The drawing may not provide illustration for all items in the specification. In all situations where the drawing may contradict the specifications, the specifications shall prevail. This drawing and all data herein are provided as confidential materials and shall not be reproduced without written consent of the manufacturer.

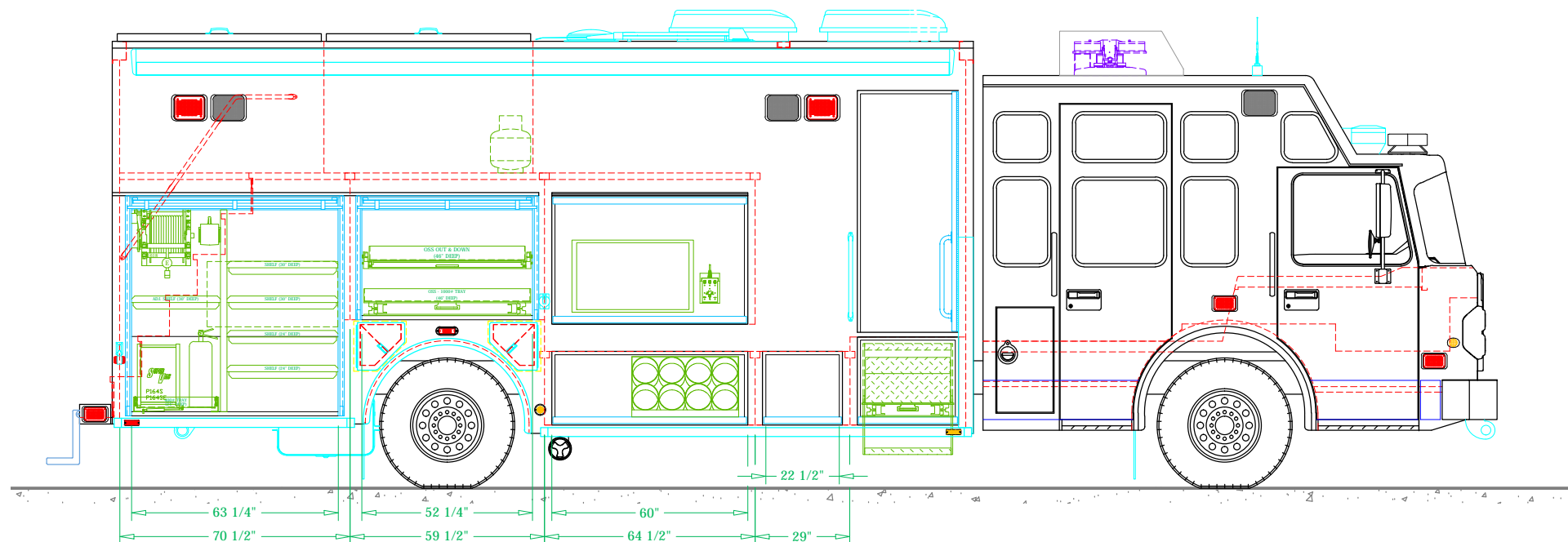
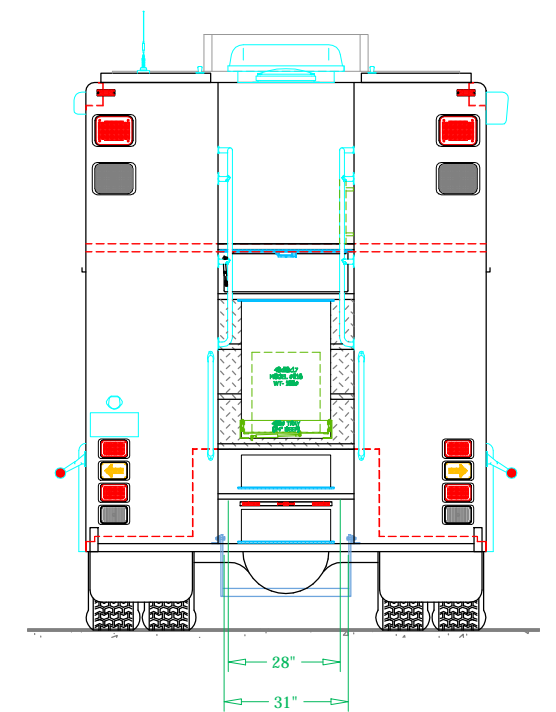
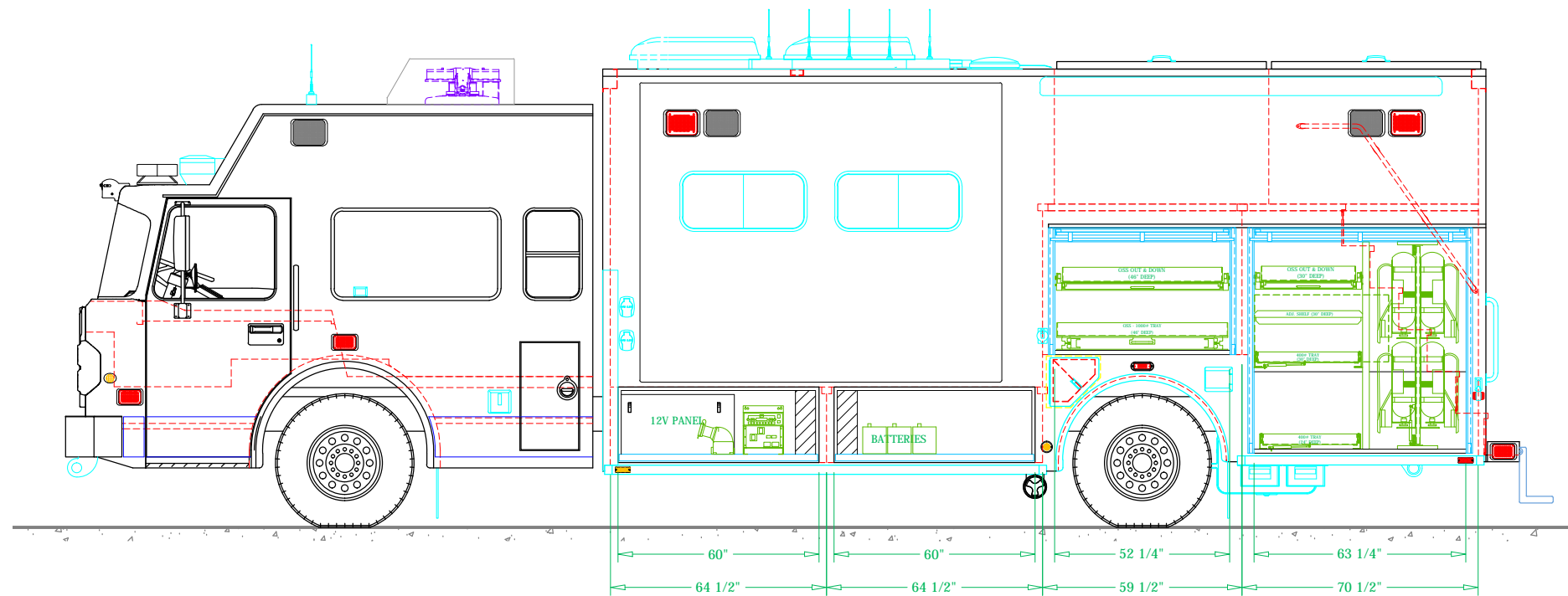
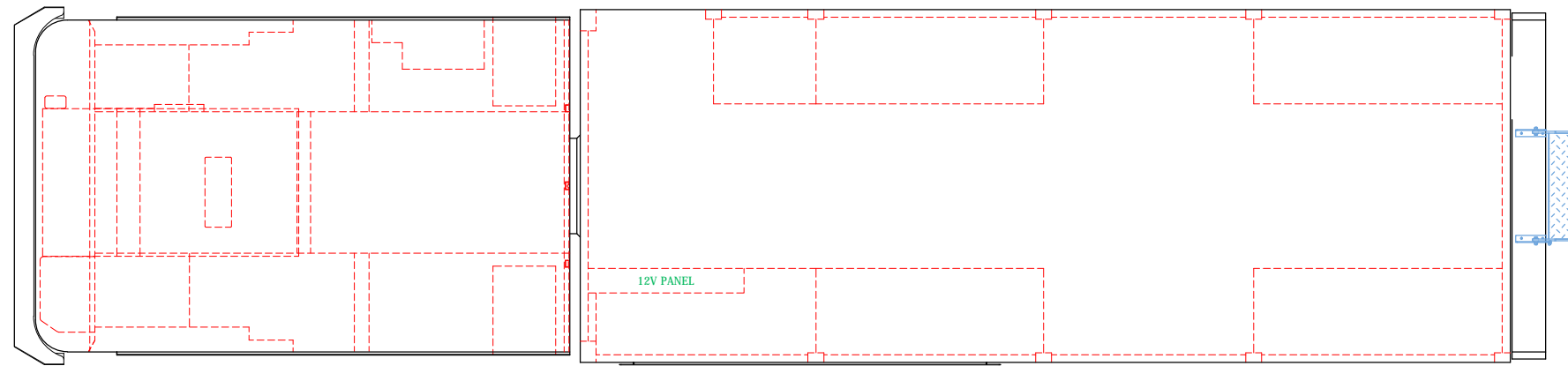



SVI
FORT COLLINS COLORADO

SVI FIRE & RESCUE TRUCKS
3842 REDMAN DRIVE, FORT COLLINS, CO 80524 PHONE 970-297-7100, FAX 970-297-7099

BURLINGTON
FIRE DEPARTMENT

DRAWN BY: HJR	DATE: June 27, 2016	SCALE: 1/4" = 1'-0"
DRAWING NO: Burlington_ON_wi_PreCon1		SHEET 2 OF 3

PRELIMINARY DRAWING - FOR LAYOUT PURPOSES ONLY

REVISIONS			
REV	DESCRIPTION	DATE	BY

NOTE 1: Do not scale drawing. This drawing is for general truck configuration only. All items and dimensions shown are approximate and may vary with final production. The drawing may not provide illustration for all items in the specification. In all situations where the drawing may contradict the specifications, the specifications shall prevail. This drawing and all data herein are provided as confidential materials and shall not be reproduced without written consent of the manufacturer.

PLAN VIEW
CROSS-SECTION

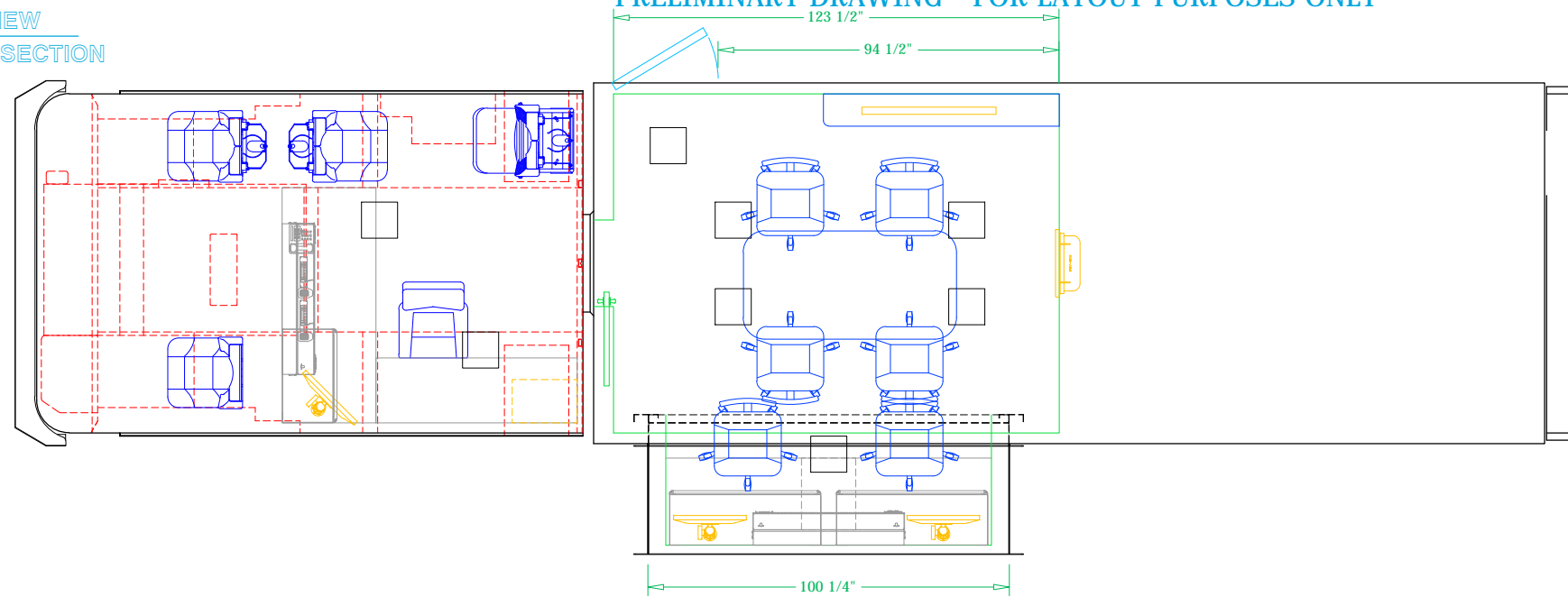

FRONT VIEW
CROSS-SECTION

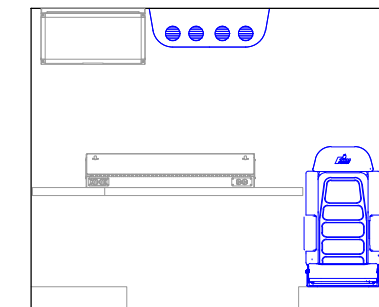

CURBSIDE INTERIOR
CROSS-SECTION

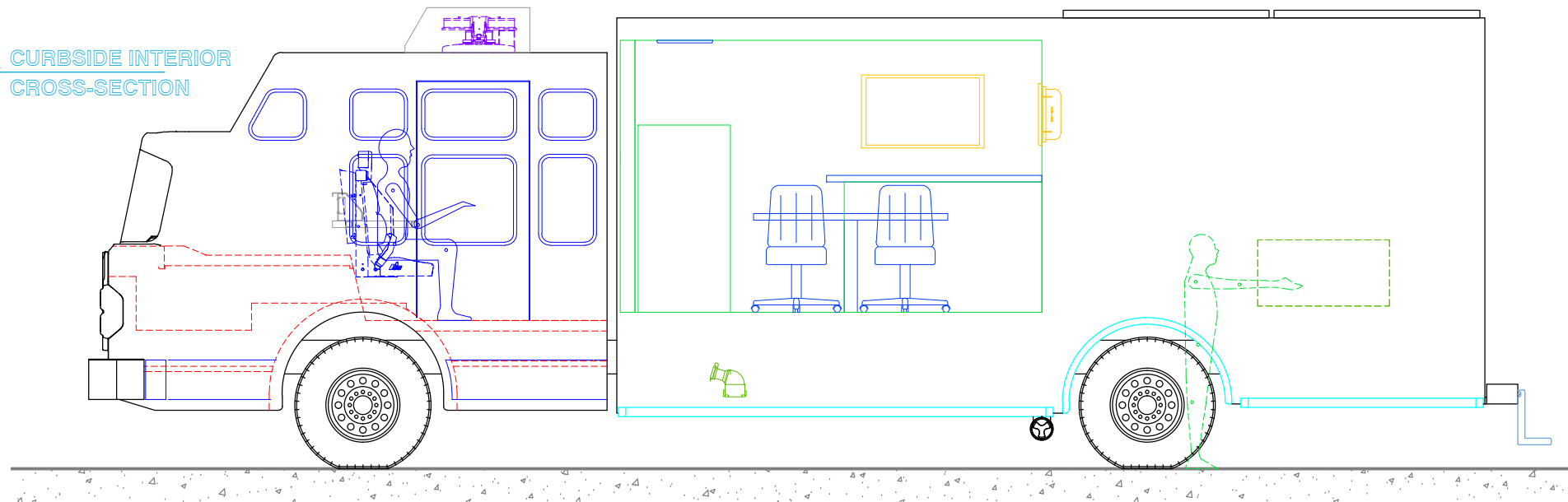

STREETSIDE INTERIOR
CROSS-SECTION

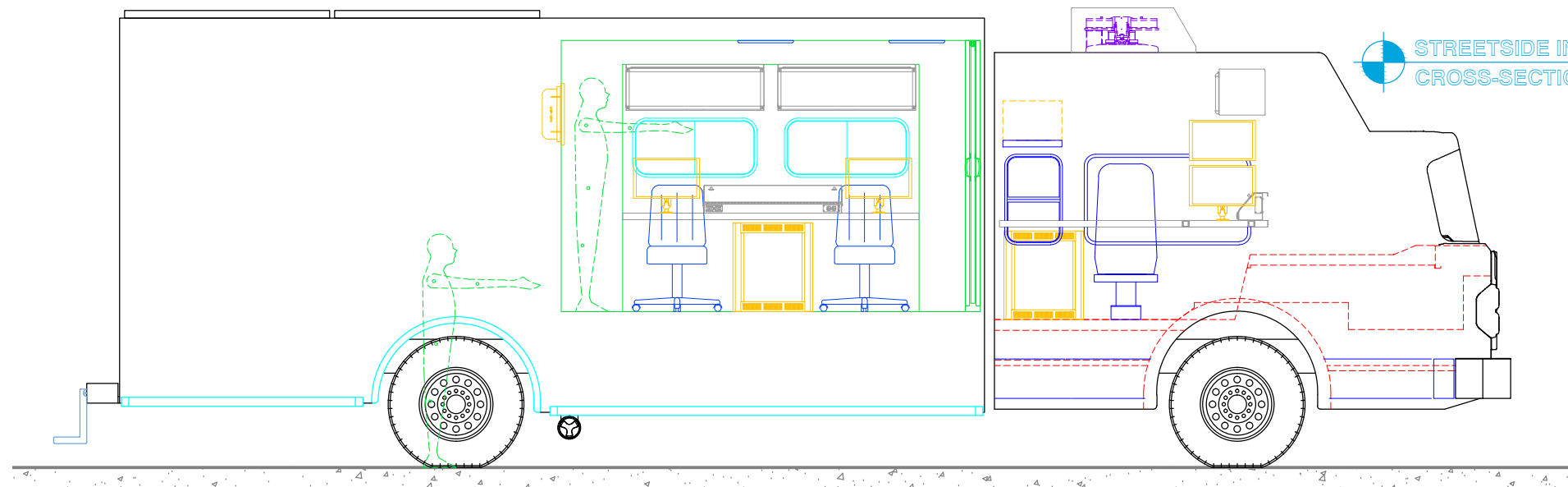

SVI FIRE & RESCUE TRUCKS
3842 REDMAN DRIVE, FORT COLLINS, CO 80524 PHONE 970-297-7100, FAX 970-297-7099

BURLINGTON
FIRE DEPARTMENT