

PRELIMINARY DRAWING - FOR LAYOUT PURPOSES ONLY

REVISIONS			
REV	DESCRIPTION	DATE	BY

NOTE 1: Do not scale drawing. This drawing is for general truck configuration only. All items and dimensions shown are approximate and may vary with final production. The drawing may not provide illustration for all items in the specification. In all situations where the drawing may contradict the specifications, the specifications shall prevail. This drawing and all data herein are provided as confidential materials and shall not be reproduced without written consent of the manufacturer.

NOTE 2: Chassis frame height will change due to axle characteristics, loading and tire dimensions which will affect the overall height dimension shown. Any overall height restrictions should take this into consideration and allow approximately 2-3 inches of tolerance.

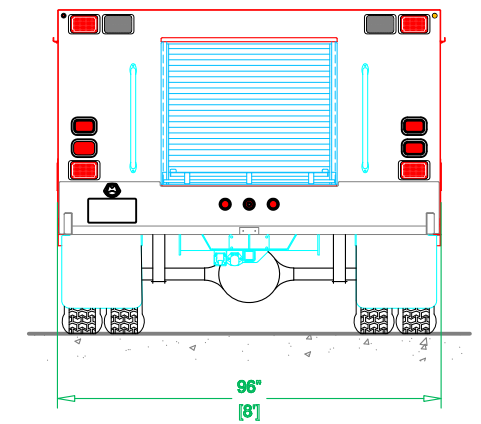
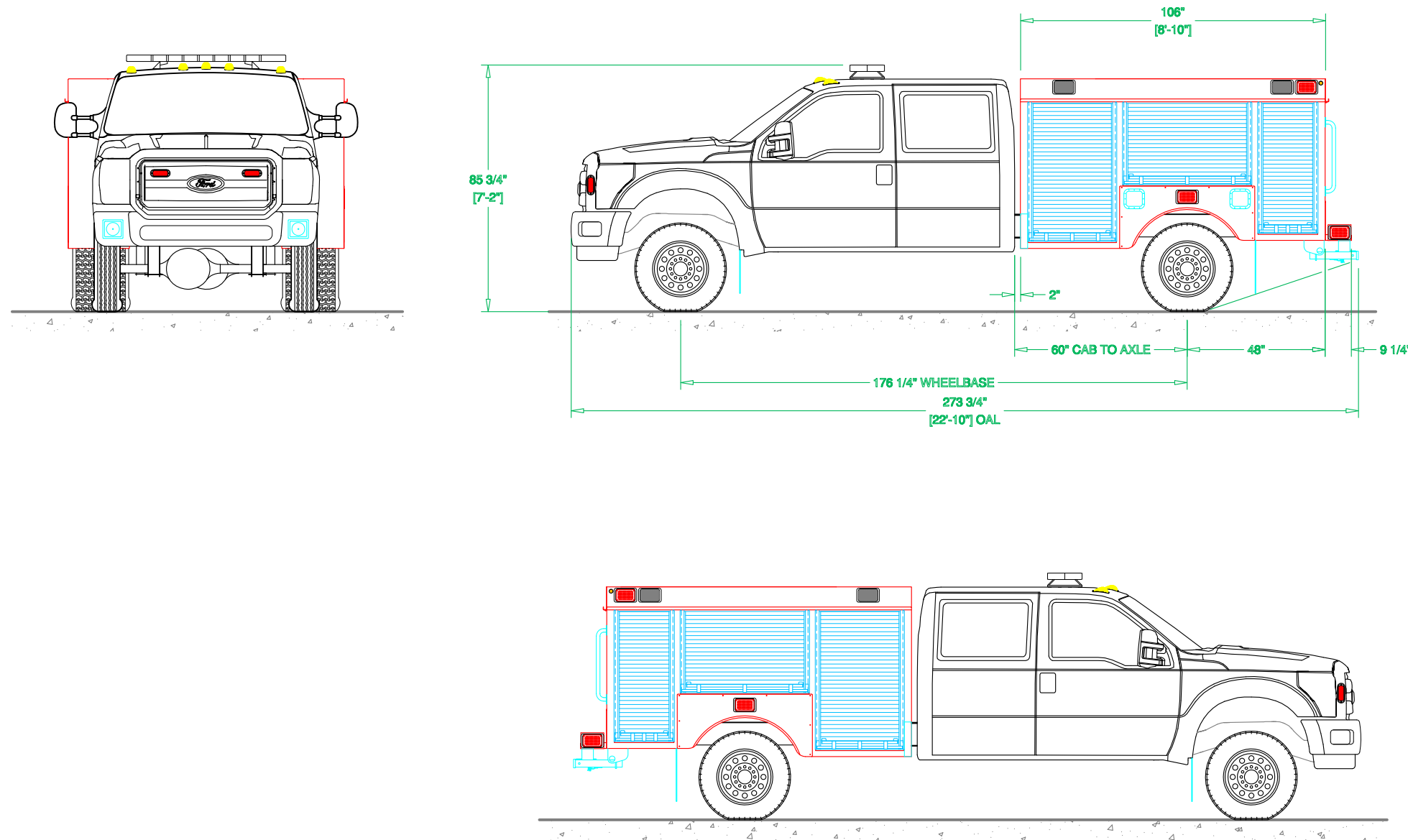

**SVI FIRE & RESCUE TRUCKS**  
3842 REDMAN DRIVE, FORT COLLINS, CO 80524 PHONE 970-297-7100, FAX 970-297-7099

**SAN LEON  
FIRE DEPARTMENT**

BODY SIZE: <b>9' UTILITY BODY</b>	UNIT TYPE: <b>LIGHT RESCUE</b>
BODY MATERIAL: <b>1/8" ALUMINUM</b>	TRUCK NO: <b>SVI #000</b>
CHASSIS TYPE: <b>FORD</b>	WHEELBASE: <b>SEE DWG</b>
<b>F550</b>	CAB TO AXLE: <b>SEE DWG</b>
<b>-</b>	OVERALL LENGTH (OAL): <b>SEE DWG</b>
<b>FOUR DOOR</b>	OVERALL WIDTH (OAW): <b>SEE DWG</b>
	OVERALL HEIGHT (OAH): <b>SEE DWG</b>

DRAWN BY: **JWG**    DATE: **NOVEMBER 28 2016**    SCALE: **1/4" = 1'-0"**  
DRAWING NO: **SanLeon\_TX Jr\_PrelIm2**    SHEET **1** OF **2**

PRELIMINARY DRAWING - FOR LAYOUT PURPOSES ONLY

REVISIONS			
REV	DESCRIPTION	DATE	BY

NOTE 1: Do not scale drawing. This drawing is for general truck configuration only. All items and dimensions shown are approximate and may vary with final production. The drawing may not provide illustration for all items in the specification. In all situations where the drawing may contradict the specifications, the specifications shall prevail. This drawing and all data herein are provided as confidential materials and shall not be reproduced without written consent of the manufacturer.

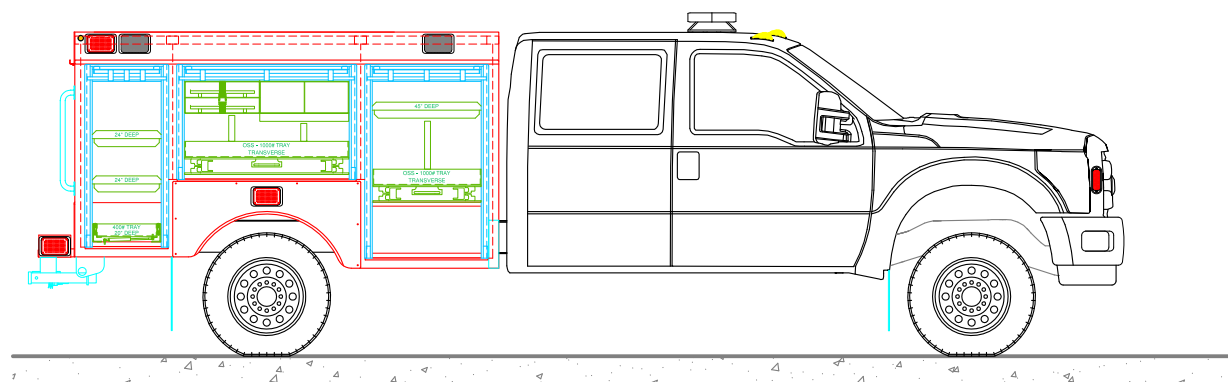
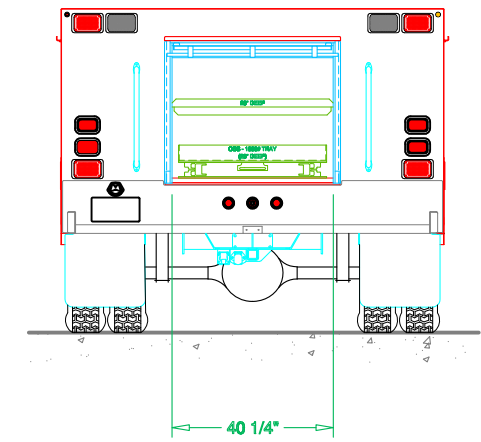
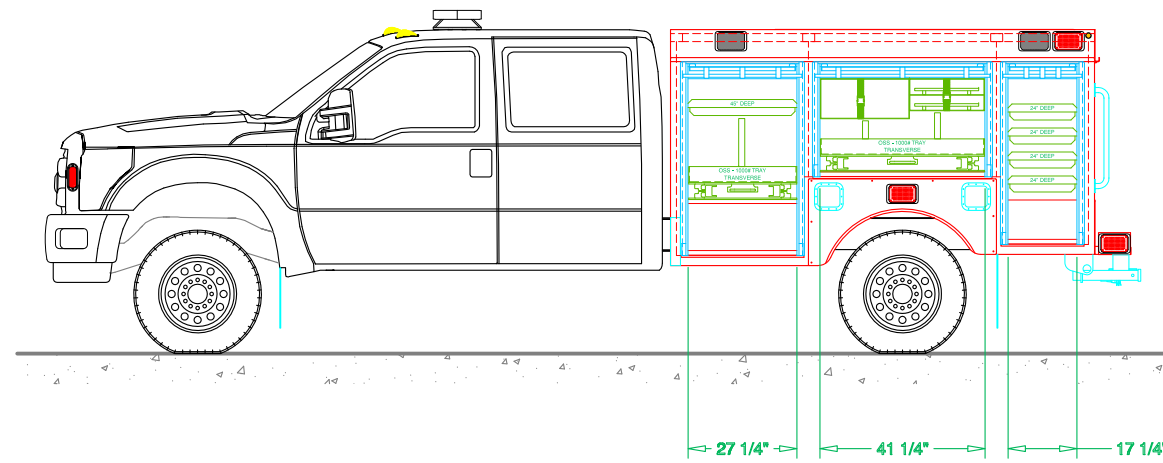



**SVI FIRE & RESCUE TRUCKS**  
3842 REDMAN DRIVE, FORT COLLINS, CO 80524 PHONE 970-297-7100, FAX 970-297-7099

**SAN LEON  
FIRE DEPARTMENT**

DRAWN BY: JWG	DATE: NOVEMBER 28 2018 NOV 28 16	SCALE: 1/4" = 1'-0"
DRAWING NO: SanLeon_TX_Ir_Prelim2		SHEET 2 OF 2