

PRELIMINARY DRAWING - FOR LAYOUT PURPOSES ONLY

REVISIONS			
REV	DESCRIPTION	DATE	BY

NOTE 1: Do not scale drawing. This drawing is for general truck configuration only. All items and dimensions shown are approximate and may vary with final production. The drawing may not provide illustration for all items in the specification. In all situations where the drawing may contradict the specifications, the specifications shall prevail. This drawing and all data herein are provided as confidential materials and shall not be reproduced without written consent of the manufacturer.

NOTE 2: Chassis frame height will change due to axle characteristics, loading and tire dimensions which will effect the overall height dimension shown. Any overall height restrictions should take this into consideration and allow approximately 2-3 inches of tolerance.

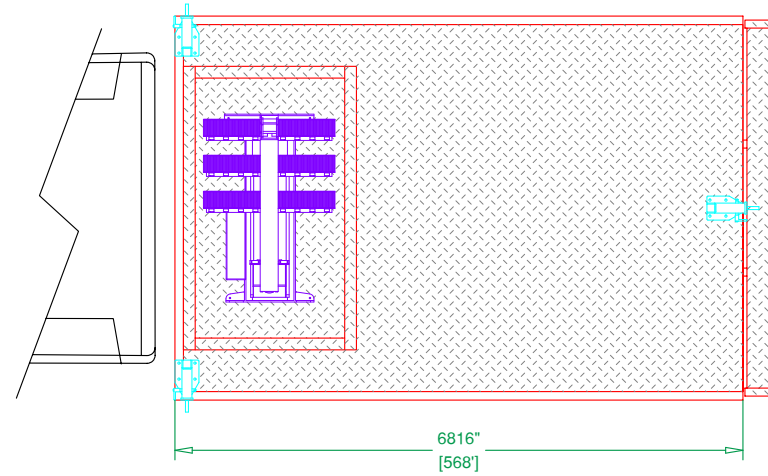

RIGID 30° LED SERIES  
SPOT/FLOOD SCENE LIGHTS

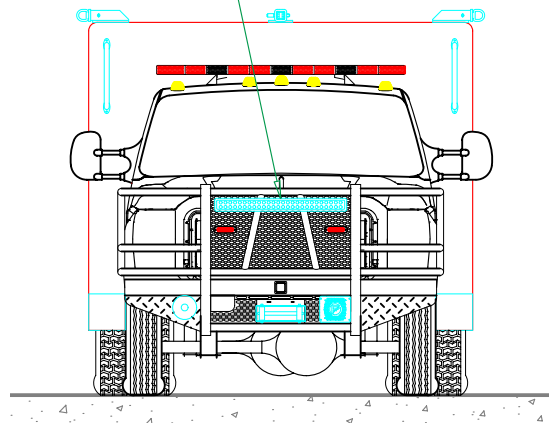

(8) WHELEN ION SERIES  
RED LED WARNING LIGHTS  
(3 EACH SIDE, 2 FRONT)

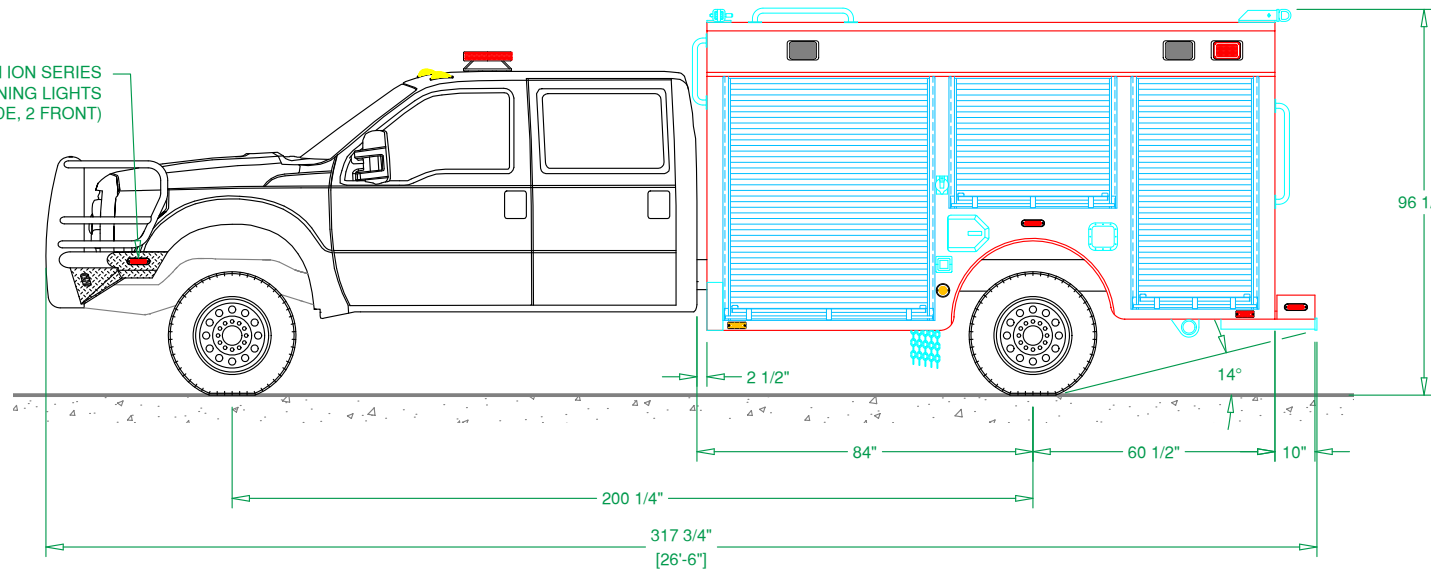

WHELEN C6 LED SERIES  
INDIVIDUAL LIGHTS  
FOR TAIL LIGHTS

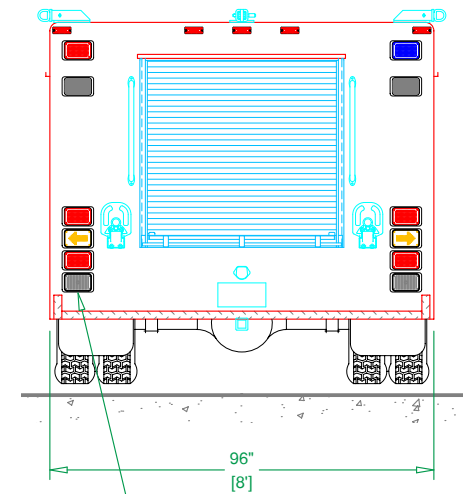

(6) WHELEN 600 SERIES  
12 LED SCENE LIGHTS  
(2 EACH SIDE, 2 REAR)

(4) WHELEN C6 SERIES  
RED LED WARNING LIGHTS  
(1 EACH SIDE, 2 REAR)

(4) WHELEN C6 SERIES  
RED LED WARNING LIGHTS  
(1 EACH SIDE, 2 FRONT)

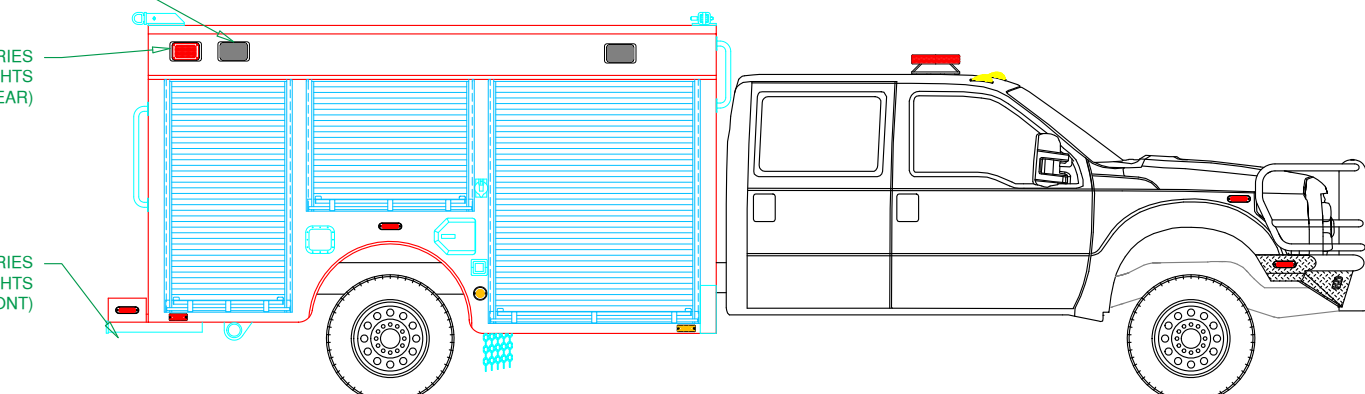

SVI FIRE & RESCUE TRUCKS  
3842 REDMAN DRIVE, FORT COLLINS, CO 80524 PHONE 970-297-7100, FAX 970-297-7099

GUNNISON  
FIRE DEPARTMENT

BODY SIZE: 12' BODY	UNIT TYPE: LIGHT RESCUE
BODY MATERIAL: 3/16" ALUMINUM	TRUCK NO: SVI #xxx
CHASSIS TYPE: FORD	WHEELBASE: SEE DWG
F550	CAB TO AXLE: SEE DWG
-	OVERALL LENGTH (OAL): SEE DWG
FOUR DOOR	OVERALL WIDTH (CAW): SEE DWG
	OVERALL HEIGHT (OAH): SEE DWG

PRELIMINARY DRAWING - FOR LAYOUT PURPOSES ONLY

REVISIONS			
REV	DESCRIPTION	DATE	BY

NOTE 1: Do not scale drawing. This drawing is for general truck configuration only. All items and dimensions shown are approximate and may vary with final production. The drawing may not provide illustration for all items in the specification. In all situations where the drawing may contradict the specifications, the specifications shall prevail. This drawing and all data herein are provided as confidential materials and shall not be reproduced without written consent of the manufacturer.

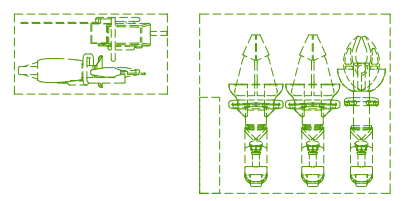
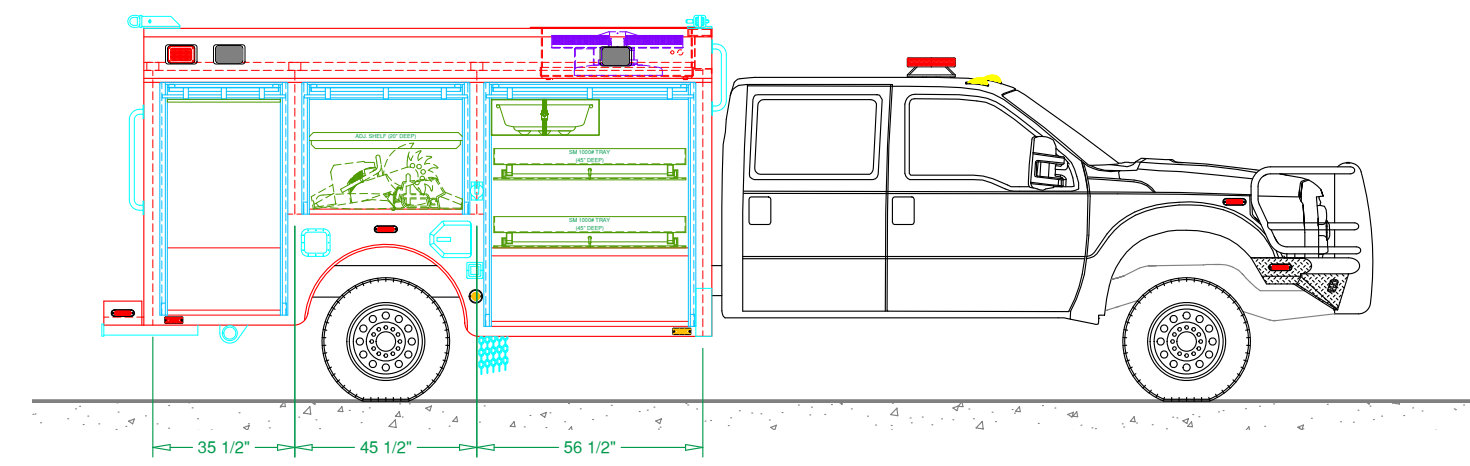
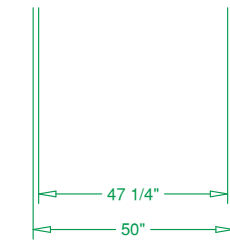
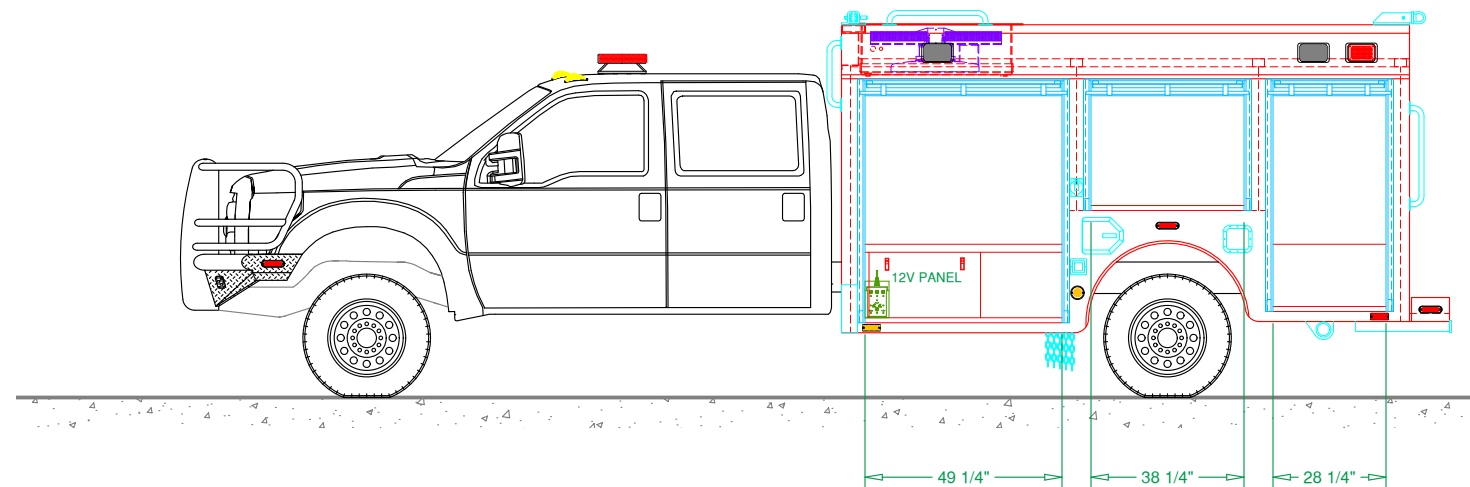



**SVI**  
FORT COLLINS COLORADO

SVI FIRE & RESCUE TRUCKS  
3842 REDMAN DRIVE, FORT COLLINS, CO. 80524 PHONE: 970-297-7100, FAX: 970-297-7099

**GUNNISON**  
FIRE DEPARTMENT

DRAWN BY: HJR	DATE: Feb. 26, 18	SCALE: 1/4" = 1'-0"
DRAWING NO: Gunnison_CO_Jr_PreLim1		SHEET 2 OF 2

