

PRELIMINARY DRAWING - FOR LAYOUT PURPOSES ONLY

REVISIONS			
REV	DESCRIPTION	DATE	BY

NOTE 1: Do not scale drawing. This drawing is for general truck configuration only. All items and dimensions shown are approximate and may vary with final production. The drawing may not provide illustration for all items in the specification. In all situations where the drawing may contradict the specifications, the specifications shall prevail. This drawing and all data herein are provided as confidential materials and shall not be reproduced without written consent of the manufacturer.

NOTE 2: Chassis frame height will change due to axle characteristics, loading and tire dimensions which will effect the overall height dimension shown. Any overall height restrictions should take this into consideration and allow approximately 2-3 inches of tolerance.

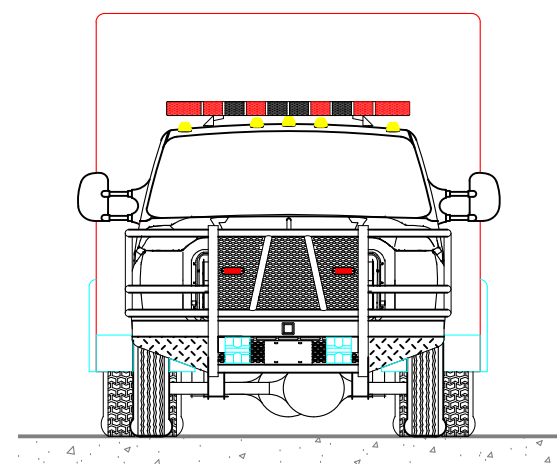
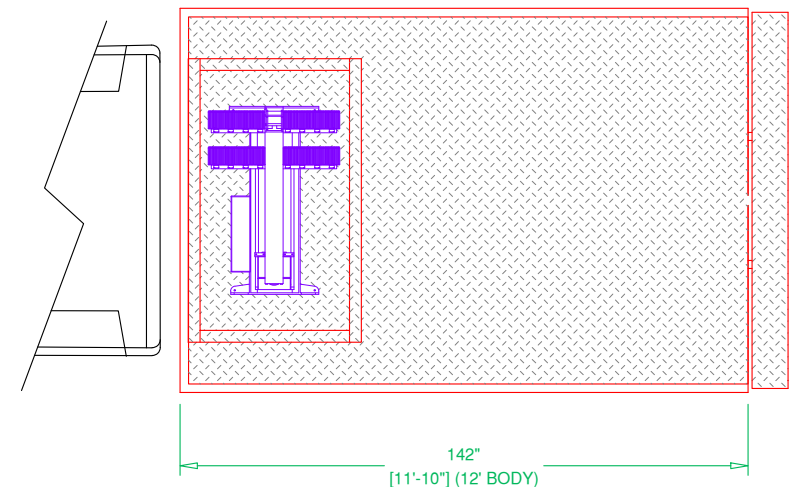

RANCH HAND BUMPER

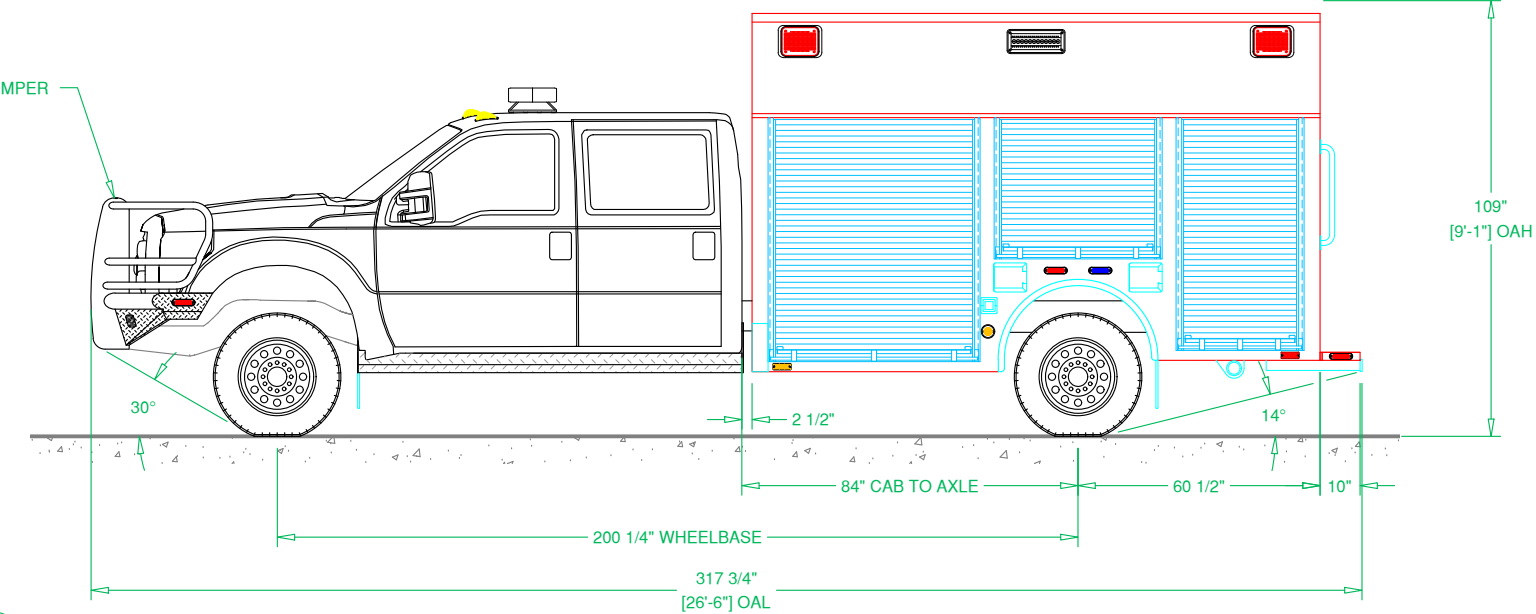

(6) WHELEN C9 SERIES  
RED LED WARNING LIGHTS  
(2 EACH SIDE, 2 REAR)

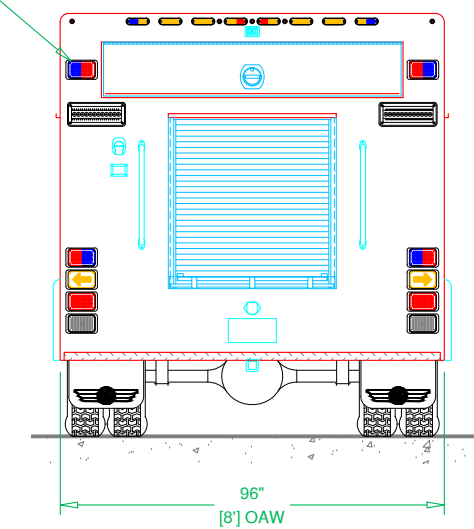

(6) WHELEN C9 SERIES  
RED LED WARNING LIGHTS  
(2 EACH SIDE, 2 REAR)

(8) WHELEN ION SERIES  
RED LED WARNING LIGHTS  
(3 EACH SIDE, 2 FRONT)

(2) WHELEN ION SERIES  
BLUE LED WARNING LIGHTS  
(1 EACH SIDE)

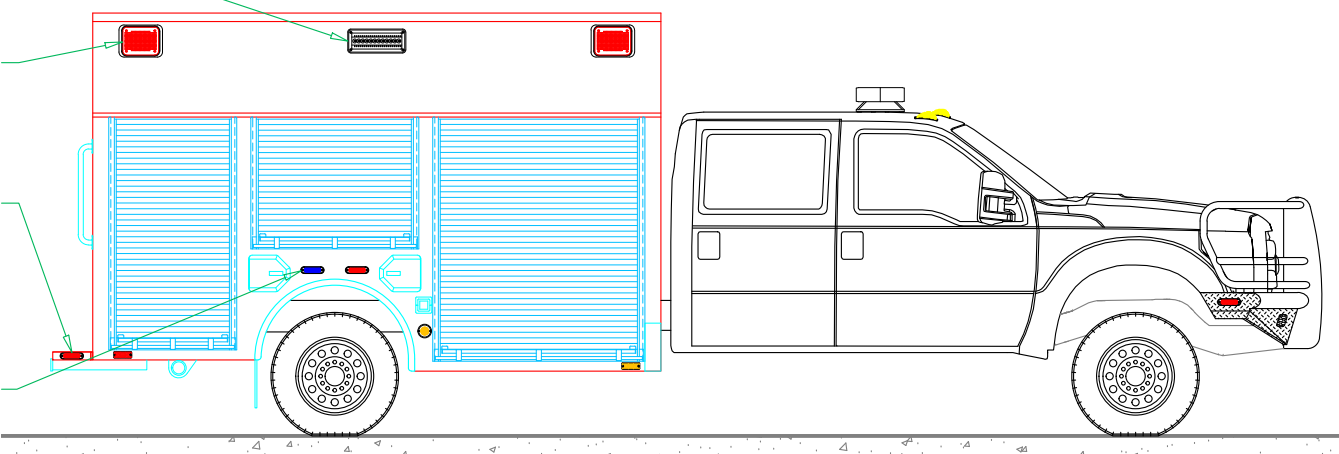

SVI FIRE & RESCUE TRUCKS  
3842 REDMAN DRIVE, FORT COLLINS, CO 80524 PHONE 970-297-7100, FAX 970-297-7099

CLARENCE CENTER  
VOLUNTEER FIRE COMPANY

BODY SIZE: 12' BODY	UNIT TYPE: LIGHT RESCUE
BODY MATERIAL: 3/16" ALUMINUM	TRUCK NO: SVI #xxx
CHASSIS TYPE: FORD	WHEELBASE: SEE DWG
F550	CAB TO AXLE: SEE DWG
-	OVERALL LENGTH (OAL): SEE DWG
FOUR DOOR	OVERALL WIDTH (OAW): SEE DWG
	OVERALL HEIGHT (OAH): SEE DWG

DRAWN BY: HJR	DATE: July 30, 2018	SCALE: 1/4" = 1'-0"
DRAWING NO: ClarenceCenter_NY_Ir_PreCon1		SHEET 1 OF 2

PRELIMINARY DRAWING - FOR LAYOUT PURPOSES ONLY

REVISIONS			
REV	DESCRIPTION	DATE	BY

NOTE 1: Do not scale drawing. This drawing is for general truck configuration only. All items and dimensions shown are approximate and may vary with final production. The drawing may not provide illustration for all items in the specification. In all situations where the drawing may contradict the specifications, the specifications shall prevail. This drawing and all data herein are provided as confidential materials and shall not be reproduced without written consent of the manufacturer.

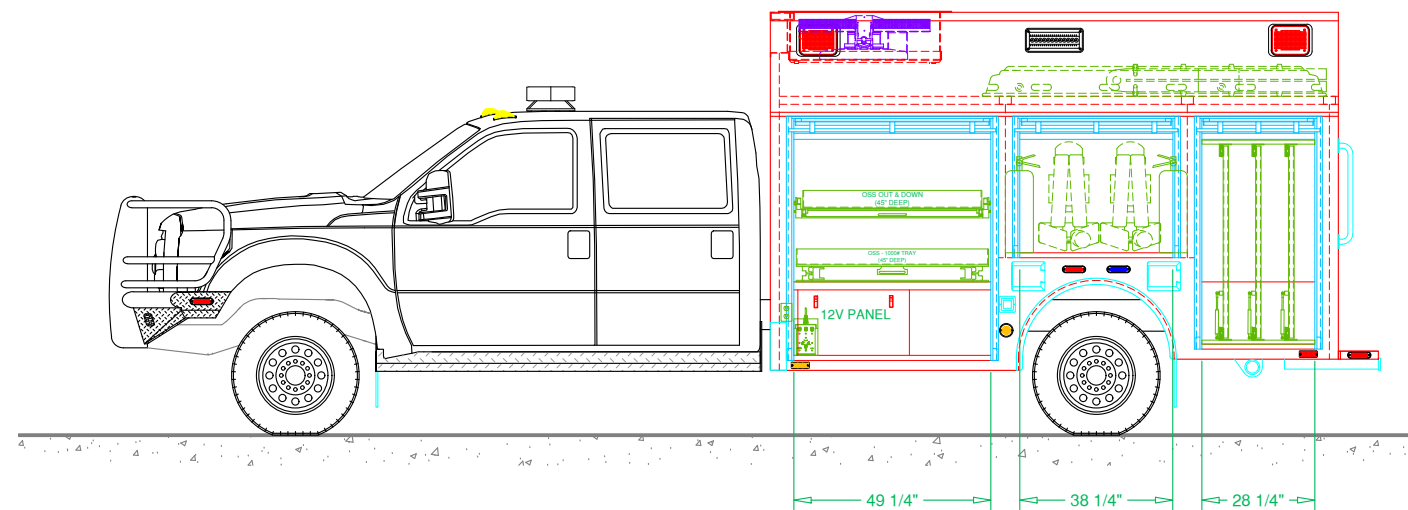
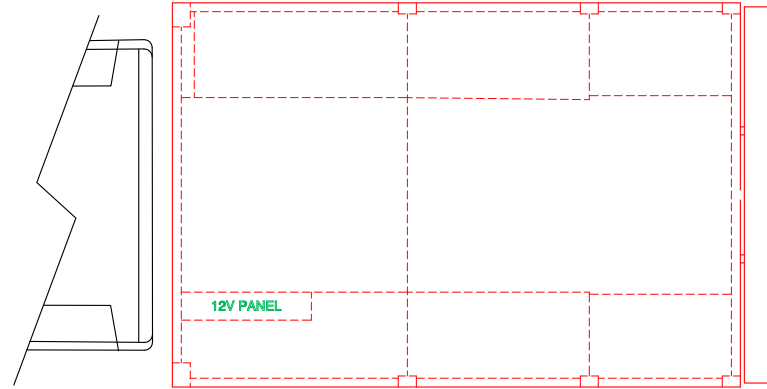

BOAT OARS MODULES  
(NEED DIMENSIONS TO ENSURE FIT)

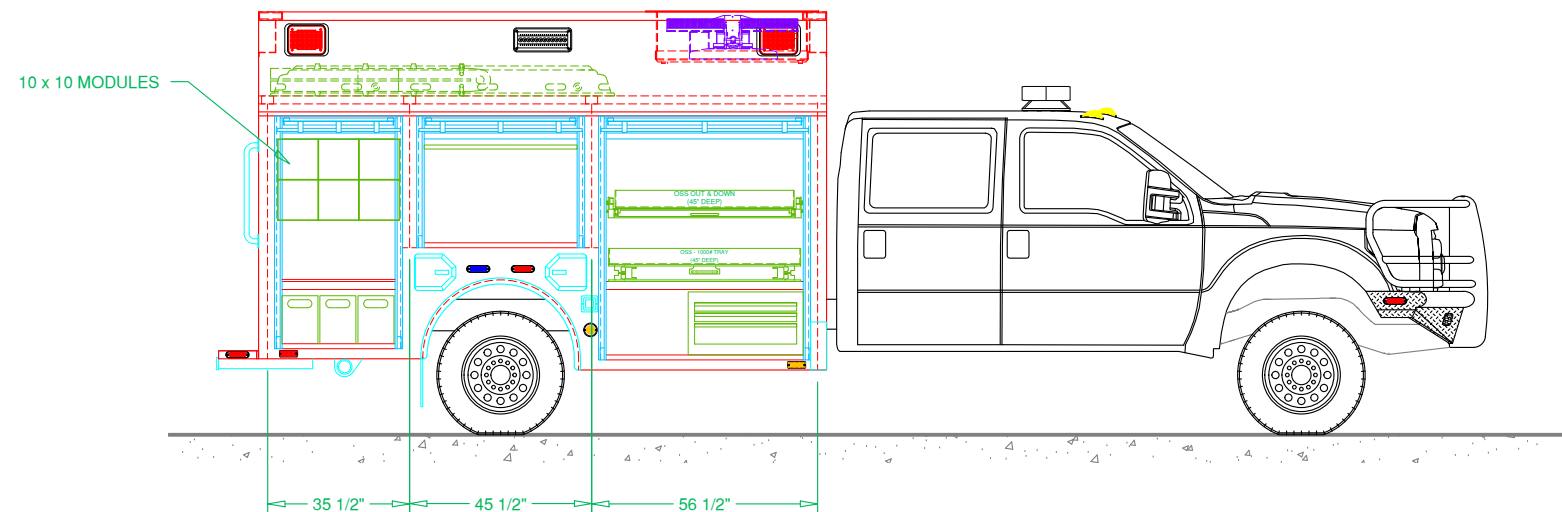
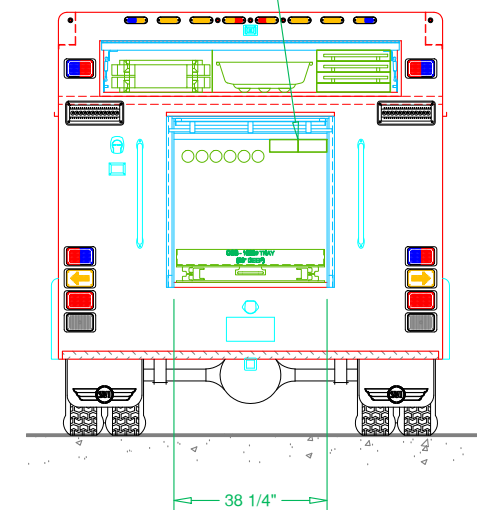



SVI FIRE & RESCUE TRUCKS  
3842 REDMAN DRIVE, FORT COLLINS, CO 80524 PHONE 970-297-7100, FAX 970-297-7099

**CLARENCE CENTER  
VOLUNTEER FIRE COMPANY**

DRAWN BY: HJR	DATE: Jul. 30, 18	SCALE: 1/4" = 1'-0"
DRAWING NO: ClarenceCenter_NY Jr_PreCon1	SHEET 2 OF 2	

PRELIMINARY DRAWING - FOR LAYOUT PURPOSES ONLY

REVISIONS			
REV	DESCRIPTION	DATE	BY

NOTE 1: Do not scale drawing. This drawing is for general truck configuration only. All items and dimensions shown are approximate and may vary with final production. The drawing may not provide illustration for all items in the specification. In all situations where the drawing may contradict the specifications, the specifications shall prevail. This drawing and all data herein are provided as confidential materials and shall not be reproduced without written consent of the manufacturer.

NOTE 2: Chassis frame height will change due to axle characteristics, loading and tire dimensions which will effect the overall height dimension shown. Any overall height restrictions should take this into consideration and allow approximately 2-3 inches of tolerance.

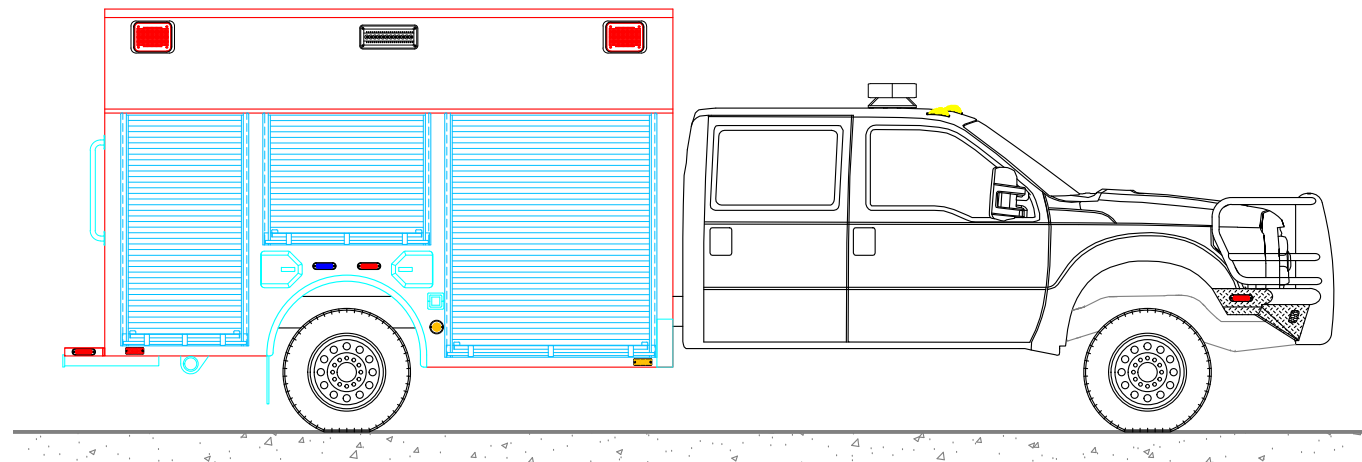
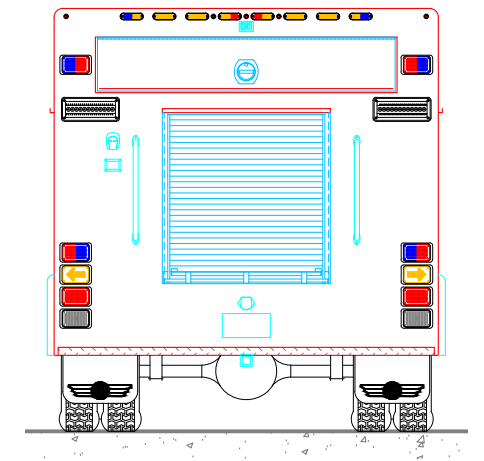
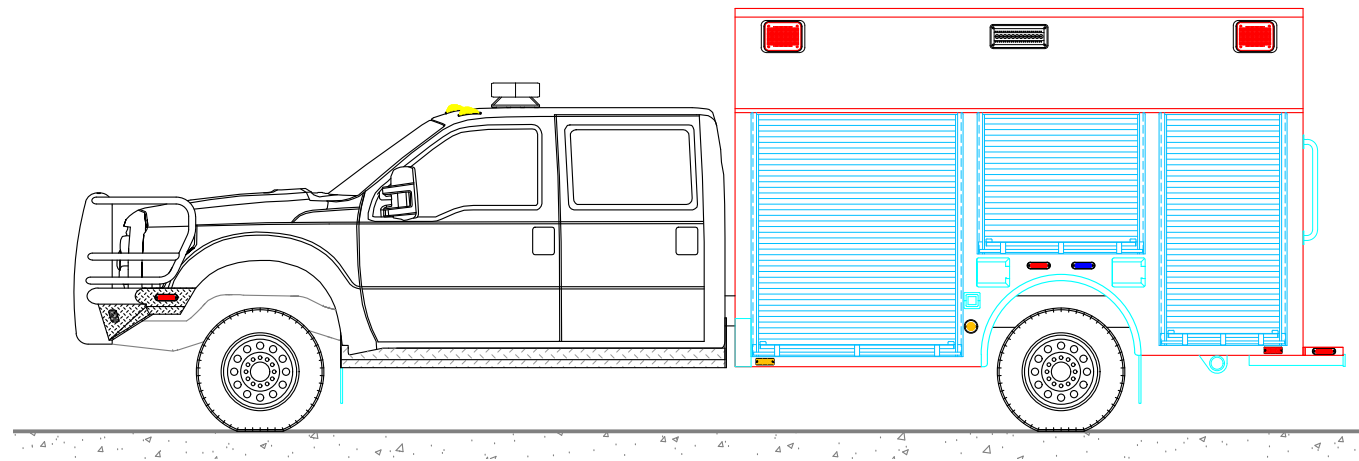
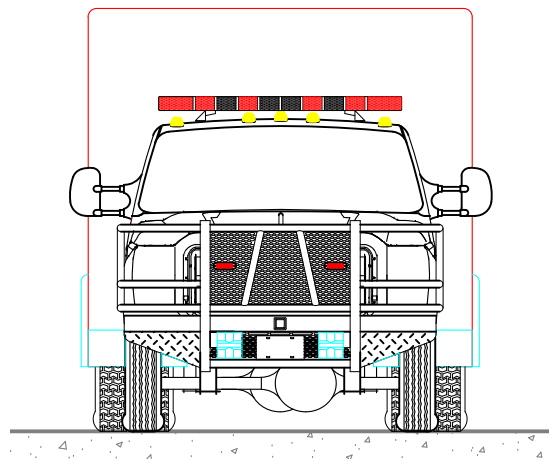
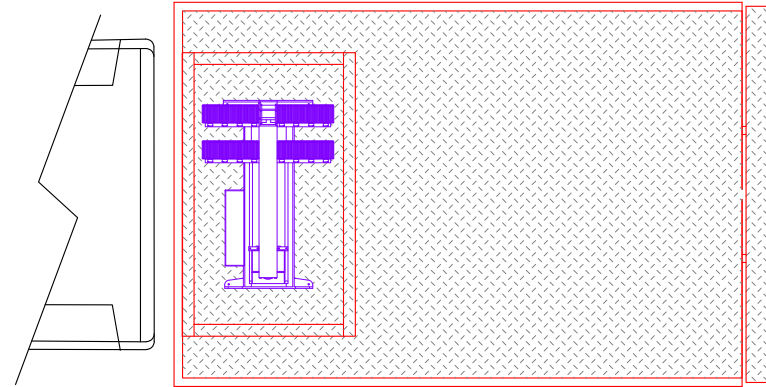



**SVI**  
FORT COLLINS COLORADO

SVI FIRE & RESCUE TRUCKS  
3842 REDMAN DRIVE, FORT COLLINS, CO 80524 PHONE 970-297-7100, FAX 970-297-7099

**CLARENCE CENTER  
VOLUNTEER FIRE COMPANY**

BODY SIZE: 12' BODY	UNIT TYPE: LIGHT RESCUE
BODY MATERIAL: 3/16" ALUMINUM	TRUCK NO: SVI #xxx
CHASSIS TYPE: FORD	WHEELBASE: SEE DWG
F550	CAB TO AXLE: SEE DWG
-	OVERALL LENGTH (OAL): SEE DWG
FOUR DOOR	OVERALL WIDTH (OAW): SEE DWG
	OVERALL HEIGHT (OAH): SEE DWG

DRAWN BY: HJR    DATE: July 30, 2018    SCALE: 1/4" = 1'-0"  
DRAWING NO: ClarenceCenter\_NY\_Ir\_PreCon1    SHEET 1 OF 2