

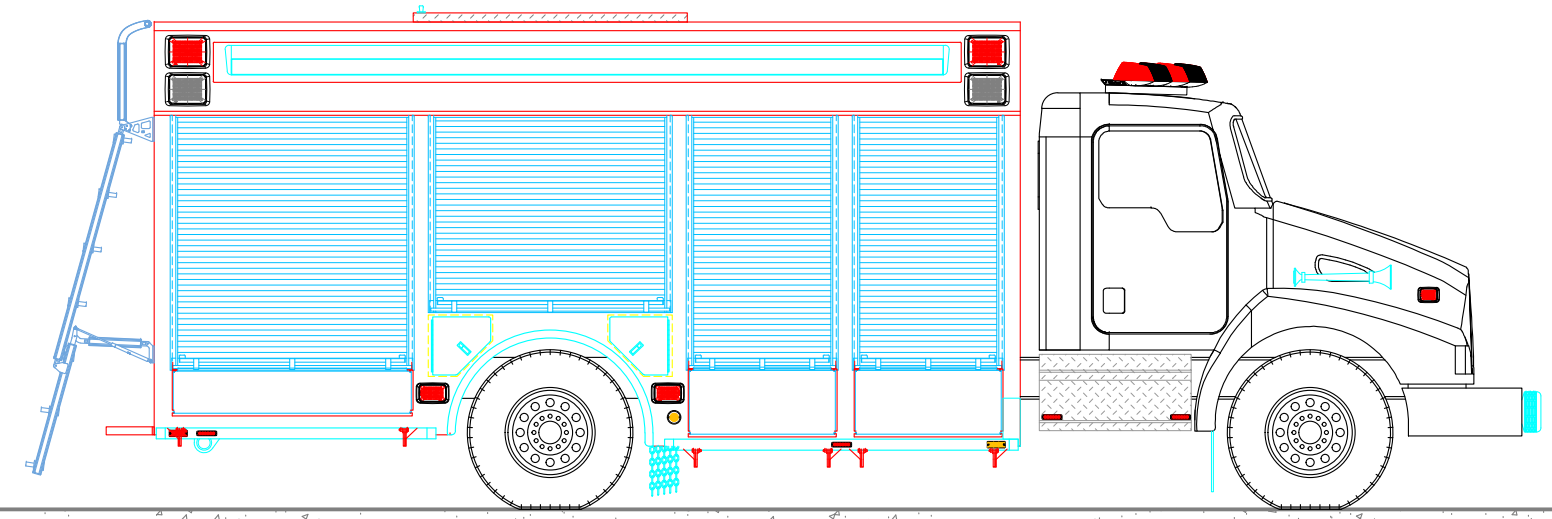
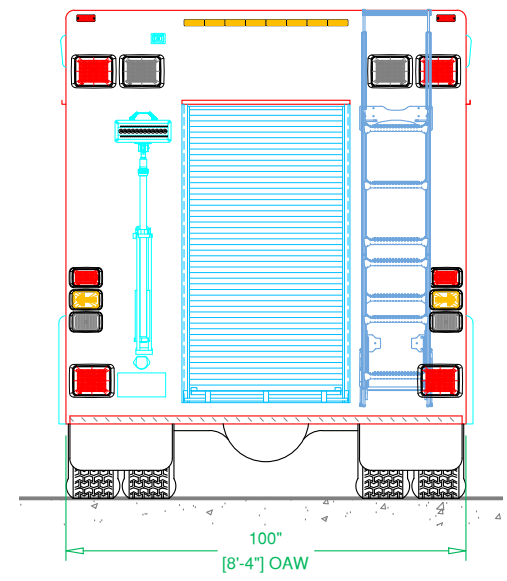
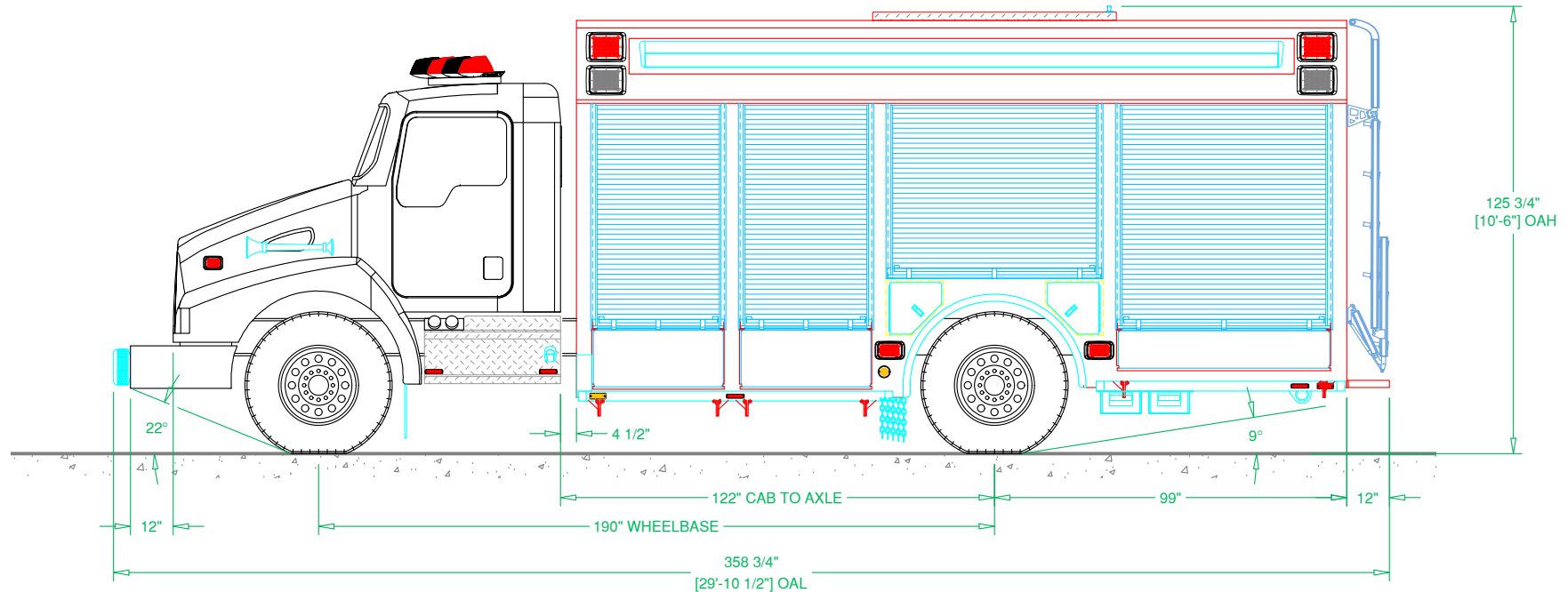
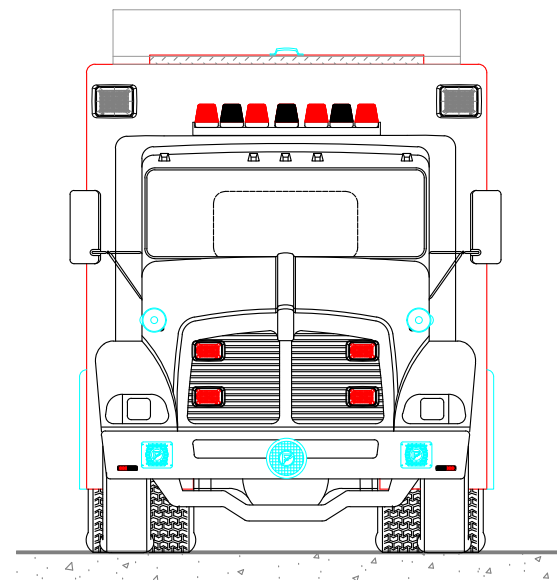
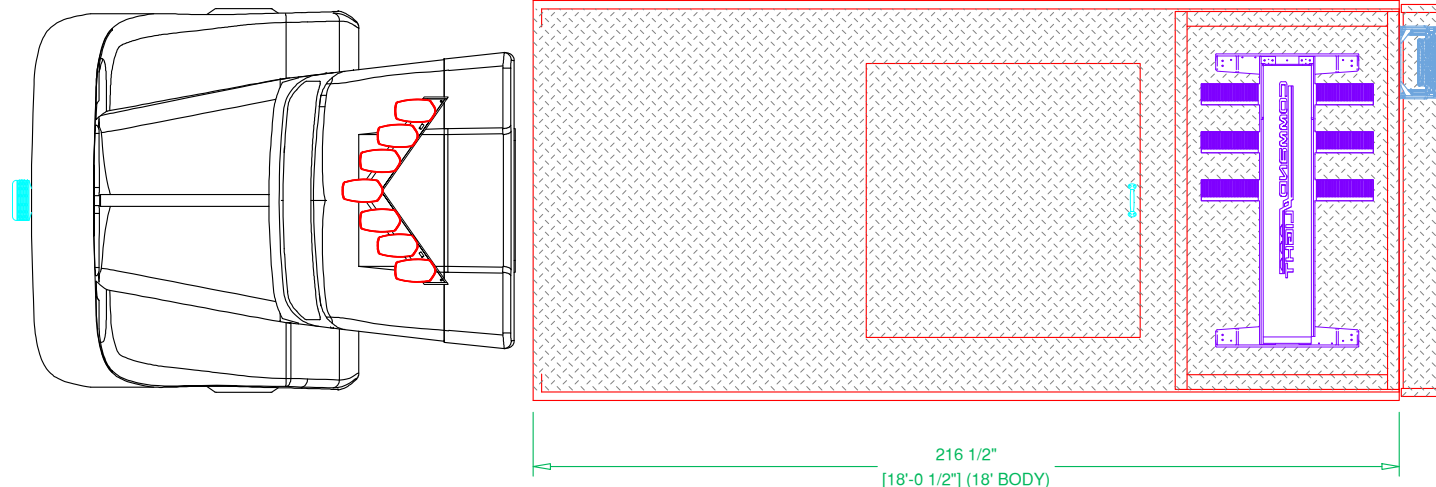

PRELIMINARY DRAWING - FOR LAYOUT PURPOSES ONLY

REVISIONS			
REV	DESCRIPTION	DATE	BY

NOTE 1: Do not scale drawing. This drawing is for general truck configuration only. All items and dimensions shown are approximate and may vary with final production. The drawing may not provide illustration for all items in the specification. In all situations where the drawing may contradict the specifications, the specifications shall prevail. This drawing and all data herein are provided as confidential materials and shall not be reproduced without written consent of the manufacturer.

NOTE 2: Chassis frame height will change due to axle characteristics, loading and tire dimensions which will effect the overall height dimension shown. Any overall height restrictions should take this into consideration and allow approximately 2-3 inches of tolerance.





**SVI**  
FORT COLLINS COLORADO

SVI FIRE & RESCUE TRUCKS  
3842 REDMAN DRIVE, FORT COLLINS, CO 80524 PHONE 970-297-7100, FAX 970-297-7099

**GWINNETT COUNTY**  
**FIRE AND EMERGENCY SERVICES**

BODY SIZE: 18' BODY	UNIT TYPE: AIR/LIGHT
BODY MATERIAL: 3/16" ALUMINUM	TRUCK NO: SVI #xxx
CHASSIS TYPE: KENWORTH	WHEELBASE: SEE DWG
T370	CAB TO AXLE: SEE DWG
-	OVERALL LENGTH (OAL): SEE DWG
-	OVERALL WIDTH (OAW): SEE DWG
TWO DOOR	OVERALL HEIGHT (OAH): SEE DWG

DRAWN BY: HJR	DATE: May 24, 2019	SCALE: 1/4" = 1'-0"
DRAWING NO: GwinnettCo_GA_al PreCon2	SHEET 1 OF 2	

PRELIMINARY DRAWING - FOR LAYOUT PURPOSES ONLY

REVISIONS			
REV	DESCRIPTION	DATE	BY

NOTE 1: Do not scale drawing. This drawing is for general truck configuration only. All items and dimensions shown are approximate and may vary with final production. The drawing may not provide illustration for all items in the specification. In all situations where the drawing may contradict the specifications, the specifications shall prevail. This drawing and all data herein are provided as confidential materials and shall not be reproduced without written consent of the manufacturer.

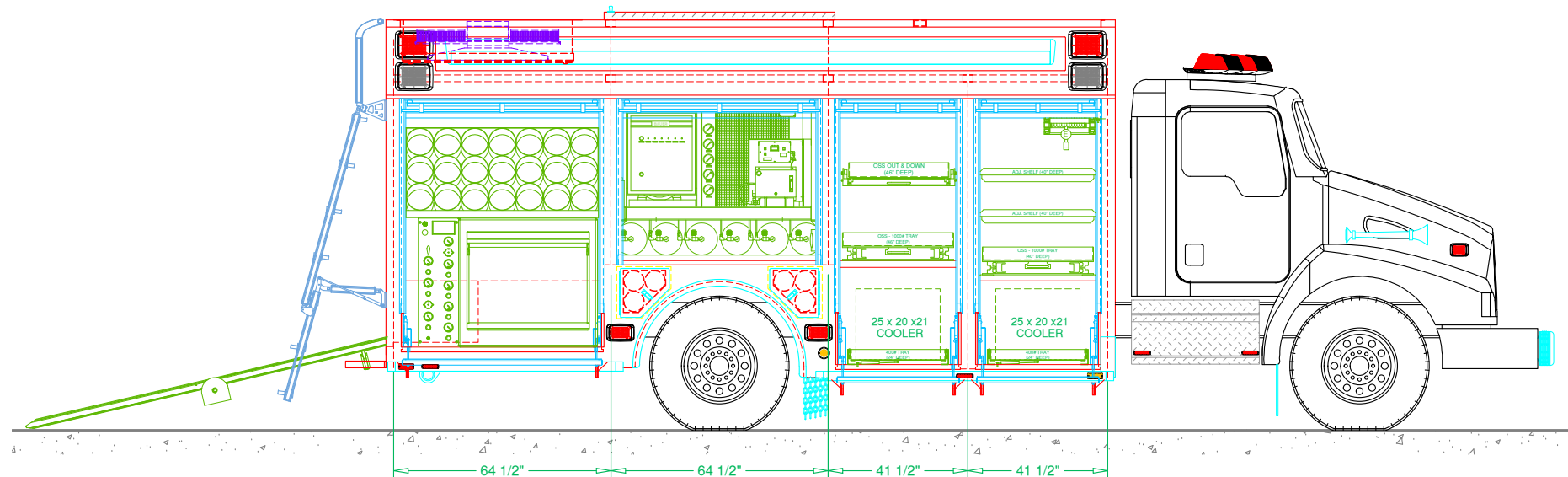
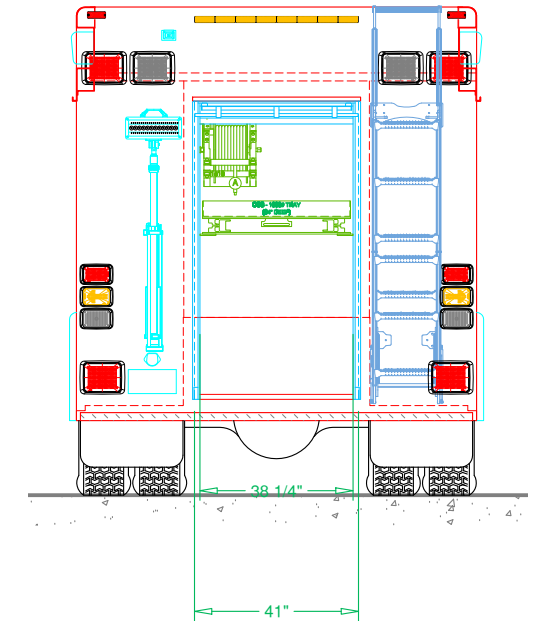
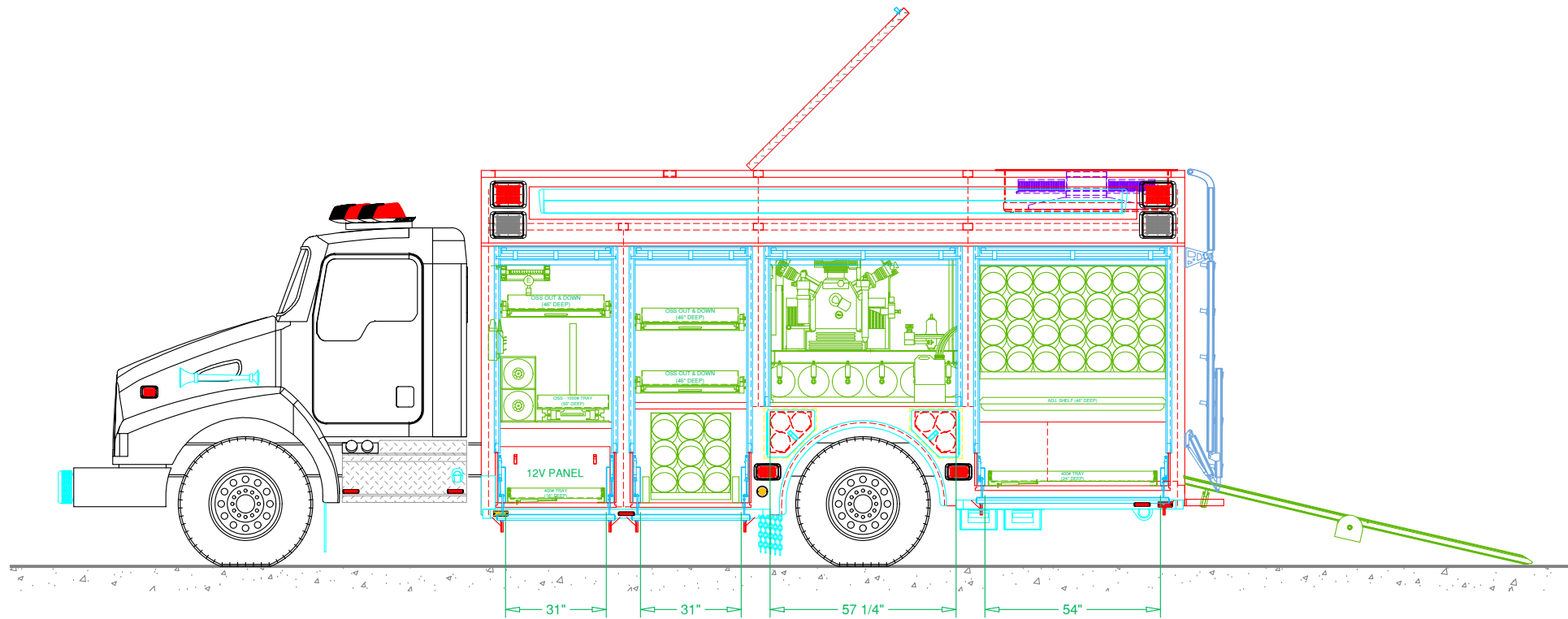
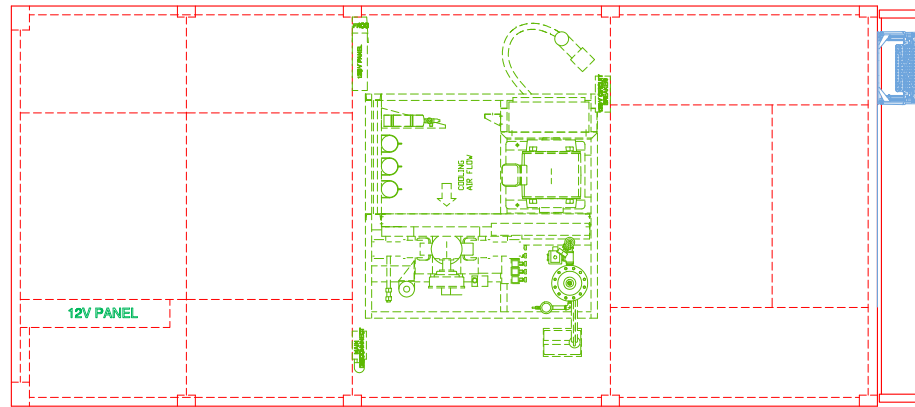
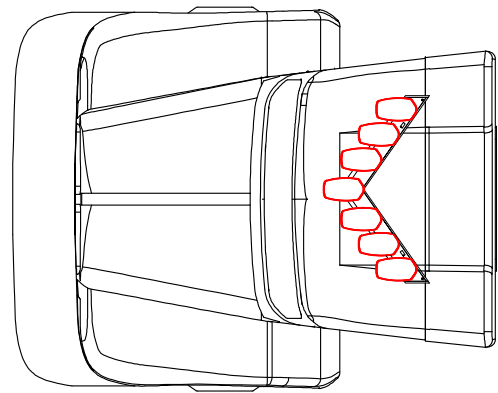



SVI FIRE & RESCUE TRUCKS  
3842 REDMAN DRIVE, FORT COLLINS, CO 80524 PHONE 970-297-7100, FAX 970-297-7099

**GWINNETT COUNTY**  
**FIRE AND EMERGENCY SERVICES**

DRAWN BY: HJR	DATE: May. 24, 19	SCALE: 1/4" = 1'-0"
DRAWING NO: GwinnettCo_GA_al PreCon2		SHEET 2 OF 2