

REVISIONS			
REV	DESCRIPTION	DATE	BY

NOTE 1: Do not scale drawing. This drawing is for general truck configuration only. All items and dimensions shown are approximate and may vary with final production. The drawing may not provide illustration for all items in the specification. In all situations where the drawing may contradict the specifications, the specifications shall prevail. This drawing and all data herein are provided as confidential materials and shall not be reproduced without written consent of the manufacturer.

NOTE 2: Chassis frame height will change due to axle characteristics, loading and tire dimensions which will effect the overall height dimension shown. Any overall height restrictions should take this into consideration and allow approximately 2-3 inches of tolerance.

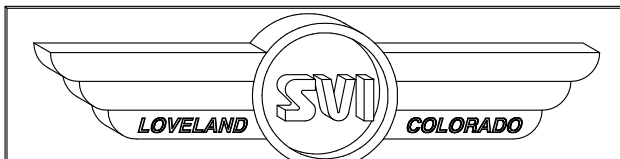
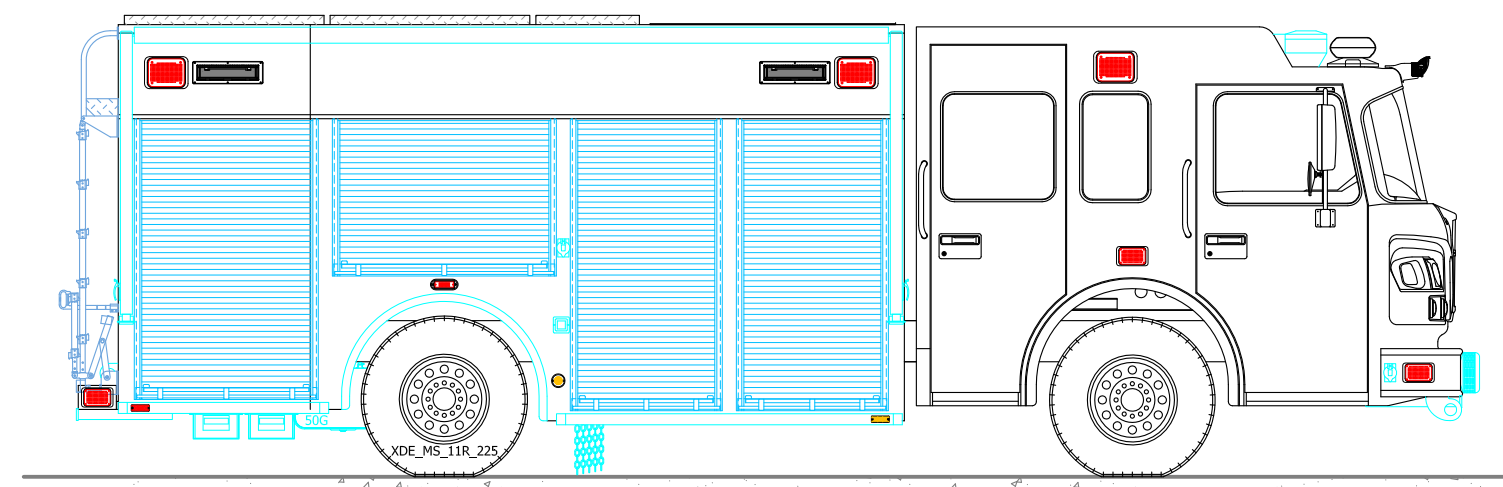
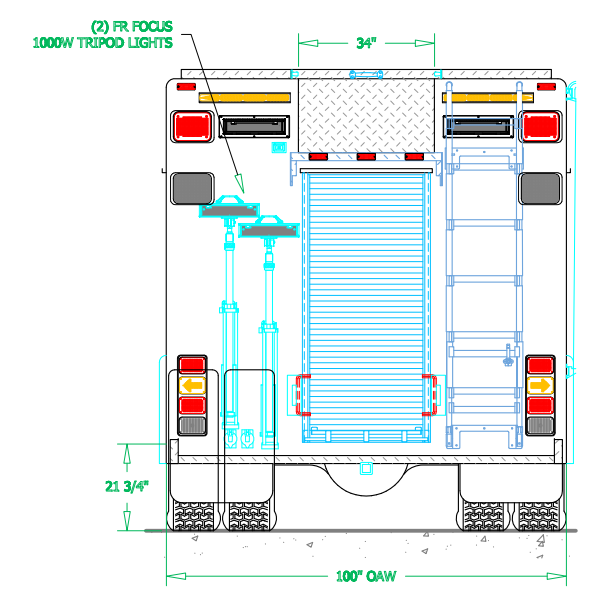
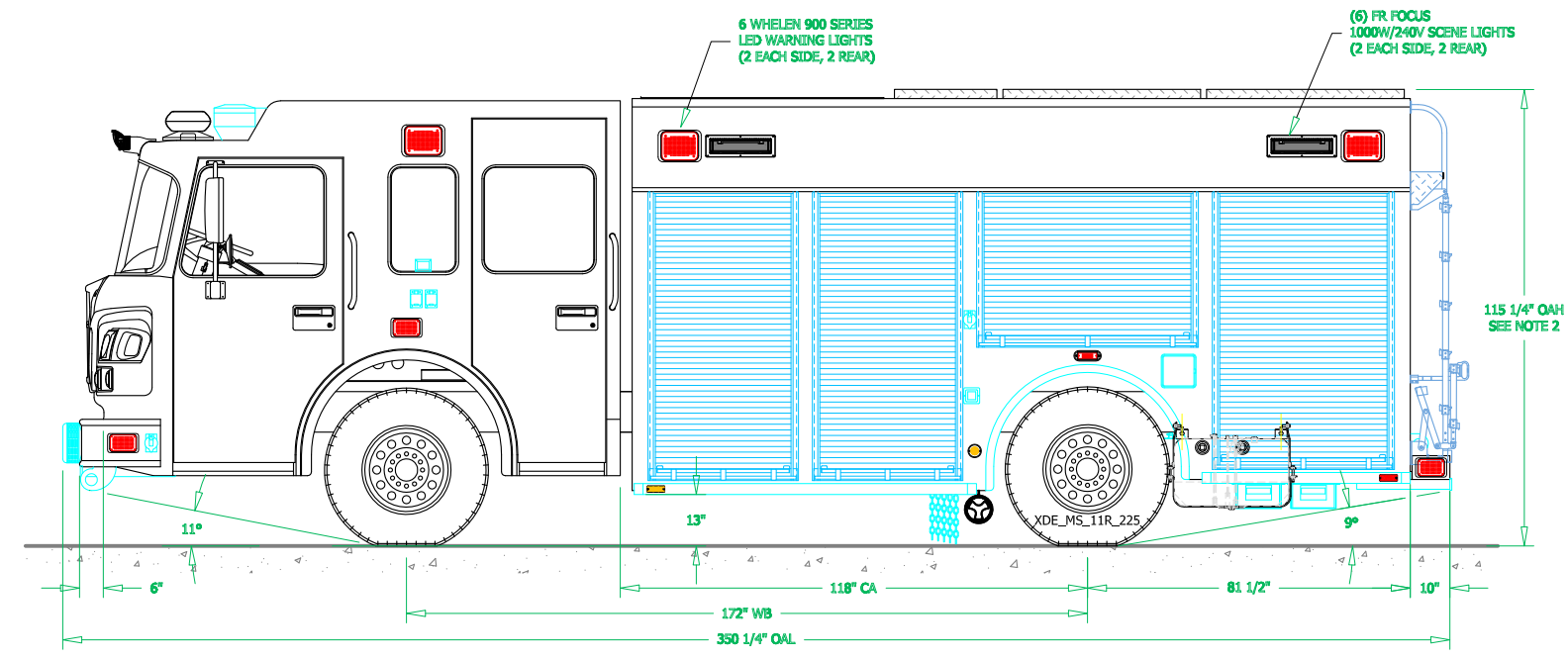
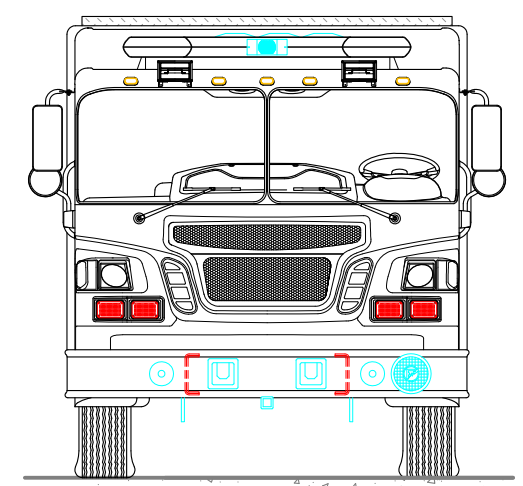
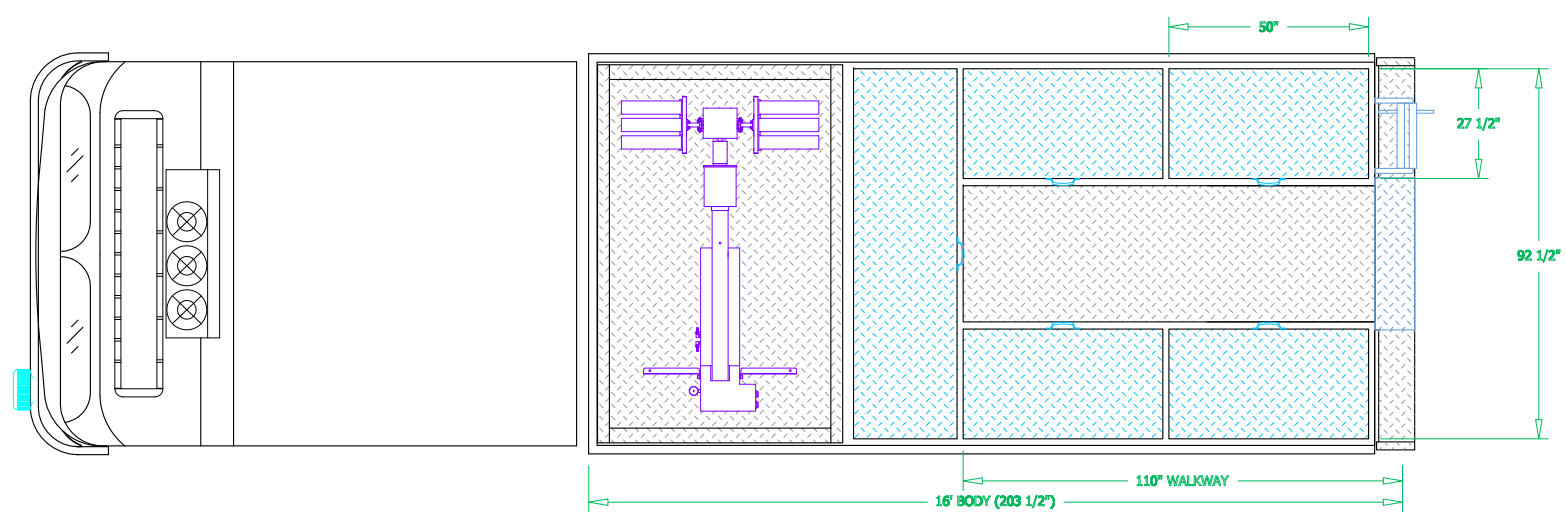

SVI FIRE & RESCUE TRUCKS
 1511 E. 11th STREET, LOVELAND, CO 80537 PHONE 970-667-5146, FAX 970-667-3343

**EAST GREAT PLAIN
 VOLUNTEER FIRE COMPANY**

BODY SIZE: 16' BODY	UNIT TYPE: HEAVY RESCUE
BODY MATERIAL: 3/16" ALUMINUM	TRUCK NO:
CHASSIS TYPE: SPARTAN	WHEELBASE: 172"
GLADIATOR MFD	CAB TO AXLE: 118"
4 DOOR	OVERALL LENGTH (OAL): 357 1/4"
10"RR	OVERALL WIDTH (OAW): 100"
	OVERALL HEIGHT (OAH): 117 1/4"

REVISIONS			
REV	DESCRIPTION	DATE	BY

NOTE 1: Do not scale drawing. This drawing is for general truck configuration only. All items and dimensions shown are approximate and may vary with final production. The drawing may not provide illustration for all items in the specification. In all situations where the drawing may contradict the specifications, the specifications shall prevail. This drawing and all data herein are provided as confidential materials and shall not be reproduced without written consent of the manufacturer.

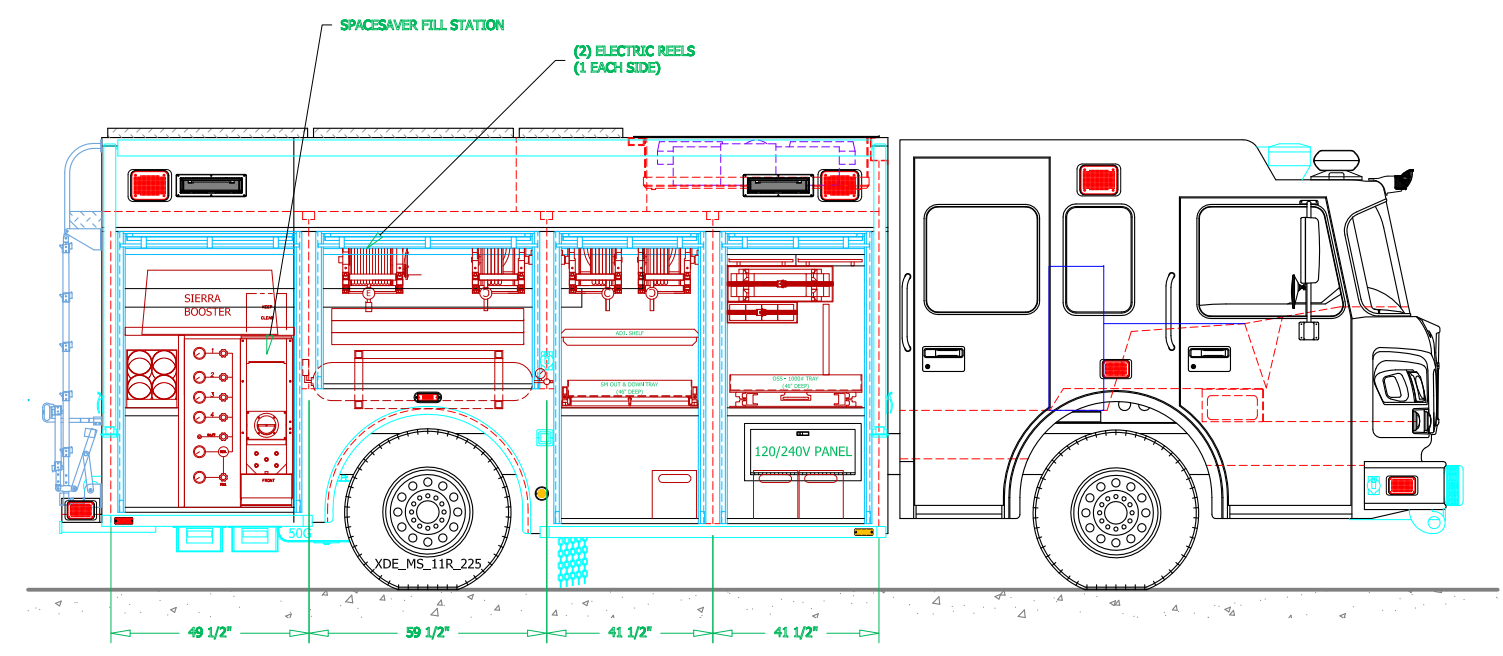
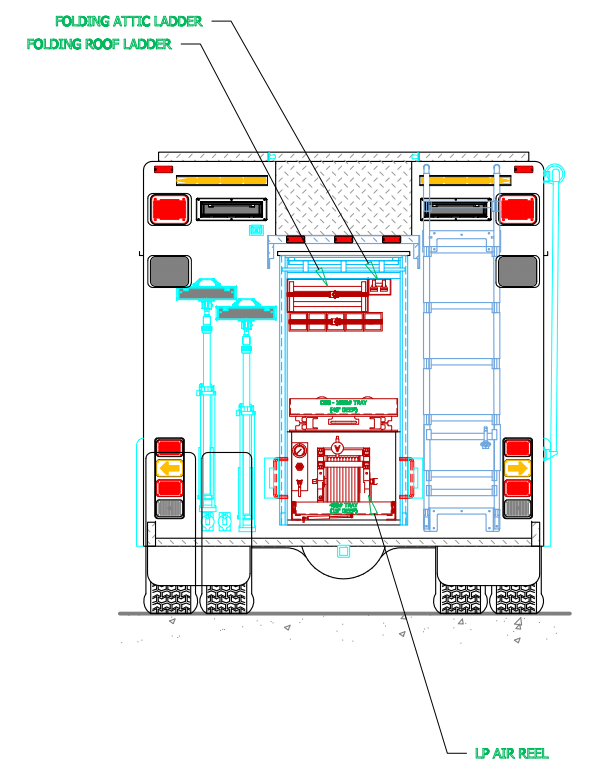
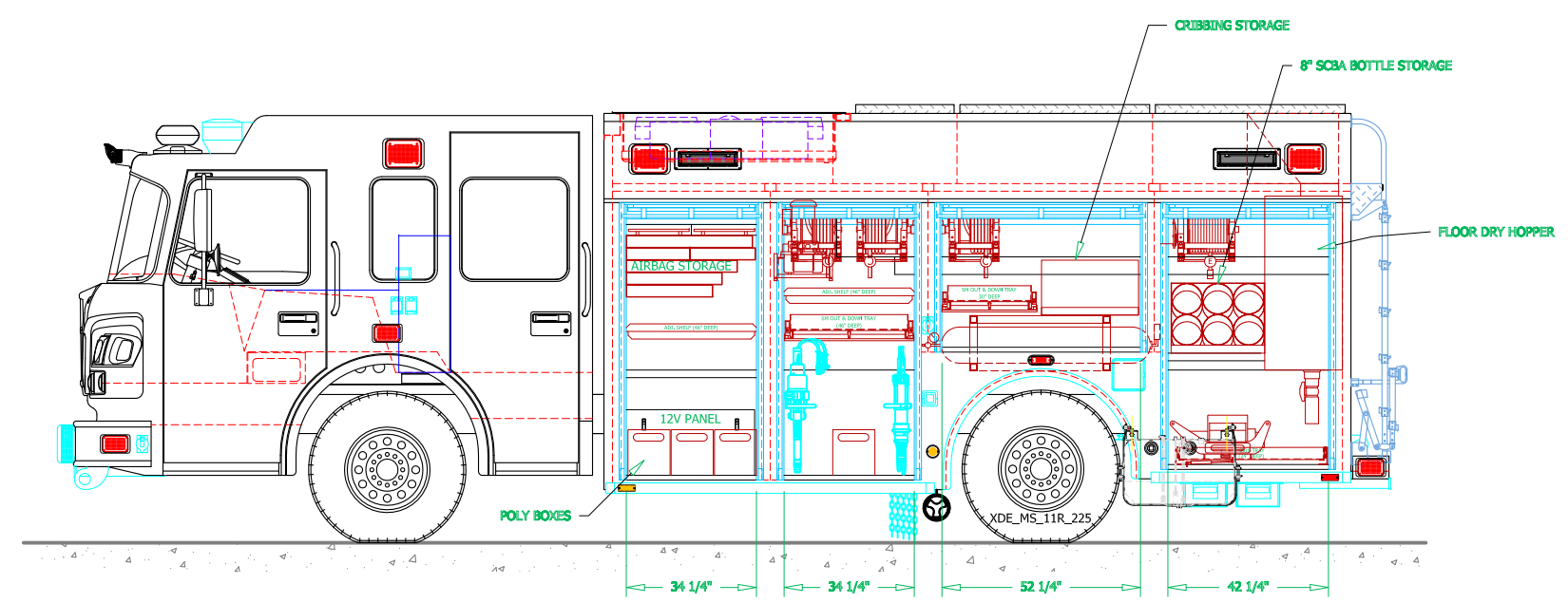
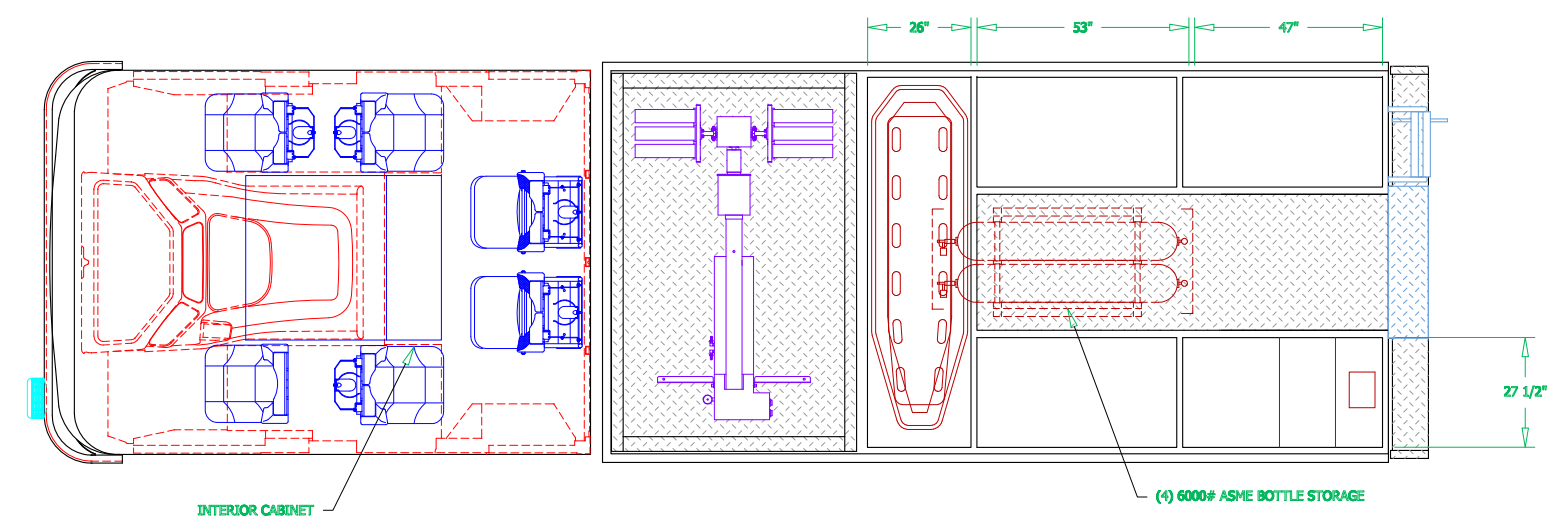



LOVELAND SVI COLORADO

SVI FIRE & RESCUE TRUCKS
1511 E. 11th STREET, LOVELAND, CO 80537 PHONE 970-667-5146, FAX 970-667-3343

**EAST GREAT PLAIN
VOLUNTEER FIRE COMPANY**

DRAWN BY: HJR	DATE: FEBRUARY 27, 2009	SCALE: 1/4" = 1' - 0"
DRAWING NO: EASTGREATPLAIN_CT_HR_16_PRECON_1.dwg		SHEET 2 OF 2