

PRECONSTRUCTION PROPOSAL DRAWING, CHANGES PENDING CHANGE ORDER

REVISIONS			
REV	DESCRIPTION	DATE	BY

NOTE 1: Do not scale drawing. This drawing is for general truck configuration only. All items and dimensions shown are approximate and may vary with final production. The drawing may not provide illustration for all items in the specification. In all situations where the drawing may contradict the specifications, the specifications shall prevail. This drawing and all data herein are provided as confidential materials and shall not be reproduced without written consent of the manufacturer.

NOTE 2: Chassis frame height will change due to axle characteristics, loading and the dimensions which will effect the overall height dimension shown. Any overall height restrictions should take this into consideration and allow approximately 2-3 inches of tolerance.

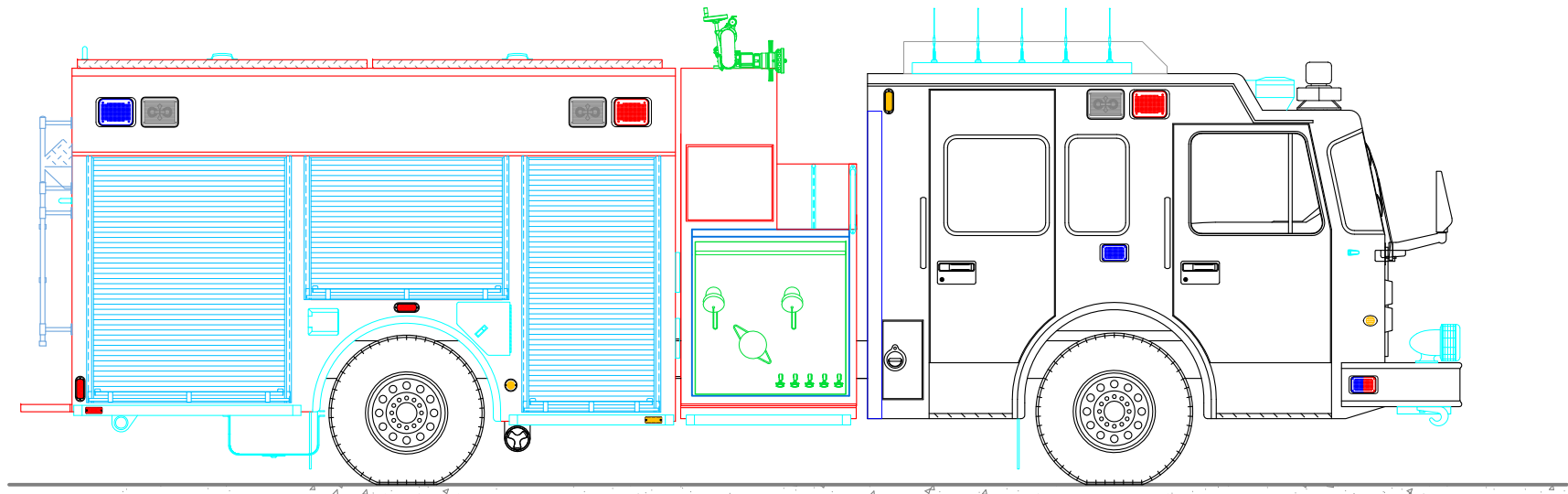
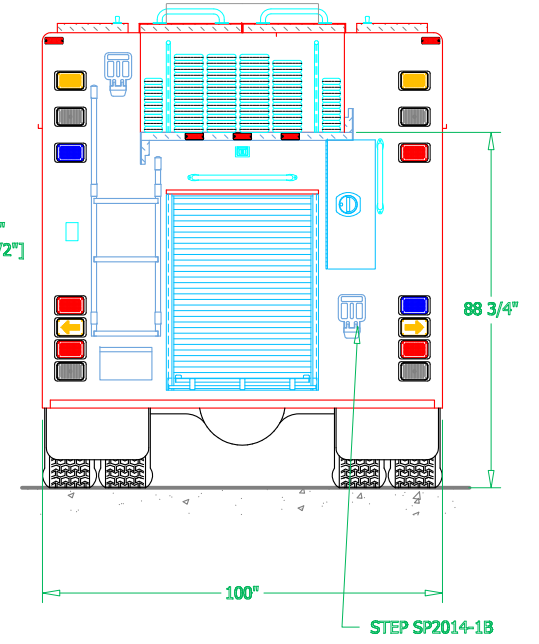
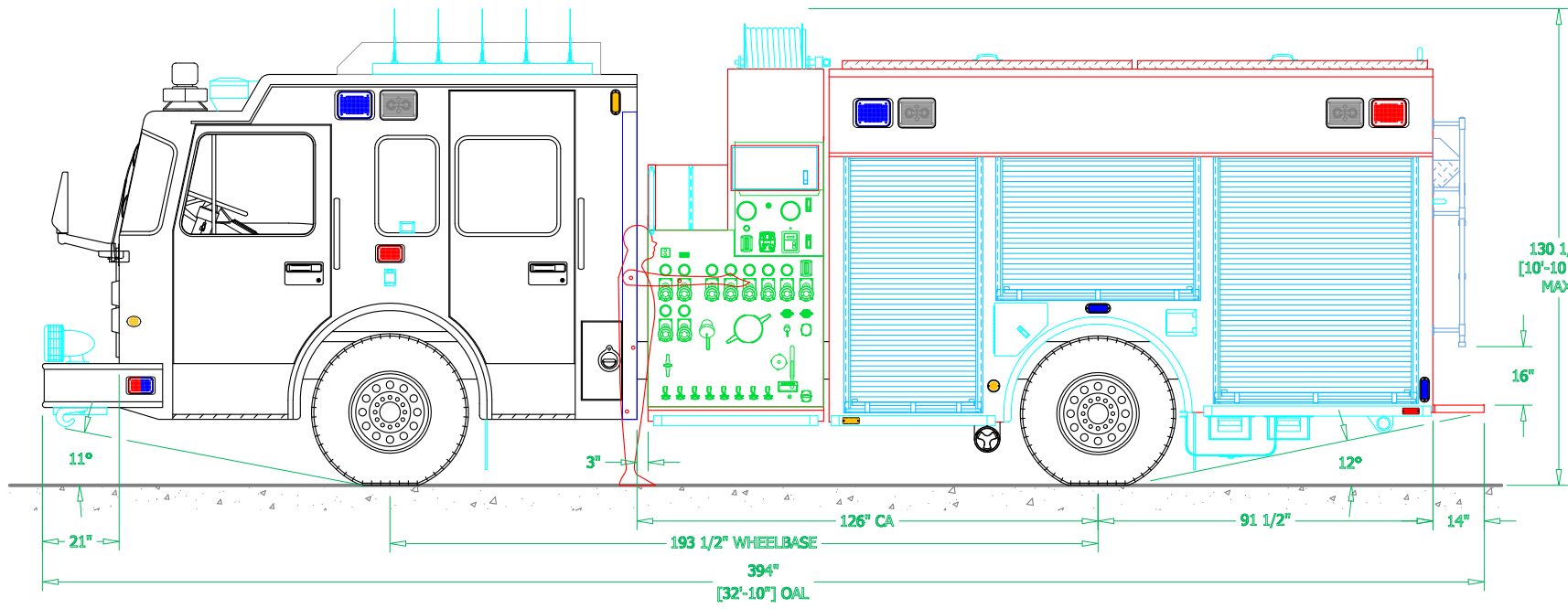
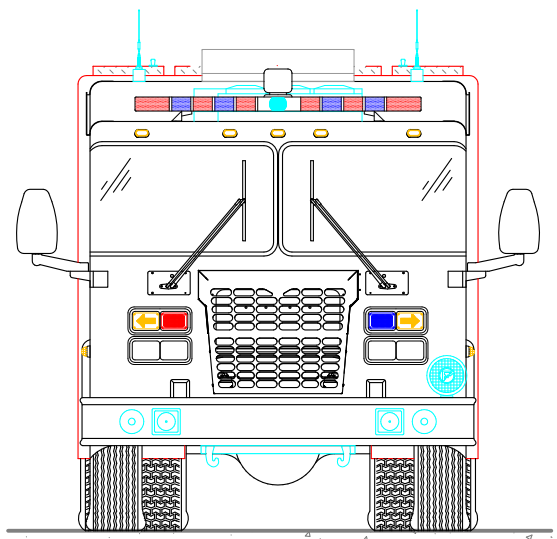
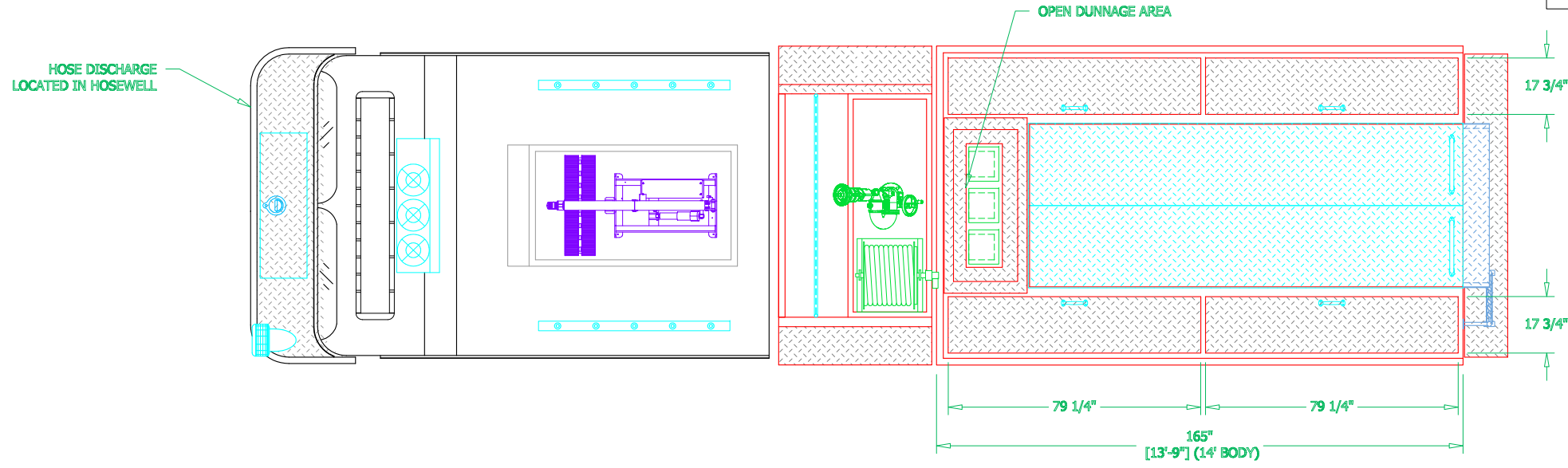

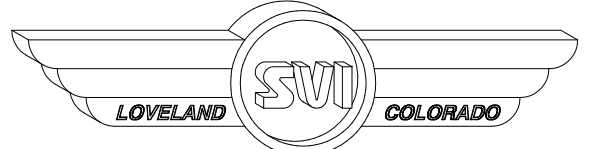

LOVELAND SVI COLORADO

SVI FIRE & RESCUE TRUCKS
1511 E. 11th STREET, LOVELAND, CO 80537 PHONE 970-667-5146, FAX 970-667-3343

SURPRISE FIRE DEPARTMENT

BODY SIZE: 14' BODY	UNIT TYPE: PUMPER
BODY MATERIAL: 3/16" ALUMINUM	TRUCK NO: SVI #xxx
CHASSIS TYPE: SPARTAN	WHEELBASE: SEE DWG
METRO STAR LFD	CAB TO AXLE: SEE DWG
10" RR	OVERALL LENGTH (OAL): SEE DWG
FOUR DOOR	OVERALL WIDTH (OAW): SEE DWG
	OVERALL HEIGHT (OAH): SEE DWG
DRAWN BY: HJR	DATE: December 21, 2016
DRAWING NO: Surprise_AZ_pm_PreCon2_964	SCALE: 1/4" = 1'-0"

SHEET 1 OF 2

PRELIMINARY DRAWING - FOR LAYOUT PURPOSES ONLY

REVISIONS			
REV	DESCRIPTION	DATE	BY

NOTE 1: Do not scale drawing. This drawing is for general truck configuration only. All items and dimensions shown are approximate and may vary with final production. The drawing may not provide illustration for all items in the specification. In all situations where the drawing may contradict the specifications, the specifications shall prevail. This drawing and all data herein are provided as confidential materials and shall not be reproduced without written consent of the manufacturer.

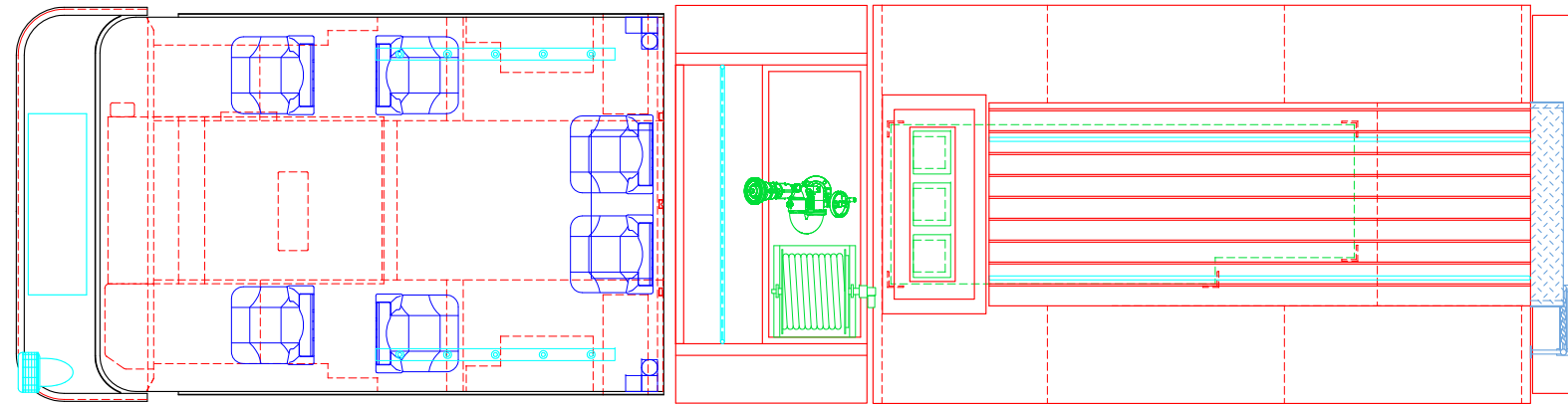

ENLARGED LADDER MODULE
SCALE: 1/2" = 1'-0"

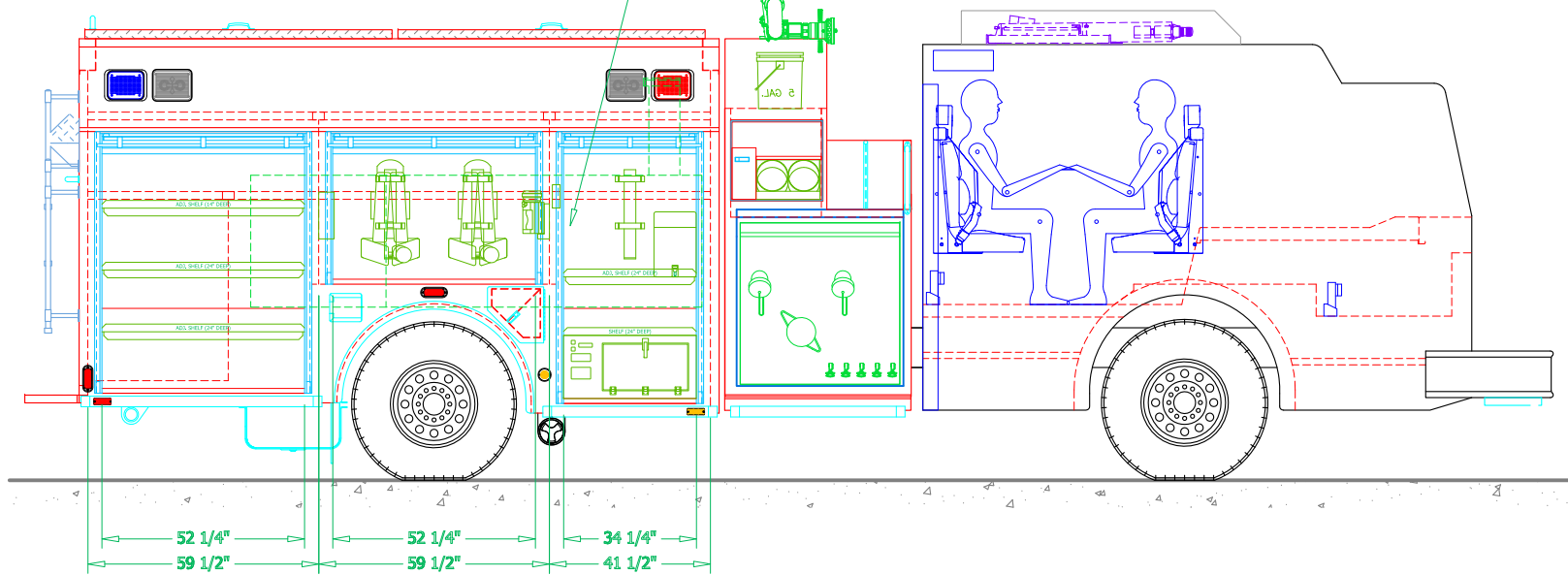
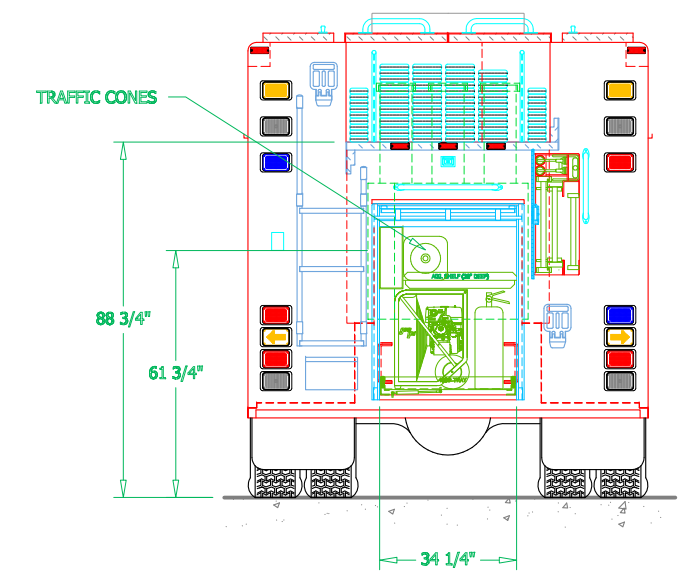
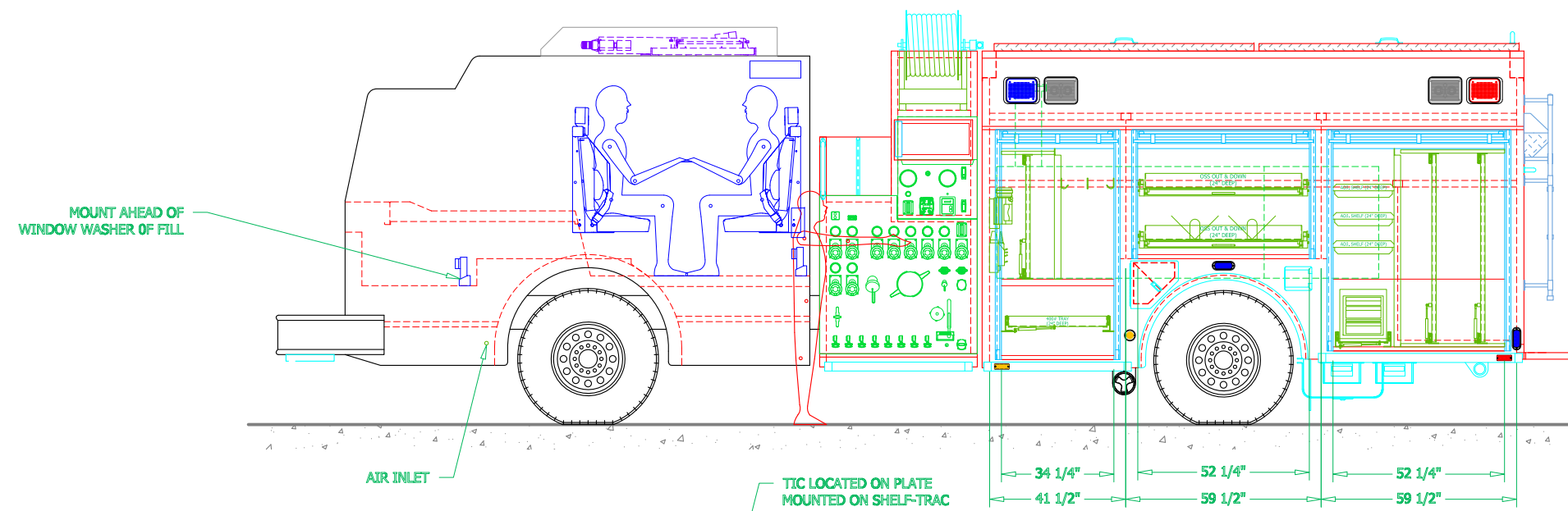
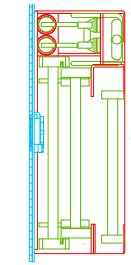



LOVELAND SVI COLORADO

SVI FIRE & RESCUE TRUCKS
1511 E. 11th STREET, LOVELAND, CO 80537 PHONE 970-667-5146, FAX 970-667-3343

**SURPRISE
FIRE DEPARTMENT**

DRAWN BY: HJR	DATE: December 21, 2016	SCALE: 1/4" = 1'-0"
DRAWING NO: Surprise_AZ_pm_PreCon2_964		SHEET 2 OF 2

PRECONSTRUCTION PROPOSAL DRAWING, CHANGES PENDING CHANGE ORDER

REVISIONS			
REV	DESCRIPTION	DATE	BY

NOTE 1: Do not scale drawing. This drawing is for general truck configuration only. All items and dimensions shown are approximate and may vary with final production. The drawing may not provide illustration for all items in the specification. In all situations where the drawing may contradict the specifications, the specifications shall prevail. This drawing and all data herein are provided as confidential materials and shall not be reproduced without written consent of the manufacturer.

NOTE 2: Chassis frame height will change due to axle characteristics, loading and the dimensions which will effect the overall height dimension shown. Any overall height restrictions should take this into consideration and allow approximately 2-3 inches of tolerance.

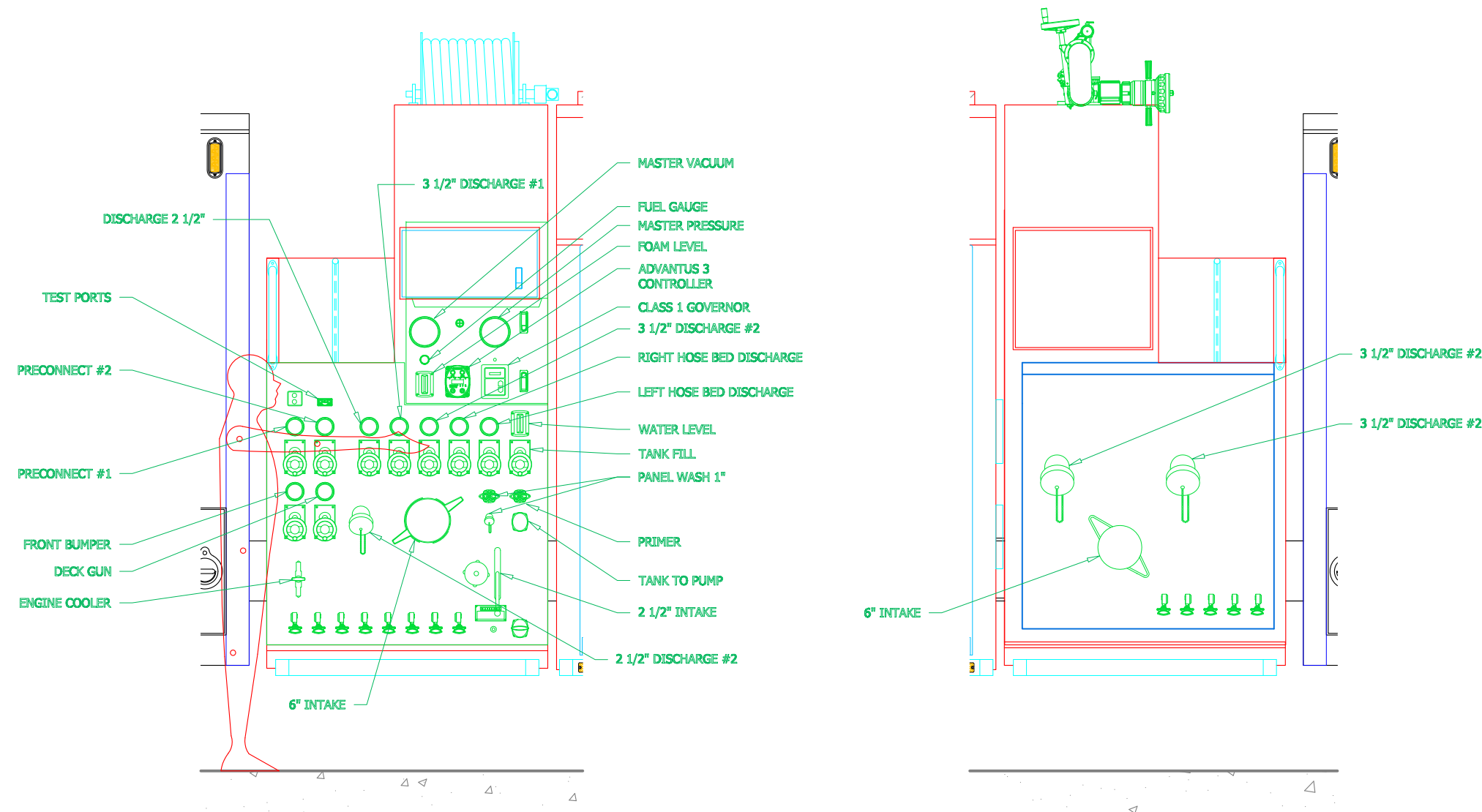

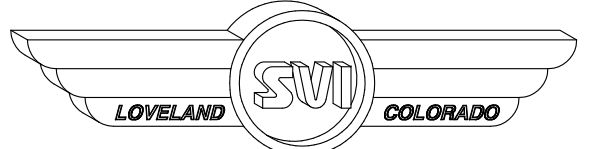

LOVELAND SVI COLORADO

SVI FIRE & RESCUE TRUCKS
1511 E. 11th STREET, LOVELAND, CO 80537 PHONE 970-667-5146, FAX 970-667-3343

**SURPRISE
FIRE DEPARTMENT**

BODY SIZE: 14' BODY	UNIT TYPE: PUMPER
BODY MATERIAL: 3/16" ALUMINUM	TRUCK NO: SVI #xxx
CHASSIS TYPE: SPARTAN	WHEELBASE: SEE DWG
METRO STAR LFD	CAB TO AXLE: SEE DWG
10" RR	OVERALL LENGTH (OAL): SEE DWG
FOUR DOOR	OVERALL WIDTH (OAW): SEE DWG
	OVERALL HEIGHT (OAH): SEE DWG

DRAWN BY: HJR DATE: December 21, 2016 SCALE: 1/2" = 1'-0"
DRAWING NO: Surprise_A7_pm_PreCon2_964 SHEET 1 OF 1