

**Houston Fire Department
Houston, TX
Haz-Mat SVI# 1237
Production Specification**



Copy of #1077 with Changes

TESTING

ROAD TEST

LOW VOLTAGE - ELECTRICAL SYSTEM PERFORMANCE TEST

UL 120/240 VAC CERTIFICATION

The 120/240 volt electrical system shall be third-party, independent, audit-certified through Underwriters Laboratory (UL) to the current edition of NFPA 1901 to perform as listed below;

DIELECTRIC VOLTAGE WITHSTAND TEST

The line voltage wiring and permanently connected devices and equipment shall be subjected to a dielectric voltage withstand test of 900 volts for one (1) minute. The testing shall be performed after all body work has been completed.

WARRANTY

A full statement shall be provided of the warranties for the vehicle(s) being bid. Warranties should clearly describe the terms under which the vehicle manufacturer accepts responsibility for the cost to repair defects caused by faulty design, quality of work or material and for the applicable period of time after delivery.

Cost of repairs refers to all costs related thereto including, but not limited to, the cost of materials and the cost of labor.

The Body Manufacturer shall warrant all materials and accessories used on the vehicle(s), whether fabricated by manufacturer or purchased from an outside source and will deal directly with the Houston Fire Department on all warranty work.

OVERALL HEIGHT REQUIREMENT

The overall height (OAH) of the vehicle shall be maximum 142" (11' - 10") from the ground. This measurement shall be taken on flat ground with the tires properly inflated, in the unloaded condition, at that highest point of the vehicle.

OVERALL LENGTH

The overall length (OAL) of the vehicle shall be approximately 456" (38' - 0").

OVERALL WIDTH

The overall width (OAW) of the body at drip rails shall be 102" (8' - 6"), and body shall be 100" (8' - 4").

ANGLE OF APPROACH

The angle of approach for this vehicle shall not be less than eight (8) degrees when it is loaded to the estimated in-service weight as specified by the current edition of NFPA 1901.

ANGLE OF DEPARTURE

The angle of departure for this vehicle shall not be less than eight (8) degrees when it is loaded to the estimated in-service weight as specified by the current edition of NFPA 1901.

CAB CHASSIS SPECIFICATION

MODEL

The chassis shall be a Gladiator model. The cab and chassis shall include design considerations for multiple emergency vehicle applications, rapid transit and maneuverability. The chassis shall be manufactured for heavy duty service with the strength and capacity to support a fully laden apparatus, one hundred (100) percent of the time.

MODEL YEAR

The chassis shall have a vehicle identification number that reflects a 2023 model year.

COUNTRY OF SERVICE

The chassis shall be put in service in the country of United States of America (USA).

The chassis will meet applicable U.S.A. federal motor vehicle safety standards per CFR Title 49 Chapter V Part 571 as clarified in the incomplete vehicle book per CFR Title 49 Chapter V Part 568 Section 4 which accompanies each chassis. The chassis manufacturer is not responsible for compliance to state, regional, or local regulations. Dealers should identify those regulations and order any necessary optional equipment from the chassis manufacturer or their OEM needed to be in compliance with those regulations.

CAB AND CHASSIS LABELING LANGUAGE

The cab and chassis shall include the applicable caution, warning, and safety notice labels with text to be written in English. All applicable caution, warning, and safety notice labels shall be Innovative Controls brand. Where applicable to the location within the specific layout and label package of the cab and chassis, the labels shall include decorative chrome bezels. Designs shall include bezels that fit individual labels or packaged configurations of labels in certain common locations.

The following labels shall be Innovative Controls brand, each including a decorative chrome bezel (where applicable):

- Shoreline
- Aerial Stowed
- Aerial Breakers 2
- Air Conditioner
- Cab Tilt Plate
- Air Compressor Breaker
- Battery Conditioner Breaker
- Helmet Caution
- Horn Tag
- Q2B Tag
- Load Center Plate
- Not a Step Label
- Occupancy Tag

- Do Not Move
- Occupants Must Be Seated
- Do Not Stand
- Danger Do Not Weld
- Danger--Untrained Operator
- DEF Fill Access (Including Additional 2907 Optional Labels)
- Battery Direct
- Kneeling
- IFS Air Fault
- Engine Brake
- Retarder
- LR 100 Amp Node
- 300 Amp EPU
- 100 Amp Front O/R Node
- 100 Amp T/T Node
- 100 Amp RR O/R Node
- 10 Amp EPU
- Master Power
- 12 Volt Power
- Aerial Hours
- Pump In Drive

Windshield Washer Fluid

APPARATUS TYPE

The apparatus shall be a rescue vehicle designed for emergency service use which shall include the functions of a multipurpose vehicle which primarily provides support services at emergency scenes.

VEHICLE TYPE

The chassis shall be manufactured for use as a straight truck type vehicle and designed for the installation of a permanently mounted apparatus behind the cab. The apparatus of the vehicle shall be supplied and installed by the apparatus manufacturer.

VEHICLE ANGLE OF APPROACH PACKAGE

The angle of approach of the apparatus shall be a minimum of 8.00 degrees.

NFPA1901 Angle of Approach definition:

“To determine the angle of approach, place a thin steel strip against the front of the tires where they touch the ground or stretch a tight string from one front tire to the other at the front where they touch the ground. Determine the lowest point (component or equipment) on the vehicle forward of the front tire that would make the smallest angle of approach. Hang a plumb bob from the lowest point and mark the point on the ground where the point of the plumb bob touches. Measure the vertical distance from the ground to the point where the plumb bob was hung (distance V). Measure the horizontal distance from the plumb bob point to the steel strip or string running from front tire to front tire (distance H). Divide the vertical distance by the horizontal distance. The ratio of V/H is the tangent of the angle of approach. If the ratio is known, the angle of approach can be determined from a table of trigonometric functions of angles or from a math calculator. The standard requires a minimum angle of approach of 8.00 degrees: since the tangent of 8.00 degrees is 0.1405, if V divided by H is 0.1405 or larger, the angle of approach is 8.00 degrees or greater.”

AXLE CONFIGURATION

The chassis shall feature a 4 x 2 axle configuration consisting of a single rear drive axle with a single front steer axle.

GROSS AXLE WEIGHT RATINGS FRONT

The front gross axle weight rating (GAWR) of the chassis shall be 22,800 pounds.

This front gross axle weight rating shall be adequate to carry the weight of the completed apparatus including all equipment and personnel.

GROSS AXLE WEIGHT RATINGS REAR

The rear gross axle weight rating (GAWR) of the chassis shall be 24,000 pounds.

This rear gross axle weight rating shall be adequate to carry the weight of the completed apparatus including all equipment and personnel.

CAB STYLE

The cab shall be a custom, fully enclosed, ELFD model with a 24.00 inch raised roof over the driver, officer, and crew area, designed and built specifically for use as an emergency response vehicle by a company specializing in cab and chassis design for all emergency response applications. The cab shall be designed for heavy-duty service utilizing superior strength and capacity for the application of protecting the occupants of the vehicle. This style of cab shall offer up to ten (10) seating positions.

The cab shall incorporate a fully enclosed design with side wall roof supports, allowing for a spacious cab area with no partition between the front and rear sections of the cab. To provide a superior finish by reducing welds that fatigue cab metal; the roof, the rear wall and side wall panels shall be assembled using a combination of welds and proven industrial adhesives designed specifically for aluminum fabrication for construction.

The cab shall be constructed using multiple aluminum extrusions in conjunction with aluminum plate, which shall provide proven strength and the truest, flattest body surfaces ensuring less expensive paint repairs if needed. All aluminum welding shall be completed to the American Welding Society and ANSI D1.2-96 requirements for structural welding of aluminum.

All interior and exterior seams shall be sealed for optimum noise reduction and to provide the most favorable efficiency for heating and cooling retention.

The cab shall be constructed of 5052-H32 corrosion resistant aluminum plate. The cab shall incorporate tongue and groove fitted 6061-T6 0.13 & 0.19 inch thick aluminum extrusions for extreme duty situations. A single formed, one (1) piece extrusion shall be used for the "A" pillar, adding strength and rigidity to the cab as well as additional roll-over protection. The cab side walls and lower roof skin shall be 0.13 inch thick; the rear wall and raised roof skins shall be 0.09 inch thick; the front cab structure shall be 0.19 inch thick.

The exterior width of the cab shall be 99.40 inches wide with a minimum interior width of 91.00 inches. The overall cab length shall be 151.10 inches with 74.00 inches from the centerline of the front of the axle to the back of the cab.

The cab interior shall be designed to afford the maximum usable interior space and attention to ergonomics with hip and legroom while seated which exceeds industry standards. The crew cab floor shall be flat across the entire walking area for ease of movement inside the cab.

The cab shall offer an interior height of 57.50 inches from the front floor to the headliner and a rear floor to headliner height of 79.00 inches in the raised roof area, at a minimum. The cab shall offer an interior measurement at the floor level from the rear of the engine tunnel to the rear wall of the cab of 69.88 inches. All interior measurements shall include the area within the interior trimmed surfaces and not to any unfinished surface.

The cab shall include a driver and officer area with two (2) cab doors large enough for personnel in full firefighting gear. The front doors shall offer a clear opening of 40.25 inches wide X 53.50 inches high, from the cab floor to the top of the door opening. The cab shall also include a crew area with up to two (2) cab doors, also large enough for personnel in full firefighting gear. The rear doors shall offer a clear opening of 32.25 inches wide X 71.00 inches high, from the cab floor to the top of the door opening.

The cab shall incorporate a progressive two (2) step configuration from the ground to the cab floor at each door opening. The progressive steps are vertically staggered and extend the full width of each step well allowing personnel in full firefighting gear to enter and exit the cab easily and safely.

The first step for the driver and officer area shall measure approximately 11.50 inches deep X 31.13 inches wide. The intermediate step shall measure approximately 8.50 inches deep X 32.50 inches wide. The height from the first step to the intermediate step and the intermediate step to the cab floor shall not exceed 11.00 inches.

The first step for the crew area shall measure approximately 11.50 inches deep X 20.44 inches wide. The intermediate step shall measure approximately 10.25 inches deep X 22.75 inches wide. The height from the first step to the intermediate step and the intermediate step to the cab floor shall not exceed 12.80 inches.

OCCUPANT PROTECTION

The vehicle shall include the Advanced Protection System™ (APS) which shall secure belted occupants and increase the survivable space within the cab. The APS shall selectively deploy integrated systems to protect against injuries in qualifying frontal impact, side impact, and rollover events. The increase in survivable space and security of the APS shall also provide ejection mitigation protection.

The system components shall include:

- Driver steering wheel airbag
- Driver dual knee air bags (patent pending) with energy management mounting (patent pending) and officer knee airbag.
- Large driver, officer, and crew area side curtain airbags
- APS advanced seat belt system - retractor pre-tensioners tighten the seat belts around the occupants, securing the occupants in seats and load limiters play out some of the seat belt webbing to reduce seat belt to chest and torso force upon impact as well as mitigate head and neck injuries
- Heavy truck Restraints Control Module (RCM) - receives inputs from the outboard sensors, selectively deploys APS systems, and records sensory inputs immediately before and during a detected qualifying event
- Integrated outboard crash sensors mounted at the perimeter of the vehicle - detects a qualifying front or side impact event and monitors and communicates vehicle status and real time diagnostics of all critical subsystems to the RCM
- Fault-indicating Supplemental Restraint System (SRS) light on the driver's instrument panel

Frontal impact protection shall be provided by the outboard sensors and the RCM. In a qualifying front impact event the outboard sensors provide inputs to the RCM. The RCM activates the steering wheel airbag, driver side dual knee airbags (patent pending), officer side knee airbag, and advanced seat belts for each occupant in the cab.

Rollover, side impact, and ejection mitigation shall be provided by the outboard sensors and the RCM. In qualifying rollover or side impact events the outboard sensors provide inputs to the RCM. The RCM activates the side curtain airbags and advanced seat belts for each occupant in the cab. The RCM measures roll angle, lateral acceleration, and roll rate to determine if a rollover event or side impact event is imminent or occurring.

In the event of a qualifying offset or other non-frontal impact, the RCM shall determine and intelligently deploy the front impact protection system, the side impact protection system, or both front and side impact protection systems based on the inputs received from the outboard crash sensors.

CAB FRONT FASCIA

The front cab fascia shall be constructed of 5052-H32 Marine Grade, 0.13 of an inch thick aluminum plate which shall be an integral part of the cab.

The cab fascia will encompass the entire front of the aluminum cab structure from the bottom of the windshield to the bottom of the cab and shall be the "Classic" design.

The front cab fascia shall include two (2) molded plastic modules on each side accommodating a total of up to four (4) Hi/Low beam headlights and two (2) turn signal lights or up to four (4) warning lights. A chrome plated molded plastic bezel shall be provided on each side around each set of four lamps.

FRONT GRILLE

The front cab fascia shall include a classic box style, 304 stainless steel front grille. The grille shall measure 55.45 wide X 33.50 inches high X 1.50 inches deep. The upper portion of the grille shall be hinged to provide service access behind the grille. The grille shall include a minimum free air intake of 750.00 square inches.

CAB UNDERCOAT

There shall be a rubberized undercoating applied to the underside of the cab that provides abrasion protection, sound deadening and corrosion protection.

CAB SIDE DRIP RAIL

There shall be a drip rail along the top radius of each cab side. The drip rails shall help prevent water from the cab roof running down the cab side.

CAB PAINT EXTERIOR

The cab shall be painted prior to the installation of glass accessories and all other cab trim to ensure complete paint coverage and the maximum in corrosion protection of all metal surfaces.

All metal surfaces on the entire cab shall be ground by disc to remove any surface oxidation or surface debris which may hinder the paint adhesion. Once the surface is machine ground a high quality acid etching of base primer shall be applied. Upon the application of body fillers and their preparation, the cab shall be primed with a coating designed for corrosion resistance and surface paint adhesion. The maximum thickness of the primer coat shall be 2.00 mils.

The entire cab shall then be coated with an intermediate solid or epoxy surfacing agent that is designed to fill any minor surface defects, provide an adhesive bond between the primer and the paint and improve the color and gloss retention of the color. The finish to this procedure shall be a sanding of the cab with 360 grit paper followed by sealing the seams with SEM brand seam sealer.

The cab shall then be painted the specific color designated by the customer with an acrylic urethane type system designed to retain color and resist acid rain and most atmospheric chemicals found on the fire ground or emergency scene. The paint shall have a minimum thickness of 2.00 mils, followed by a clear top coat not to exceed 2.00 mils. The entire cab shall then be baked at 180 degrees for one (1) hour to speed the curing process of the coatings.

CAB PAINT MANUFACTURER

The cab shall be painted with PPG Industries paint.

CAB PAINT PRIMARY/LOWER COLOR

The primary/lower paint color shall be PPG FBCH 926236 red.

CAB PAINT WARRANTY

Purchaser shall receive a Paint and Finish (Exterior Clear coated) Seven (7) Years limited warranty in accordance with, and subject to, warranty certificate RFW0707. The warranty certificate is incorporated by reference into this proposal, and included with this proposal or available upon request.

CAB INTERIOR/COMPONENT COATING

All visible cab structure surfaces and painted interior components shall be manually selected at each interior component's sub category.

CAB PAINT INTERIOR

The visible interior cab structure surfaces shall feature a dark red spray on bedliner coating which shall mold to each surface of the cab interior. The bedliner shall be environmentally friendly and chemically resistant.

CAB ENTRY DOORS

The cab shall include three (3) entry doors, two (2) front doors and one (1) crew on the right side of the cab designed for ease of entering and egress when outfitted with an SCBA. The doors shall be constructed of extruded aluminum with a nominal thickness of 0.13 inch. The exterior skins shall be constructed of 0.13 inch aluminum plate.

The doors shall include a double rolled style automotive rubber seal around the perimeter of each door frame and door edge which ensures a weather tight fit.

All door hinges shall be hidden within flush mounted cab doors for a pleasing smooth appearance and perfect fit along each side of the cab. Each door hinge shall be piano style with a 0.38 inch pin and shall be constructed of stainless steel.

CAB ENTRY DOOR TYPE

All cab entry doors shall be barrier clear design resulting in exposed lower cab steps. The doors shall provide approximately 32.00 inches of clearance from the ground to the bottom of the door so cab doors may be opened unhindered by most obstacles encountered, such as guard rails along interstate highways.

Entry doors shall include Pollak mechanical plunger style switches for electrical component activation.

CAB INSULATION

The cab ceiling and walls shall include a nonwoven polyester fiber insulation. The insulation shall act as a barrier absorbing noise as well as assisting in sustaining the desired climate within the cab interior.

LH MID EMS COMPARTMENT

The cab shall include an interior clear area provision for the side curtain crew airbag mounting to account for a compartment located in the middle of the wall to be installed by the body builder. The clear area shall extend from the cab 'B' pillar to the standard rear door location above the left side wheel well. The provision allows appropriate airbag selection for clear airbag deployment and adequate protection and ejection mitigation.

RH MID EMS COMPARTMENT

The cab shall include an interior clear area provision for the side curtain crew airbag mounting to account for a compartment located in the middle of the wall to be installed by the body builder. The clear area shall extend from the cab 'B' pillar to the standard rear door location above the right side wheel well. The provision allows appropriate airbag selection for clear airbag deployment and adequate protection and ejection mitigation.

CAB STRUCTURAL WARRANTY

Purchaser shall receive a Cab Structure (Aluminum) Ten (10) Years or 100,000 Miles limited warranty in accordance with, and subject to, warranty certificate RFW0602. The warranty certificate is incorporated by reference into this proposal, and included with this proposal or available upon request.

CAB TEST INFORMATION

The cab shall have successfully completed the preload side impact, static roof load application and frontal impact without encroachment to the occupant survival space when tested in accordance with Section 4 of SAE J2420 COE Frontal Strength Evaluation Dynamic Loading Heavy Trucks, Section 5 of SAE J2422 Cab Roof Strength Evaluation Quasi –Static Loading Heavy Trucks and ECE R29 Uniform Provisions Concerning the Approval of Vehicles with regard to the Protection of the Occupants of the Cab of a Commercial Vehicles Annex 3 Paragraph 5.

The above tests have been witnessed by and attested to by an independent third party. The test results were recorded using cameras, high speed imagers, accelerometers and strain gauges. Documentation of the testing shall be provided upon request.

ELECTRICAL SYSTEM

The chassis shall include a single starting electrical system which shall include a 12 volt direct current multiplexing system, suppressed per SAE J551. The wiring shall be appropriate gauge cross link with 311 degree Fahrenheit insulation. All SAE wires in the chassis shall be color coded and shall include the circuit number and function where possible. The wiring shall be protected by 275 degree Fahrenheit minimum high temperature flame retardant loom. All nodes and sealed Deutsch connectors shall be waterproof.

MULTIPLEX DISPLAY

The multiplex electrical system shall include a Weldon Vista IV display which shall be located on the left side of the dash in the switch panel. The Vista IV shall feature a full color LCD display screen which includes a message bar displaying the time of day and important messages requiring acknowledgement by the user which shall all be displayed on the top of the screen in the order they are received. There shall be eight (8) push button virtual controls, four (4) on each side of the display for the on-board diagnostics. The display screen shall be video ready for back-up cameras, thermal cameras, and DVD.

The Vista IV display shall offer varying fonts and background colors. The display shall be fully programmable to the needs of the customer and shall offer virtually infinite flexibility for screen configuration options.

MULTIPLEX DISPLAY SPECIAL LAYOUT

The Vista display and control screen shall be configured specifically for a virtual button on the control screen to override the park brake interlocked deactivation of the wiper system. This will reset when the park brake is cycled.

LOAD MANAGEMENT SYSTEM

The apparatus load management shall be performed by the included multiplex system. The multiplex system shall also feature the priority of sequences and shall shed electrical loads based on the priority list specifically programmed.

DATA RECORDING SYSTEM

The chassis shall have a Weldon Vehicle Data Recorder (VDR) system installed. The system shall be designed to meet NFPA 1901 and shall be integrated with the Weldon Multiplex electrical system. The following information shall be recorded:

- Vehicle Speed
- Acceleration
- Deceleration
- Engine Speed
- Engine Throttle Position
- ABS Event
- Seat Occupied Status
- Seat Belt Status
- Master Optical Warning Device Switch Position
- Time
- Date

Each portion of the data shall be recorded at the specified intervals and stored for the specified length of time to meet NFPA 1901 guidelines and shall be retrievable by connecting a laptop computer to the VDR system. The laptop connection shall be a panel mounted female type B USB connection point, remotely mounted in the left side foot well.

ACCESSORY POWER

The electrical distribution panel shall include two (2) power studs. The studs shall be size #10 and each of the power studs shall be circuit protected with a fuse of the specified amperage. One (1) power stud shall be capable of carrying up to a 40 amp battery direct load. One (1) power stud shall be capable of carrying up to a 15 amp ignition switched load. The two (2) power studs shall share one (1) #10 ground stud. A 225 amp battery direct power and ground stud shall be provided and installed on the chassis near the left hand battery box for OEM body connections.

EXTERIOR ELECTRICAL TERMINAL COATING

All terminals exposed to the elements will be sprayed with a high visibility protective rubberized coating to prevent corrosion.

ELECTRICAL SYSTEM WARRANTY

Purchaser shall receive an Electrical System Two (2) Years or 36,000 Miles limited warranty in accordance with, and subject to, warranty certificate RFW0202. The warranty certificate is incorporated by reference into this proposal, and included with this proposal or available upon request.

ENGINE

The chassis engine shall be a Cummins X15 engine. The X15 engine shall be an in-line six (6) cylinder, four cycle diesel powered engine. The engine shall offer a rating of 565 horse power at 1800 RPM and shall be governed at 2100 RPM. The torque rating shall feature 1850 foot pounds of torque at 1000 RPM with 912 cubic inches (14.9 liter) of displacement.

The X15 engine shall feature a VGT™ Turbocharger, a high pressure common rail fuel system, fully integrated electronic controls with an electronic governor, and shall be EPA certified to meet the 2021 emissions standards using cooled exhaust gas recirculation and selective catalytic reduction technology.

The engine shall include an engine mounted combination full flow/by-pass oil filter with replaceable spin on cartridge for use with the engine lubrication system. The engine shall include Citgo brand Citgard 500, or equivalent 15W40 CK-4 low ash engine oil which shall be utilized for proper engine lubrication.

A wiring harness shall be supplied ending at the back of the cab. The harness shall include a connector which shall allow an optional harness for the pump panel. The included circuits shall be provided for a tachometer, oil pressure, engine temperature, hand throttle, high idle and a PSG system. A circuit for J1939 data link shall also be provided at the back of the cab.

CAB ENGINE TUNNEL

The cab interior shall include an integrated engine tunnel constructed of 5052-H32 Marine Grade 0.19 of an inch thick aluminum alloy plate. The tunnel shall be a maximum of 46.50 inches wide X 29.00 inches high.

DIESEL PARTICULATE FILTER CONTROLS

There shall be two (2) controls for the diesel particulate filter. One (1) control shall be for regeneration and one (1) control shall be for regeneration inhibit.

ENGINE PROGRAMMING HIGH IDLE SPEED

The engine high idle control shall maintain the engine idle at approximately 1250 RPM when engaged.

ENGINE HIGH IDLE CONTROL

The vehicle shall be equipped with a virtual Vista button and an automatic high-idle speed control. It shall be pre-set so when activated, it will operate the engine at the appropriate RPM to increase alternator output. This device shall operate only when the engine is running and the transmission is in neutral with the parking brake set. The device shall disengage when the operator depresses the brake pedal, or the transmission is placed in gear, and shall be available to manually or automatically re-engage when the brake is released, or when the transmission is placed in neutral. There shall be an indicator on the Vista display and control screen for the high idle speed control.

ENGINE PROGRAMMING ROAD SPEED GOVERNOR

The engine shall include programming which will govern the top speed of the vehicle.

AUXILIARY ENGINE BRAKE

A compression brake, for the six (6) cylinder engine shall be provided. A cutout relay shall be installed to disable the compression brake when in pump mode or when an ABS event occurs. The engine compression brake shall activate upon 0% accelerator when in operation mode and actuate the vehicle's brake lights.

The engine shall utilize a variable geometry turbo (VGT) as an integrated auxiliary engine brake to offer a variable rate of exhaust flow, which when activated in conjunction with the compression brake shall enhance the engine's compression braking capabilities.

AUXILIARY ENGINE BRAKE CONTROL

An engine compression brake control device shall be included. The electronic control device shall monitor various conditions and shall activate the engine brake only if all of the following conditions are simultaneously detected:

- A valid gear ratio is detected.
- The driver has requested or enabled engine compression brake operation.
- The throttle is at a minimum engine speed position.
- The electronic controller is not presently attempting to execute an electronically controlled final drive gear shift.

The compression brake shall be controlled via an off/low/high virtual button through the Vista display and control screen. The multiplex system shall remember and default to the last engine brake control setting when the vehicle is shut off and re-started.

FLUID FILLS

The front of the chassis shall accommodate fluid fill for the engine oil through the grille. This area shall also accommodate a check for the engine oil. The transmission, power steering, and coolant fluid fills and checks shall be under the cab. The windshield washer fill shall be accessible through the front left side mid step.

ENGINE DRAIN PLUG

The engine shall include an original equipment manufacturer installed oil drain plug.

ENGINE WARRANTY

The Cummins engine shall be warranted for a period of five (5) years or 100,000 miles, whichever occurs first.

ENGINE PROGRAMMING REMOTE THROTTLE

The engine ECM (Electronic Control Module) discreet wire remote throttle circuit shall be turned off for use with a J1939 based pump controller or when the discreet wire remote throttle controls are not required.

ENGINE PROGRAMMING IDLE SPEED

The engine low idle speed will be programmed at 700 rpm.

ENGINE AIR INTAKE

The engine air intake system shall include an ember separator. This ember separator shall be designed to protect the downstream air filter from embers using a combination of unique flat and crimped metal screens packaged in a heavy duty galvanized steel frame. This multilayered screen shall trap embers and allow them to burn out before passing through the pack.

The engine air intake system shall also include an air cleaner mounted above the radiator. This air cleaner shall utilize a replaceable dry type filter element designed to prevent dust and debris from being ingested into the engine. A service cover shall be provided on the housing, reducing the chance of contaminating the air intake system during air filter service.

The air intake system shall include a restriction indicator light in the warning light cluster on the instrument panel, which shall activate when the air cleaner element requires replacement.

ENGINE FAN DRIVE

The engine cooling system fan shall incorporate a thermostatically controlled, Horton fully variable type fan drive with SmartClutch J-1939 CAN controller.

The variable speed fan clutch only engages at the amount needed for proper cooling to facilitate improved vehicle performance, cab heating in cold climates, and fuel economy. The fan clutch design shall be fail-safe so that if the clutch drive fails the fan shall engage to prevent engine overheating due to the fan clutch failure. The fan speed shall include a J-1939 CAN clutch controller to receive signal from the engine control module to activate at variable rates of speed. Variable speeds shall be set through thermostatic and engine speed signals to run as efficiently and quietly as required to maintain temperature.

ENGINE COOLING SYSTEM

There shall be a heavy-duty aluminum cooling system designed to meet the demands of the emergency response industry. The cooling system shall have the capacity to keep the engine properly cooled under all conditions of road and pumping operations. The cooling system shall be designed and tested to meet or exceed the requirements specified by the engine and transmission manufacturer and all EPA requirements. The complete cooling system shall be mounted to isolate the entire system from vibration or stress. The individual cores of the cooling system shall be mounted in a manner to allow expansion and contraction at various rates without inducing stress into the adjoining cores.

The cooling system shall be comprised of a charge air cooler to radiator serial flow package that provides the maximum cooling capacity for the specified engine as well as serviceability. The main components shall include a surge tank, a charge air cooler bolted to the front of the radiator, recirculation shields, a shroud, a fan, and required tubing.

The radiator shall be a down-flow design constructed with aluminum cores, plastic end tanks, and a steel frame. The radiator shall be equipped with a drain cock to drain the coolant for serviceability.

The cooling system shall include a one piece injected molded polymer fan with a three (3) piece fiberglass fan shroud.

The cooling system shall be equipped with a surge tank that is capable of removing entrained air from the system. The surge tank shall be equipped with a low coolant probe and rearward oriented sight glass to observe coolant in the system. A cold fill and observation line shall be included within the frame mounted translucent recovery bottle to monitor the level of the coolant. The surge tank shall have a dual seal cap that meets the engine manufacturer's pressure requirements and allows for expansion and recovery of coolant into a separate integral expansion chamber.

All radiator tubes shall be formed from aluminized steel tubing. Recirculation shields shall be installed where required to prevent heated air from reentering the cooling package and affecting performance.

The charge air cooler shall be a cross-flow design constructed completely of aluminum with cast tanks. All charge air cooler tubes shall be formed from aluminized steel tubing and installed with silicone hump hoses and stainless steel "constant torque" style clamps meeting the engine manufacturer's requirements.

The radiator and charge air cooler shall be removable through the bottom of the chassis.

ENGINE COOLING SYSTEM PROTECTION

The engine cooling system shall include a recirculation shield designed to act as a light duty skid plate below the radiator to provide additional protection for the engine cooling system from light impacts, stones, and road debris. The skid plate shall be painted to match the frame components.

ENGINE COOLANT

The cooling package shall include Extended Life Coolant (ELC). The use of ELC provides longer intervals between coolant changes over standard coolants providing improved performance. The coolant shall contain a 50/50 mix of ethylene glycol and de-ionized water to keep the coolant from freezing to a temperature of -34 degrees Fahrenheit.

Proposals offering supplemental coolant additives (SCA) shall not be considered, as this is part of the extended life coolant makeup.

ENGINE COOLANT FILTER

An engine coolant filter with a shut-off valve for the inlet and outlet shall be installed on the chassis. The location of the filter shall allow for easy maintenance.

Proposals offering engines equipped with coolant filters shall be supplied with standard non-chemical type particulate filters.

ELECTRONIC COOLANT LEVEL INDICATOR

The instrument panel shall feature a low engine coolant indicator light which shall be located in the center of the instrument panel. An audible tone alarm shall also be provided to warn of a low coolant incident.

COOLANT HOSES

The cooling systems hose shall be formed silicone hose and formed aluminized steel tubing and include stainless steel constant torque band clamps.

ENGINE COOLANT OVERFLOW BOTTLE

A remote engine coolant overflow expansion bottle shall be provided in the case of over filling the coolant system. The overflow bottle shall capture the expansion fluid or overfill rather than allow the fluid to drain on the ground.

ENGINE EXHAUST SYSTEM

The exhaust system shall include an end-in end-out horizontally mounted single module after treatment device, and downpipe from the charge air cooled turbo. The single module shall include four temperature sensors, diesel particulate filter (DPF), urea dosing module (UL2), and a selective catalytic reduction (SCR) catalyst to meet current EPA standards. The selective catalytic reduction catalyst utilizes a diesel exhaust fluid solution consisting of urea and purified water to convert NOx into nitrogen, water, and trace amounts of carbon dioxide. The solution shall be mixed and injected into the system through the DPF and SCR.

The system shall utilize 0.07 inch thick stainless steel exhaust tubing between the engine turbo and the DPF. Zero leak clamps seal all system joints between the turbo and DPF.

The single module after treatment through the end of the tailpipe shall be connected with zero leak clamps. The discharge shall terminate horizontally on the left side of the vehicle ahead of the rear tires.

The exhaust system after treatment module shall be mounted below the frame in the inboard position.

DIESEL EXHAUST FLUID TANK

The exhaust system shall include a molded cross linked polyethylene tank for Diesel Exhaust Fluid (DEF). The tank shall have a capacity of six (6) usable gallons and shall be mounted on the left hand side of the chassis frame behind the batteries below the frame.

The DEF tank shall be designed with capacity for expansion in case of fluid freezing. Engine coolant, which shall be thermostatically controlled, shall be run through lines in the tank to help prevent the DEF from freezing and to provide a means of thawing the fluid if it should become frozen.

The tank fill tube shall be routed under the rear of the cab with the fill neck and splash guard accessible through the lower left side of the three (3) door cab.

ENGINE EXHAUST ACCESSORIES

An exhaust temperature mitigation device shall be shipped loose for installation by the body manufacturer on the vehicle. The temperature mitigation device shall lower the temperature of the exhaust by combining ambient air with the exhaust gasses at the exhaust outlet.

ENGINE EXHAUST WRAP

The exhaust tubing between the engine turbo and the diesel particulate filter (DPF) shall be wrapped with a thermal cover in order to retain the necessary heat for DPF regeneration. The exhaust wrap shall also help protect surrounding components from radiant heat which can be transferred from the exhaust.

The exhaust flex joint shall not include the thermal exhaust wrap.

EMISSIONS SYSTEMS WARRANTY

Purchaser shall receive a Regulated Emissions Systems Five (5) Years or 100,000 Miles limited warranty in accordance with, and subject to, warranty certificate RFW0140. The warranty certificate is incorporated by reference into this proposal, and included with this proposal or available upon request.

TRANSMISSION

The drive train shall include an Allison model EVS 4000 torque converting, automatic transmission which shall include electronic controls and an output retarder. The transmission shall feature two (2) 10-bolt PTO pads located on the converter housing.

The transmission shall include two (2) internal oil filters which shall offer Castrol TranSynd™ synthetic TES 295 transmission fluid which shall be utilized in the lubrication of the EVS transmission. An electronic oil level sensor shall be included with the readout located in the shift selector.

The transmission gear ratios shall be:

1st	3.51:1
2nd	1.91:1
3rd	1.43:1
4th	1.00:1
5th	0.74:1
6th	0.64:1 (if applicable)
Rev	4.80:1

TRANSMISSION MODE PROGRAMMING

The transmission, upon start-up, will select a six (6) speed operation without the need to press the mode button.

TRANSMISSION FEATURE PROGRAMMING

The Allison Gen V/VI-E transmission EVS group package number 127 shall contain the 227 vocational package in consideration of the duty of this apparatus for rescue. This package shall incorporate an automatic neutral with selector override. This feature commands the transmission to neutral when the park brake is applied, regardless of drive range requested on the shift selector. This requires re-selecting drive range to shift out of neutral for the override.

A transmission interface connector shall be provided in the cab. This package shall contain the following input/output circuits to the transmission control module. The Gen V/VI-E transmission shall include prognostic diagnostic capabilities. These capabilities shall include the monitoring of the fluid life, filter change indication, and transmission clutch maintenance.

<u>Function ID</u>	<u>Description</u>	<u>Wire assignment</u>
Inputs		
C	PTO Request	143
F	Aux. Function Range Inhibit (Special)	101/142
Outputs		
G	PTO Enable Output (See Input Function C)	130
S	Neutral Indicator for PTO	145
	Signal Return	103

ELECTRONIC TRANSMISSION OIL LEVEL INDICATOR

The transmission fluid shall be monitored electronically and shall send a signal to activate a warning in the instrument panel when levels fall below normal.

TRANSMISSION SHIFT SELECTOR

An Allison pressure sensitive range selector touch pad shall be provided and located to the right of the driver within clear view and easy reach. The shift selector shall have a graphical Vacuum Florescent Display (VFD) capable of displaying two lines of text. The shift selector shall provide mode indication and a prognostic indicator (wrench symbol) on the digital display. The prognostics monitor various operating parameters and shall alert you when a specific maintenance function is required.

TRANSMISSION RETARDER CONTROL

The Allison transmission retarder shall be engaged with the first one-third at 0% throttle and the remaining two-thirds shall be modulated by brake pedal actuation. The system shall include a retarder on/off virtual button on the Vista display and control screen. The engagement of the retarder shall activate the brake lights. The retarder shall be inactive during pump mode.

TRANSMISSION RETARDER CAPACITY LEVEL

The transmission retarder shall be programmed so the maximum retardation shall be at the high capacity level.

TRANSMISSION PRE-SELECT WITH AUXILIARY BRAKE

When the auxiliary brake is engaged, the transmission shall automatically shift to second gear to decrease the rate of speed assisting the secondary braking system and slowing the vehicle.

TRANSMISSION COOLING SYSTEM

The transmission shall include a water to oil cooler system located in the cooling loop between the radiator and the engine. The transmission cooling system shall meet all transmission manufacturer requirements. The transmission cooling system shall feature continuous flow of engine bypass water to maintain uninterrupted transmission cooling.

TRANSMISSION DRAIN PLUG

The transmission shall include an original equipment manufacturer installed magnetic transmission fluid drain plug.

TRANSMISSION WARRANTY

The Allison EVS series transmission shall be warranted for a period of five (5) years with unlimited mileage. Parts and labor shall be included in the warranty.

PTO LOCATION

The transmission shall have two (2) power take off (PTO) mounting locations, one (1) in the 8:00 o'clock position and one (1) in the 1:00 o'clock position.

DRIVELINE

All drivelines shall be heavy duty metal tube and equipped with Spicer 1810 series universal joints. The shafts shall be dynamically balanced prior to installation to alleviate future vibration. In areas of the driveline where a slip shaft is required, the splined slip joint shall be coated with Glide Coat®.

FUEL FILTER/WATER SEPARATOR

The fuel system shall have a Racor GreenMAX 6600R fuel filter/water separator as a primary filter. The fuel filter shall have a drain valve and a see-through cover to allow visual inspection of fuel and filter condition. The Racor 6600R shall meet engine requirements for particulate size, collection capacity, removal efficiency, and water removal efficiency. The filter shall be capable of handling a maximum flow rate of 150 gallons per hour.

A secondary fuel filter shall be included as approved by the engine manufacturer.

An instrument panel lamp and audible alarm which indicates when water is present in the fuel-water separator shall also be included.

FUEL LINES

The fuel system supply and return lines installed from the fuel tank to the engine shall be black textile braided lines which are reinforced with braided high tensile steel wire. The fuel lines shall be connected with reusable steel fittings.

FUEL SHUTOFF VALVE

There shall be two (2) fuel shutoff valves which shall be installed, one (1) in the fuel draw line at the primary fuel filter and one (1) in the fuel outlet line at the primary fuel filter to allow the fuel filters to be changed without loss of fuel to the fuel pump.

A third fuel shutoff valve shall be installed in the fuel draw line, near the fuel tank to allow maintenance to be performed with minimal loss of fuel.

ELECTRIC FUEL PRIMER

Integral to the engine assembly is an electric lift pump that serves the purpose of pre-filter fuel priming.

FUEL COOLER

An aluminum cross flow air to fuel cooler shall be provided to lower fuel temperature allowing the vehicle to operate at higher ambient temperatures. The fuel cooler shall be located behind the rear axle.

FUEL TANK

The fuel tank shall have a capacity of one-hundred (100) gallons and shall measure 35.00 inches in width X 15.00 inches in height X 48.00 inches in length.

The baffled tank shall have a vent port to facilitate venting to the top of the fill neck for rapid filling without "blow-back" and a roll over ball check vent for temperature related fuel expansion and draw.

The tank is designed with dual draw tubes and sender flanges. The tank shall have 2.00 inch NPT fill ports for right or left hand fill. A 0.50 inch NPT drain plug shall be centered in the bottom of the tank.

The fuel tank shall be mounted below the frame, behind the rear axle. Two (2) three-piece strap hanger assemblies with "U" straps bolted midway on the fuel tank front and rear shall be utilized to allow the tank to be easily lowered and removed for service purposes. Rubber isolating pads shall be provided between the tank and the upper tank mounting brackets. Strap mounting studs through the rail, hidden behind the body shall not be acceptable.

FUEL TANK MATERIAL AND FINISH

The fuel tank shall be constructed of 12 gauge aluminized steel. The exterior of the tank shall be powder coated black and then painted to match the frame components.

All powder coatings, primers and paint shall be compatible with all metals, pretreatments and primers used. The cross hatch adhesion test per ASTM D3359 Method B, results to be 5B minimum. The pencil hardness test per ASTM D3363 shall have a final post-cured pencil hardness of H-2H. The direct impact resistance test per ASTM D2794, results to be 5B minimum.

Any proposals offering painted fuel tanks with variations from the above process shall not be accepted. The film thickness of vendor supplied parts shall also be sufficient to meet the performance standards as stated above.

FUEL TANK STRAP MATERIAL

The fuel tank straps shall be constructed of ASTM A-36 steel. The fuel tank straps shall be powder coated black and then painted to match the frame components if possible.

FUEL TANK FILL PORT

The fuel tank fill ports shall be provided with two (2) left fill ports located one (1) in the forward position and one (1) in the middle position and the right fill port located in the rearward position of the fuel tank.

FUEL TANK DRAIN PLUG

A 0.5 inch NPT magnetic drain plug shall be centered in the bottom of the fuel tank.

FRONT AXLE

The front axle shall include an independent front suspension (IFS) offering superior ride and improved handling.

The suspension shall utilize fully independent double wishbone arms with carrier and kingpin for optimized scrub radius. Air springs are tuned for ride and help reduce suspension weight. The IFS reduces turn radius with improved wheel cut over beam axles. The hydraulic damper shall feature rebound control to ensure the maximum load stability and superior driver comfort. The IFS system shall improve handling and offer better braking because of improved ground to tire ratio. This design shall allow for independent adjustment of the vehicle's alignment settings. The IFS shall include an auxiliary transverse leaf spring.

Proposals offering independent front axles comprised of torsion bar style suspensions shall not be considered.

FRONT AXLE WARRANTY

The front axle shall be warranted by Tuthill for three (3) years or 150,000 miles, which ever comes first. Details of the Tuthill warranty are provided on the PDF document attached to this option.

FRONT WHEEL BEARING LUBRICATION

The front axle wheel bearings shall be lubricated with oil. The oil level can be visually checked via clear inspection windows in the front axle hubs.

FRONT SHOCK ABSORBERS

Two (2) Koni shock absorbers shall be provided and installed as part of the front suspension system. Each shock shall deliver improved road handling and durability.

FRONT SUSPENSION

The chassis shall include an independent front suspension (IFS) system. The known advantages of IFS systems can be improved handling and better braking due to the increase in tire surface to ground contact area. The suspension travel of the IFS shall be approximately 6.50 inches, providing 3.00 inches bounce and 3.50 inches rebound of the suspension. The IFS front axle shall be rated between 21,000 and 24,000 pounds.

STEERING COLUMN/ WHEEL

The cab shall include a Douglas Autotech steering column which shall include a seven (7) position tilt, a 2.25 inch telescopic adjustment, and an 18.00 inch, four (4) spoke steering wheel located at the driver's position. The steering wheel shall be covered with black polyurethane foam padding.

The steering column shall contain a horn button, self-canceling turn signal switch, four-way hazard switch and headlamp dimmer switch.

ELECTRONIC POWER STEERING FLUID LEVEL INDICATOR

The power steering fluid shall be monitored electronically and shall send a signal to activate an audible alarm and visual warning in the instrument panel when fluid level falls below normal.

POWER STEERING PUMP

The hydraulic power steering pump shall be a TRW PS and shall be gear driven from the engine. The pump shall be a balanced, positive displacement, sliding vane type. The power steering system shall include an oil to air passive cooler.

FRONT AXLE CRAMP ANGLE

The chassis shall have a front axle cramp angle of 48-degrees to the left and right.

POWER STEERING GEAR

The power steering gear shall be a TRW model TAS 85/RCS 85.

CHASSIS ALIGNMENT

The chassis frame rails shall be measured to insure the length is correct and cross checked to make sure they run parallel and are square to each other. The front and rear axles shall be laser aligned. The front tires and wheels shall be aligned and toe-in set on the front tires by the chassis manufacturer.

REAR AXLE

The rear axle shall be a Meritor model RS-23-186 single drive axle. The axle shall include precision forged, single reduction differential gearing, and shall have a fire service rated capacity of 24,000 pounds.

The axle shall be built of superior construction and quality components to provide the rugged dependability needed to stand up to the fire industry's demands. The axle shall include rectangular shaped, hot-formed housing with a standard wall thickness of 0.50 of an inch for extra strength and rigidity and a rigid differential case for high axle strength and reduced maintenance.

The axle shall have heavy-duty Hypoid gearing for longer life, greater strength and quieter operation. Industry-standard wheel ends for compatibility with both disc and drum brakes, and unitized oil seal technology to keep lubricant in and help prevent contaminant damage will be used.

REAR AXLE DIFFERENTIAL LUBRICATION

The rear axle differential shall be lubricated with oil.

REAR AXLE WARRANTY

The rear axle shall be warranted by Meritor for five (5) years with unlimited miles under the general service application. Details of the Meritor warranty are provided on the PDF document attached to this option.

REAR WHEEL BEARING LUBRICATION

The rear axle wheel bearings shall be lubricated with oil.

VEHICLE TOP SPEED

The top speed of the vehicle shall be approximately 68 MPH +/-2 MPH at governed engine RPM.

REAR SUSPENSION

The single rear axle shall feature a Hendrickson Firemaax™ air suspension. The suspension shall include two optimized air springs mounted to cast structural trailing arms, a transverse cross beam for increased roll stability and two heavy duty shock absorbers. Dual air height control valves shall be installed to ensure equal frame height on both sides of the vehicle regardless of the load. Axle alignment is maintained using two eccentric bushings at each frame bracket.

The rear suspension capacity shall be rated at 24,000 pounds.

REAR SHOCK ABSORBERS

Shock absorbers shall be supplied by the suspension manufacturer and installed on the rear axle suspension.

TIRE INTERMITTENT SERVICE RATING

The chassis shall be rated using the stamped rating on the side of the tire as the basis for determining the maximum vehicle load and speed.

FRONT TIRE

The front tires shall be Bridgestone 425/65R-22.5 20PR "L" tubeless radial M864 wide base tough tread style.

The front tire stamped load capacity shall be 22,800 pounds per axle with a nominal speed rating of 68 miles per hour when properly inflated to 120 pounds per square inch.

The Bridgestone Intermittent Service Rating maximum load capacity shall be 24,400 pounds per axle with a speed rating of 68 miles per hour when properly inflated to 120 pounds per square inch.

The Bridgestone Intermittent Service Rating maximum speed capacity shall be 22,800 pounds per axle with a speed rating of 75 miles per hour when properly inflated to 120 pounds per square inch.

The Bridgestone Intermittent Service Rating limits the operation of the emergency vehicle to no more than fifty (50) miles of continuous operation under maximum recommended payload, or without stopping for at least twenty (20) minutes. The emergency vehicle must reduce its speed to no more than 50 MPH after the first fifty (50) miles of travel.

REAR TIRE

The rear tires shall be Bridgestone 12R-22.5 16PR "H" tubeless radial M799 all-weather tread.

The rear tire stamped load capacity shall be 27,120 pounds per axle with a speed rating of 75 miles per hour when properly inflated to 120 pounds per square inch.

The Bridgestone Intermittent Service Rating maximum load capacity shall be 29,018 pounds per axle with a speed rating of 75 miles per hour when properly inflated to 120 pounds per square inch.

The Bridgestone Intermittent Service Rating limits the operation of the emergency vehicle to no more than fifty (50) miles of continuous operation under maximum recommended payload, or without stopping for at least twenty (20) minutes. The emergency vehicle must reduce its speed to no more than 50 MPH after the first fifty (50) miles of travel.

REAR AXLE RATIO

The rear axle ratio shall be 5.38:1.

TIRE PRESSURE INDICATOR

There shall be electronic chrome LED valve caps shipped loose for installation by the OEM which shall illuminate with a red LED when tire pressure drops 8psi provided. The valve caps are self-calibrating and set to the pressure of the tire upon installation.

FRONT WHEEL

The front wheels shall be Alcoa hub piloted, 22.50 inch X 12.25 inch aluminum wheels. The outer face of the wheels shall feature Alcoa's Dura-Bright® finish as an integral part of the wheel surface. Alcoa Dura-Bright® wheels keep their shine without polishing. Brake dust, grime and road debris are easily removed by simply cleaning the wheels with soap and water. The hub piloted mounting system shall provide easy installation and shall include two-piece flange nuts.

REAR WHEEL

The rear wheels shall be Alcoa hub piloted, 22.50 inch X 9.00 inch aluminum wheels with a polished outer surface and Alcoa Dura-Bright® wheel treatment as an integral part of the wheel surface. The inner rear wheels shall be Alcoa hub piloted, 22.50 inch X 9.00 inch aluminum wheels with a polished inner and outer surface and Alcoa Dura-Bright® wheel treatment as an integral part of the wheel surface. The hub piloted mounting system shall provide easy installation and shall include two-piece flange nuts.

BALANCE WHEELS AND TIRES

All of the wheels and tires, including any spare wheels and tire assemblies, shall be dynamically balanced.

BRAKE SYSTEM

A rapid build-up air brake system shall be provided. The air brakes shall include, at a minimum, a two (2) air tank, three (3) reservoir system with a total of 4152 cubic inch of air capacity. A floor mounted treadle valve shall be mounted inside the cab for graduated control of applying and releasing the brakes. An inversion valve shall be installed to provide a service brake application in the unlikely event of primary air supply loss. All air reservoirs provided on the chassis shall be labeled for identification.

The rear axle spring brakes shall automatically apply in any situation when the air pressure falls below 25 PSI and shall include a mechanical means for releasing the spring brakes when necessary. An audible alarm shall designate when the system air pressure is below 60 PSI.

A four (4) sensor, four (4) modulator Anti-lock Braking System (ABS) shall be installed on the front and rear axles in order to prevent the brakes from locking or skidding while braking during hard stops or on icy or wet surfaces. This in turn shall allow the driver to maintain steering control under heavy braking and in most instances, shorten the braking distance. The electronic monitoring system shall incorporate diagonal circuitry which shall monitor wheel speed during braking through a sensor and tone ring on each wheel. A dash mounted ABS lamp shall be provided to notify the driver of a system malfunction. The ABS system shall automatically disengage the auxiliary braking system device when required. The speedometer screen shall be capable of reporting all active defaults using PID/SID and FMI standards.

Additional safety shall be accommodated through Automatic Traction Control (ATC) which shall be installed on the single rear axle. The ATC system shall apply the ABS when the drive wheels lose traction. The system shall scale the electronic engine throttle back to prevent wheel spin while accelerating on ice or wet surfaces.

A virtual style switch shall be provided and properly labeled "mud/snow". When the switch is pressed once, the system shall allow a momentary wheel slip to obtain traction under extreme mud and snow conditions. During this condition the ATC light shall blink continuously notifying the driver of activation. Pressing the switch again shall deactivate the mud/snow feature.

The Electronic Stability Control (ESC) unit is a functional extension of the electronic braking system. It is able to detect any skidding of the vehicle about its vertical axis as well as any rollover tendency. The control unit comprises an angular-speed sensor that measures the vehicle's motion about the vertical axis, caused, for instance, by cornering or by skidding on a slippery road surface. An acceleration sensor measures the vehicle's lateral acceleration. The Controller Area Network (CAN) bus provides information on the steering angle. On the basis of lateral acceleration and steering angle, an integrated microcontroller calculates a theoretical angular speed for the stable vehicle condition.

FRONT BRAKES

The front brakes shall be Knorr/Bremse SN7 disc brakes with 17.00 inch vented rotors.

REAR BRAKES

The rear brakes shall be Meritor EX225 Disc Plus disc brakes with 17.00 inch vented rotors.

PARK BRAKE

Upon application of the push-pull valve in the cab, the rear brakes will engage via mechanical spring force. This is accomplished by dual chamber rear brakes, satisfying the FMVSS parking brake requirements.

SUPPLEMENTAL BRAKE

A supplemental brake engagement shall be supplied that can only be engaged while the rear spring brakes are engaged. In addition to the mechanical rear brake engagement, the front service brakes shall also be engaged via air pressure, providing additional braking capability. Front service brake activation shall be accomplished with activation of the rear mechanical park brake valve.

PARK BRAKE CONTROL

A Meritor-Wabco manual hand control push-pull style valve shall operate the parking brake system. The control shall be yellow in color.

The parking brake actuation valve shall be mounted in the switch panel. A horizontal orientation guard shall be installed over the parking brake control to prevent accidental application or release.

AIR DRYER

The brake system shall include a Wabco System Saver 1200 air dryer with an integral heater with a Metri-Pack sealed connector. The air dryer incorporates an internal turbo cutoff valve that closes the path between the air compressor and air dryer purge valve during the compressor "unload" cycle. The turbo cutoff valve allows purging of moisture and contaminants without the loss of turbo boost pressure. The air dryer shall be mounted behind the battery box on the left hand side.

FRONT BRAKE CHAMBERS

The front brakes shall be provided with type 24 brake chambers as supplied with the independent front suspension axle.

REAR BRAKE CHAMBERS

The rear axle shall include TSE 24/30 H.O.T. (High Output Technology) brake chambers shall convert the energy of compressed air into mechanical force and motion. This shall actuate the brake camshaft, which in turn shall operate the foundational brake mechanism forcing the brake pads against the brake rotor.

AIR COMPRESSOR

The air compressor provided for the engine shall be a Wabco® SS318 single cylinder pass-through drive type compressor which shall be capable of producing 18.7 CFM at 1200 engine RPMs. The air compressor shall feature a higher delivery efficiency translating to more air delivery per horsepower absorbed. The compressor shall include an aluminum cylinder head which shall improve cooling, reduce weight and decrease carbon formation. Superior piston and bore finishing technology shall reduce oil consumption and significantly increasing the system component life.

AIR GOVERNOR

An air governor shall be provided to control the cut-in and cut-out pressures of the engine mounted air compressor. The governor shall be calibrated to meet FMVSS requirements. The air governor shall be located on the air dryer bracket.

AUXILIARY AIR RESERVOIR

Two (2) additional air reservoirs, one (1) with a 1200 cubic inch capacity and one (1) with a 2084 cubic inch capacity, for a total of 3284 cubic inch of additional air capacity shall be installed on the chassis. Each reservoir shall be isolated with a 90 PSI pressure protection valve on the reservoir supply side to prevent depletion of the air to the air brake system.

The auxiliary tanks shall act as an additional reserve supply to the air system for air tool, or other non-service brake use.

MOISTURE EJECTORS

Manual cable actuated drain valves shall be installed on all reservoirs of the air supply system. The actuation pull cables shall be coiled and tied at each drain valve. The supplied cables when extended shall be sufficient in length to allow each drain to be activated from the side of the apparatus.

AIR SUPPLY LINES

The air system on the chassis shall be plumbed with color coded reinforced nylon tubing air lines. The primary (rear) brake line shall be green, the secondary (front) brake line red, the parking brake line orange and the auxiliary (outlet) shall be blue.

Brass compression type fittings shall be used on the nylon tubing. All drop hoses shall be fiber reinforced neoprene covered hoses.

All nylon air tubing on the chassis shall be covered with high temperature plastic split loom.

AIR TANK SPACERS

There shall be spacers included with the air tank mounting. The spacers shall move the air tanks 1.50 inches inward towards the center of the chassis. This shall provide clearance between the air tanks and the frame for body U-bolt clearance.

REAR AIR TANK MOUNTING

If a combination of wheel base, air tank quantity, or other requirements necessitate the location of one or more air tanks to be mounted rear of the fuel tank, these tank(s) will be mounted parallel to frame.

WHEELBASE

The chassis wheelbase shall be 238.00 inches.

REAR OVERHANG

The chassis rear overhang shall be 90.00 inches.

FRAME

The frame shall consist of double rails running parallel to each other with cross members forming a ladder style frame. The frame rails shall be formed in the shape of a "C" channel, with the outer rail measuring 10.25 inches high X 3.50 inches deep upper and lower flanges X 0.38 inches thick with an inner channel of 9.44 inches high X 3.13 inches deep and 0.38 inches thick. Each rail shall be constructed of 110,000 psi minimum yield high strength low alloy steel. Each double rail section shall be rated by a Resistance Bending Moment (RBM) minimum of 3,213,100 inch pounds and have a minimum section modulus of 29.21 cubic inches. The frame shall measure 35.00 inches in width.

Proposals calculating the frame strength using the "box method" shall not be considered.

Proposals including heat treated rails shall not be considered. Heat treating frame rails produces rails that are not uniform in their mechanical properties throughout the length of the rail. Rails made of high strength, low alloy steel are already at the required yield strength prior to forming the rail.

A minimum of seven (7) fully gusseted 0.25 inch thick cross members shall be installed. The inclusion of the body mounting, or bumper mounting shall not be considered as a cross member. The cross members shall be attached using zinc coated grade 8 fasteners. The bolt heads shall be flanged type, held in place by distorted thread flanged lock nuts. Each cross member shall be mounted to the frame rails utilizing a minimum of 0.25 inch thick gusset reinforcement plates at all corners balancing the area of force throughout the entire frame. The cross members shall be double back to back cross members wherever possible.

Any proposals not including additional reinforcement for each cross member shall not be considered.

All relief areas shall be cut in with a minimum 2.00 inch radius at intersection points with the edges ground to a smooth finish to prevent a stress concentration point.

FRAME CLEAR AREA

The chassis frame shall be left clear of chassis mounted components inside or outside the frame rails within the first 30.00 inches behind the cab to allow space for OEM installed components. Cross members may be installed in the clear area if required for proper frame or driveline configuration.

FRAME PAINT

The frame rails shall be hot dip galvanized prior to assembly and attachment of any components. The components that shall be galvanized shall include:

- Main frame "C" channel or channels

The frame parts which are not galvanized shall be powder coated prior to any attachment of components. Parts which shall be powder coated shall include but are not limited to:

- Steering gear bracket
- Front splayed rails and fish plates
- Bumper extensions
- Cross members
- Cross member gussets
- Fuel tank mounting brackets
- Fuel tank straps (unless material/finish is specified in 3130 subcat)
- Air tanks (unless color coded tanks are specified in 3205 subcat)
- Air tank mounting brackets
- Exhaust mounting brackets
- Air cleaner skid plate
- Radiator skid plate
- Battery supports, battery trays and battery covers

Other non-galvanized under carriage components which are received from the suppliers with coatings already applied shall include but are not limited to:

- Suspension components
- Front and rear axles

All powder coatings, primers and paint used on the non-galvanized components shall be compatible with all metals, pretreatments and primers used. The cross hatch adhesion test per ASTM D3359 shall not have a fail of more than ten (10) squares. The pencil hardness test per ASTM D3363 shall have a final post-cured pencil hardness of H-2H. The direct impact resistance test per ASTM D2794 shall have an impact resistance of 120.00 inches per pound at 2 mils.

FRAME ASSEMBLY STRUCTURAL

Purchaser shall receive a Frame Assembly Structural Twenty (20) Years or 100,000 Miles limited warranty in accordance with, and subject to, warranty certificate RFW0304. The warranty certificate is incorporated by reference into this proposal, and included with this proposal or available upon request.

FRAME RAIL CORROSION

Purchaser shall receive a Frame Rail Corrosion (Zinc Plate and Powder Coat) Twenty Five (25) Years or 150,000 Miles limited warranty in accordance with, and subject to, warranty certificate RFW0316. The warranty certificate is incorporated by reference into this proposal, and included with this proposal or available upon request.

FRAME COMPONENTS CORROSION

Purchaser shall receive a Frame Components Corrosion (Powder Coat) Three (3) Years or 48,000 Miles limited warranty in accordance with, and subject to, warranty certificate RFW0313. The warranty certificate is incorporated by reference into this proposal, and included with this proposal or available upon request.

FRONT BUMPER

The chassis shall be equipped with a severe duty front bumper constructed from structural steel channel. The bumper material shall be 0.38 thick ASTM A36 steel which shall measure 12.00 inches high with a 3.05 inch flange and shall be 104.50 inches wide with angled front corners.

The bumper shall be primed and painted as specified.

FRONT BUMPER EXTENSION LENGTH

The front bumper shall be extended approximately 28.00 inches ahead of the cab.

FRONT BUMPER PAINT

The front bumper shall be painted the same as the lower cab color.

MECHANICAL SIREN

A Federal Q2B™ siren shall be provided and installed by the customer.

AIR HORN

The chassis shall include two (2) Hadley brand E-Tone air horns which shall measure 24.00 inches long with a 6.00 inch round flare. The air horns shall be trumpet style with a chrome finish on the exterior and a painted finish deep inside the trumpet.

AIR HORN LOCATION

The air horns shall be recess mounted in the front bumper fascia between the frame rails in the right and left outboard positions.

AIR HORN RESERVOIR

One (1) air reservoir, with a 2084 cubic inch capacity, shall be installed on the chassis to act as a supply tank for operating air horns. The reservoir shall be isolated with a 90 PSI pressure protection valve on the reservoir supply side to prevent depletion of the air to the air brake system.

ELECTRONIC SIREN SPEAKER

There shall be two (2) Whelen Engineering Inc. model SA314A, 100 watt speakers provided. Each speaker shall measure 6.40 inches tall X 6.17 inches wide X 3.14 inches deep. Each speaker shall have a natural cast aluminum finish and shall be installed using a polished trim ring.

ELECTRONIC SIREN SPEAKER LOCATION

The two (2) electronic siren speakers shall be located on the front bumper face outboard of the frame rails with one (1) on the right side and one (1) on the left side in the outboard positions.

FRONT LICENSE PROVISION

The bumper shall include four (4) mounting holes and screws to allow for a license plate to be installed by the OEM or end user. The mounting holes shall be drilled and tapped for ¼-20 threaded bolts.

CAB TILT SYSTEM

The entire cab shall be capable of tilting approximately 45-degrees to allow for easy maintenance of the engine and transmission. The cab tilt pump assembly shall be located on the right side of the chassis above the battery box.

The electric-over-hydraulic lift system shall include an ignition interlock and red cab lock down indicator lamp on the tilt control which shall illuminate when holding the "Down" button to indicate safe road operation.

It shall be necessary to activate the master battery switch and set the parking brake in order to tilt the cab. As a third precaution the ignition switch must be turned off to complete the cab tilt interlock safety circuit.

Two (2) spring-loaded hydraulic hold down hooks located outboard of the frame shall be installed to hold the cab securely to the frame. Once the hold-down hooks are set in place, it shall take the application of pressure from the hydraulic cab tilt lift pump to release the hooks.

Two (2) cab tilt cylinders shall be provided with velocity fuses in each cylinder port. The cab tilt pivots shall be 1.90 inch ball and be anchored to frame brackets with 1.25 inch diameter studs.

A steel safety channel assembly, painted safety yellow shall be installed on the right side cab lift cylinder to prevent accidental cab lowering. The safety channel assembly shall fall over the lift cylinder when the cab is in the fully tilted position. A cable release system shall also be provided to retract the safety channel assembly from the lift cylinder to allow the lowering of the cab.

CAB TILT AUXILIARY PUMP

A manual cab tilt pump module shall be attached to the cab tilt pump housing.

CAB TILT LIMIT SWITCH

A cab tilt limit switch shall be installed. The switch will effectively limit the travel of the cab when being tilted. The limit adjustment of the switch shall be preset by the chassis manufacturer to prevent damage to the cab or any bumper mounted option mounted in the cab tilt arc. Further adjustment to the limit by the apparatus manufacturer shall be available to accommodate additional equipment.

CAB TILT CONTROL RECEPTACLE

A 25.00 foot cab tilt control harness shall be provided on the right side of frame just behind the cab. This harness shall consist of an 8.00 foot harness connected to the tilt pump and a 17.00 foot extension harness with a six (6) pin Deutsch connector with cap for mounting in a compartment in the body.

The remote control pendant shall include 20.00 feet of cable with a mating Deutsch connector. The remote control pendant shall be shipped loose with the chassis.

CAB TILT LOCK DOWN INDICATOR

The cab dash shall include a message located within the dual air pressure gauge which shall alert the driver when the cab is unlocked and ajar. The alert message shall cease to be displayed when the cab is in the fully lowered position and the hold down hooks are secured and locked to the cab mounts.

In addition to the alert message an audible alarm shall sound when the cab is unlocked and ajar and the parking brake is released.

CAB WINDSHIELD

The cab windshield shall have a surface area of 2969.88 square inches and be of a two (2) piece wraparound design for maximum visibility.

The glass utilized for the windshield shall include standard automotive tint. The left and right windshield shall be fully interchangeable thereby minimizing stocking and replacement costs.

Each windshield shall be installed using black self locking window rubber.

GLASS FRONT DOOR

The front cab doors shall include a window which is 27.00 inches in width X 26.00 inches in height. These windows shall have the capability to roll down completely into the door housing. This shall be accomplished using electric actuation. The left and right front door windows shall be controlled using a switch on each respective side inner door panel. The driver's door shall include a switch for each powered door window in the cab.

There shall be an irregular shaped fixed window which shall measure 2.50 inches wide at the top, 8.00 inches wide at the bottom X 26.00 inches in height, more commonly known as "cozy glass" ahead of the front door roll down windows.

The windows shall be mounted within the frame of the front doors trimmed with a black anodized ring on the exterior.

GLASS TINT FRONT DOOR

The windows located in the left and right front doors shall include a dark gray automotive tint which shall allow forty-five percent (45%) light transmittance. The dark tint shall aid in cab cooling and help protect passengers from radiant solar energy.

GLASS REAR DOOR RH

The rear right hand side crew door shall include a window which is 27.00 inches in width X 26.00 inches in height. The window shall be a powered type and shall be controlled by a switch on the door panel ledge and on the driver's control panel.

GLASS TINT REAR DOOR RIGHT HAND

The window located in the right hand side rear window shall include a dark gray automotive tint which shall allow forty-five percent (45%) light transmittance. The dark tint shall aid in cab cooling and help protect passengers from radiant solar energy.

GLASS REAR DOOR LH

The left hand side of the cab where the middle side and rear door window would normally be shall include a window which is 50.00 inches in width X 26.00 inches in height. The window shall be a fixed type window. The window shall be mounted using self-locking window rubber.

GLASS TINT REAR DOOR LEFT HAND

The window located in the left hand side rear door shall include a dark gray automotive tint which shall allow forty-five percent (45%) light transmittance. The dark tint shall aid in cab cooling and help protect passengers from radiant solar energy.

GLASS SIDE MID RH

The cab shall include a window on the right side behind the front and ahead of the crew door which shall measure 16.00 inches wide X 26.00 inches high. This window shall be fixed within this space and shall be rectangular in shape. The window shall be mounted using self locking window rubber. The glass utilized for this window shall include a green automotive tint unless otherwise noted.

GLASS TINT SIDE MID RIGHT HAND

The window located on the right hand side of the cab between the front and rear doors shall include a dark gray automotive tint which shall allow forty-five percent (45%) light transmittance. The dark tint shall aid in cab cooling and help protect passengers from radiant solar energy.

CLIMATE CONTROL

A ceiling mounted combination defroster and cabin heating and air conditioning system shall be located above the engine tunnel area. The system covers and plenums shall be of severe duty design made of aluminum which shall be coated with a customer specified interior paint. The design of the system's covers shall provide quick access to washable air intake filters as well as easy access to other serviceable items.

The air delivery plenums provide targeted airflow directly to the vehicle occupants. Six (6) adjustable louvers will provide comfort for the front seat occupants and ten (10) adjustable louvers will provide comfort for the rear crew occupants.

The system shall be capable of producing up to 12 FPM of air velocity at all occupant seating positions. Separate front and rear blower motors shall be of brushless design and shall be controlled independently. It shall be capable of reducing the interior cabin air temperature from 122° F (+/- 3° F) to 80° F in thirty minutes with 50% relative humidity and full solar load as described in SAE J2646.

The system shall also provide heater pull up performance which meets or exceeds the performance requirements of SAE J1612 as well as defrost performance that meets or exceeds the performance requirements of SAE J381.

A gravity drain system shall be provided that is capable of evacuating condensate from the vehicle while on a slope of up to a 13% grade in any direction.

The air conditioning system plumbing shall be a mixture of custom bent zinc coated steel fittings and Aeroquip flexible hose with Aeroquip EZ-Clip fittings.

The overhead heater/defroster plumbing shall include an electronic flow control valve that re-directs hot coolant away from the evaporator, via a bypass loop, as the temperature control is moved toward the cold position.

Any component which needs to be accessed to perform system troubleshooting shall be accessible by one person using basic hand tools. Regularly serviced items shall be replaceable by one person using basic hand tools.

*****The chassis manufacturer recommends that the overall climate system performance be based off third-party testing in accordance with the Society of Automotive Engineering standards as a complete system.***

Individual component level BTU ratings is not an accurate indicator of the performance capability of the completed system. System individual component BTU ratings:

- Air conditioning evaporator total BTU/HR: 82,000
- Air conditioning condenser total BTU/HR: 59,000
- Heater coil total BTU/HR: 98,000

Performance data specified is based on testing performed by an independent third-party test facility using a medium four-door 10" raised roof cab equipped with an ISL engine.

CLIMATE CONTROL DRAIN

The climate control system shall include a gravity drain for water management. The gravity drain shall remove condensation from the air conditioning system without additional mechanical assistance.

CLIMATE CONTROL ACTIVATION

The heating, defrosting and air conditioning controls shall be in the center dash center switch panel, in a position which is easily accessible to the driver. The climate control shall be activated by a rotary switch.

HVAC OVERHEAD COVER PAINT

The overhead HVAC cover shall be painted with a multi-tone dark red texture finish.

A/C CONDENSER LOCATION

A roof mounted A/C condenser shall be installed centered on the cab forward of the raised roof against the slope rise.

A/C COMPRESSOR

The air-conditioning compressor shall be a belt driven, engine mounted compressor. The compressor shall be compatible with R134-a refrigerant.

*****The chassis manufacturer recommends that the overall climate system performance be based off third-party testing in accordance with the Society of Automotive Engineering standards as a complete system.***

Individual component level ratings are not an accurate indicator of the performance capability of the completed system.

Refrigerant Compressor displacement: 19.1 cubic inches per revolution.

CAB CIRCULATION FANS REAR

The cab shall include two (2) individually switched all metal construction 6.00 inch fans which shall be installed in the upper rear cab corners as far outboard as possible. The multi purpose fans can be used to increase air circulation or help defog windows.

UNDER CAB INSULATION

The underside of the cab tunnel surrounding the engine shall be lined with multi-layer insulation, engineered for application inside diesel engine compartments.

The insulation shall act as a noise barrier, absorbing noise thus keeping the decibel level in the cab well within NFPA recommendations. As an additional benefit, the insulation shall assist in sustaining the desired temperature within the cab interior.

The engine tunnel insulation shall measure approximately 0.30 inch thick including a multi-layer foil faced glass cloth and polyester fiber layer. The foil surface acts as protection against heat, moisture and other contaminants. The insulation shall meet or exceed FMVSS 302 flammability test.

The cab floor insulation shall measure 0.56 inch thick including a 1.0#/sf PVC barrier and a moisture and heat reflective foil facing, reinforced with fiberglass strands. The foil surface acts as protection against moisture and other contaminants. The insulation shall meet or exceed FMVSS 302 flammability test.

The insulation shall be cut precisely to fit each section and sealed for additional heat and sound deflection. The insulation shall be held in place by acrylic pressure sensitive adhesive. In addition, the insulation on the underside of the cab floor shall have aluminum pins with hard hat, hold in place fastening heads and an expanded metal overlay to assist in retaining the insulation tight against the cab. The insulation inside the tunnel shall have a removable aluminum overlay installed to protect the insulation and assist in retaining the insulation tight against the engine tunnel surfaces.

INTERIOR TRIM FLOOR

The floor of the cab shall be covered with a multi-layer mat consisting of 0.25 inch thick sound absorbing closed cell foam with a 0.06 inch thick non-slip vinyl surface with a pebble grain finish. The covering shall be held in place by a pressure sensitive adhesive and embossed treadplate trim that shall wrap 2" horizontally and vertically. All exposed seams shall be sealed with silicone caulk matching the color of the floor mat to reduce the chance of moisture and debris retention.

INTERIOR TRIM

The cab interior shall include trim on the front ceiling, rear crew ceiling, and the cab walls. It shall be easily removable to assist in maintenance. The trim shall be constructed of insulated vinyl over a hard board backing.

REAR WALL INTERIOR TRIM

The rear wall of the cab shall be trimmed with aluminum sheet metal coated with a customer specified interior paint or protective coating.

HEADER TRIM

The cab interior shall feature header trim over the driver and officer dash constructed of 5052-H32 Marine Grade, 0.13 inch thick aluminum.

TRIM CENTER DASH

The main center dash area shall be constructed of 5052-H32 Marine Grade, 0.13 inch thick aluminum plate. There shall be four (4) holes located on the top of the dash near each outer edge of the electrical access cover for ventilation. The center dash electrical access cover shall include a gas cylinder stay which shall hold the cover open during maintenance.

TRIM LH DASH

The left hand dash shall be constructed of 5052-H32 Marine Grade, 0.13 inch thick aluminum plate for a perfect fit around the instrument panel. For increased occupant protection the extreme duty left hand dash utilizes patent pending break away technology to reduce rigidity in the event of a frontal crash. The left hand dash shall offer lower vertical surface area to the left and right of the steering column to accommodate control panels.

TRIM RH DASH

The right hand dash shall be constructed of 5052-H32 Marine Grade, 0.13 of an inch thick aluminum plate and shall include a glove compartment with a hinged door and a Mobile Data Terminal (MDT) provision. The glove compartment size will measure 14.00 inches wide X 6.38 inches high X 5.88 inches deep. The MDT provision shall be provided above the glove compartment.

ENGINE TUNNEL TRIM

The cab engine tunnel shall be covered with a multi-layer mat consisting of 0.25 inch closed cell foam with a 0.06 inch thick non-slip vinyl surface with a pebble grain finish. The mat shall be held in place by pressure sensitive adhesive. The engine tunnel mat shall be trimmed with anodized aluminum stair nosing trim for an aesthetically pleasing appearance.

POWER POINT DASH MOUNT

The cab shall include two (2) dual universal serial bus (USB) charging receptacles in the cab dash switch panel to provide a power source for USB chargeable electrical equipment. Each USB receptacle shall include two ports and shall be capable of up to a 5 Volt 3.4 amp total output. Port 1 is optimized for fast charging at 1 amp. Port 2 is optimized for fast charging up to 2.4 amps, when used individually. The receptacles shall be wired battery direct.

STEP TRIM

Each cab entry door shall include a three step entry. The first step closest to the ground shall be constructed of SAE 304 stainless steel with embossed perforations and diamond shaped cutout. The perforations and cutouts shall allow water and other debris to flow through rather than becoming trapped within the stepping surface. The step shall feature a splash guard to reduce water and debris from splashing in to the step. The splash guard shall have drainage holes beneath the back of the step to allow debris and water to flow through rather than becoming trapped within the stepping surface. The stainless steel material shall have a number 8 mirror finish. The lower step shall be mounted to a frame which is integral with the construction of the cab for rigidity and strength. The middle step shall be integral with the cab construction and shall be trimmed in 0.08 inch thick 3003-H22 embossed aluminum tread plate.

STEP TRIM KICKPLATE

The cab steps shall include a kick plate in the rise of each step. The risers shall be trimmed in 3003-H22 bright aluminum tread-plate which is 0.07 inch thick.

UNDER CAB ACCESS DOOR

The cab shall include an under cab access door. The lower rear left side of the three (3) door cab shall include one (1) access door to provide access to the diesel exhaust fluid fill with a push and turn latch. The left side cab access door shall be painted to match the lower exterior of the cab.

INTERIOR DOOR TRIM

The interior trim on the doors of the cab shall consist of an aluminum panel constructed of Marine Grade 5052-H32 0.13 of an inch thick aluminum plate. The door panels shall include a painted finish.

DOOR TRIM CUSTOMER NAMEPLATE

The interior door trim on the front doors shall include a customer nameplate which states the vehicle was custom built for their Department.

CAB DOOR TRIM REFLECTIVE

In accordance with the current standards of NFPA, the body builder shall provide 96.00 square inches of reflective material on the interior of each cab door.

INTERIOR GRAB HANDLE "A" PILLAR

There shall be two (2) rubber covered 11.00 inch grab handles installed inside the cab, one on each "A" post at the left and right door openings. The left handle shall be located 7.88 inches above the bottom of the door window opening and the right handle shall be located 2.88 inches above the bottom of the door window opening. The handles shall assist personnel in entering and exiting the cab.

INTERIOR GRAB HANDLE FRONT DOOR

Each front door shall include one (1) ergonomically contoured 9.00 inch cast aluminum handle mounted horizontally on the interior door panels. The handles shall feature a textured black powder coat finish to assist personnel entering and exiting the cab.

INTERIOR GRAB HANDLE REAR DOOR

A black powder coated cast aluminum assist handle shall be provided on the inside of each rear crew door. A 30.00 inch long handle shall extend horizontally the width of the window just above the window sill. The handle shall assist personnel in exiting and entering the cab.

INTERIOR REAR WALL COMPARTMENT

The cab shall include an interior clear area provision for the side curtain crew airbag mounting to account for a compartment located on the left side at the rear wall to be installed by the body builder. The clear area shall extend from behind the standard rear door location to the rear wall. The provision allows appropriate airbag selection for clear airbag deployment and adequate protection and ejection mitigation.

INTERIOR SOFT TRIM COLOR

The cab interior soft trim surfaces shall be black in color.

INTERIOR TRIM SUNVISOR

The header shall include two (2) sun visors, one each side forward of the driver and officer seating positions above the windshield. Each sun visor shall be constructed of Masonite and covered with padded vinyl trim.

INTERIOR FLOOR MAT COLOR

The cab interior floor mat shall be black in color.

CAB PAINT INTERIOR

The inner door panel surfaces shall feature a dark red spray on bedliner coating.

HEADER TRIM INTERIOR PAINT

The metal surfaces in the header area shall feature a dark red spray on bedliner coating.

TRIM CENTER DASH INTERIOR PAINT

The entire center dash and any accessory pods attached to the dash shall feature a dark flat red spray on bedliner coating.

TRIM LEFT HAND DASH INTERIOR PAINT

The left hand dash shall feature a dark flat red spray on bedliner coating.

TRIM RIGHT HAND DASH INTERIOR PAINT

The right hand dash shall feature a dark flat red spray on bedliner coating.

REAR WALL INTERIOR PAINT

The rear wall of the cab shall be trimmed with aluminum sheet metal which shall feature a dark red Spar-Liner spray on bedliner coating.

DASH PANEL GROUP

The main center dash area shall include three (3) aluminum removable panels located one (1) to the right of the driver position, one (1) in the center of the dash and one (1) to the left of the officer position. The panels shall be coated with a black texture finish. The center panel shall be within comfortable reach of both the driver and officer.

SWITCHES CENTER PANEL

The center dash panel shall include no rocker switches or legends.

SWITCHES LEFT PANEL

The left dash panel shall include one (1) windshield wiper/washer control switch located in the left hand side of the panel. The switch shall have backlighting provided.

SWITCHES RIGHT PANEL

The right dash panel shall include eight (8) rocker switch positions in a four (4) over four (4) switch configuration.

A rocker switch with a blank legend installed directly above shall be provided for any position without a switch and legend designated by a specific option. The non-specified switches shall be two-position, black switches with a green indicator light. Each blank switch legend can be custom engraved by the body manufacturer. All switch legends shall have backlighting provided.

SEAT BELT WARNING

A Weldon seat belt warning system, integrated with the Vehicle Data Recorder system, shall be installed for each seat within the cab. The system shall provide a visual warning indicator in the Vista display and control screen(s) and a fast tone audible alarm. The wiring connections at each seat shall have heat shrink tubing applied so that the wiring cannot be easily disconnected to disable the system.

The warning system shall activate when any seat is occupied with a minimum of 60 pounds, the corresponding seat belt remains unfastened, and the park brake is released. The warning system shall also activate when any seat is occupied, the corresponding seat belt was fastened in an incorrect sequence, and the park brake is released. Once activated, the visual indicators and applicable audible alarm shall remain active until all occupied seats have the seat belts fastened.

SEAT MATERIAL

The Bostrom Firefighter seats shall include a covering of extra high strength, wear resistant fabric made of durable low seam Durawear Plus™ ballistic polyester. A PVC coating shall be bonded to the back side of the material to help protect the seats from UV rays and from being saturated or contaminated by fluids. Durawear Plus™ meets or exceeds specification of the common trade name Imperial 1800. The material meets FMVSS 302 flammability requirements.

If applicable, Theatre style seats located in the cab shall be high strength, wear resistant fabric made of durable ballistic polyester. A PVC coating shall be bonded to the back side of the material to help protect the seats from UV rays and from being saturated or contaminated by fluids. Common trade names for this material are Imperial 1200 and Durawear.

SEAT COLOR

All seats supplied with the chassis shall be black in color. All seats shall include red seat belts.

SEAT BACK LOGO

The seat backs shall include the logo for the Houston Fire Department of Houston, Texas. The logo shall be centered on the standard headrest of the seat back and on the left side of a split headrest.

SEAT DRIVER

The driver's seat shall be an H.O. Bostrom 400 Series Sierra model seat with air suspension. The four-way seat shall feature 3.00 inch vertical travel air suspension and manual fore and aft adjustment with 5.00 inches of travel. The suspension control shall be located on the seat below the left front corner of the bottom cushion. The seat shall also feature integral springs to isolate shock.

The seat position shall include a three-point shoulder harness with lap belt and an automatic retractor attached to the cab. The buckle portion of the seat belt shall be mounted on a semi-rigid stalk extending from the seat base within easy reach of the occupant.

The minimum vertical dimension from the seat H-point to the ceiling for this belted seating position shall be 37.00 inches measured with the seat suspension height adjusted to the upper limit of its travel.

This model of seat shall have successfully completed the static load tests set forth by FMVSS 207, 209, and 210 in effect at the time of manufacture. This testing shall include a simultaneous forward load of 3000 pounds each on the lap and shoulder belts and twenty (20) times the weight through the center of gravity.

The materials used in construction of the seat shall also have successfully completed testing with regard to the flammability of materials used in the occupant compartments of motor vehicles as outlined in FMVSS 302, of which dictates the allowable burning rate of materials in the occupant compartments of motor vehicles.

SEAT BACK DRIVER

The driver's seat shall feature a two (2) way adjustable lumbar support and offer an infinite fully reclining adjustable titling seat back. The seat back shall also feature a contoured head rest.

SEAT MOUNTING DRIVER

The driver's seat shall be installed in an ergonomic position in relation to the cab dash.

OCCUPANT PROTECTION DRIVER

The driver's position shall be equipped with the Advanced Protection System™ (APS). The APS shall selectively deploy integrated systems to protect against injuries in qualifying frontal impact, side impact, and rollover events. The increase in survivable space and security of the APS shall also provide ejection mitigation protection.

The driver's seating area APS shall include:

- Advanced seat belt system - retractor pre-tensioner tightens the seat belt around the driver, securing the occupant in the seat and the load limiter plays out some of the seat belt webbing to reduce seat belt to chest and torso force upon impact as well as mitigate head and neck injuries.
- Large side curtain airbag - protects the driver's head, neck, and upper body from dangerous cab side surfaces and contact points with intrusive surfaces as a result of a collision as well as provides ejection mitigation protection to the driver in a qualifying event by covering the window and the upper portion of the door.
- Dual knee airbags (patent pending) with energy management mounting (patent pending) - protects the driver's lower body from dangerous surface contact injuries, acceleration injuries, and from intrusion as well as locks the lower body in place so the upper body shall be slowed by the load limiting seat belt.

Steering wheel airbag - protects the driver's head, neck, and upper torso from contact injuries, acceleration injuries, and contact points with intrusive surfaces as a result of a collision.

SEAT OFFICER

The officer's seat shall be an H.O. Bostrom 400 Series Sierra model seat with air suspension. The four-way seat shall feature 3.00 inch vertical travel air suspension and manual fore and aft adjustment with 5.00 inches of travel. The suspension control shall be located on the seat below the left front corner of the bottom cushion. The seat shall also feature integral springs to isolate shock.

The seat position shall include a three-point shoulder harness with lap belt and an automatic retractor attached to the cab. The buckle portion of the seat belt shall be mounted on a semi-rigid stalk extending from the seat base within easy reach of the occupant.

The minimum vertical dimension from the seat H-point to the ceiling for this belted seating position shall be 37.00 inches measured with the seat suspension height adjusted to the upper limit of its travel.

This model of seat shall have successfully completed the static load tests set forth by FMVSS 207, 209, and 210 in effect at the time of manufacture. This testing shall include a simultaneous forward load of 3000 pounds each on the lap and shoulder belts and twenty (20) times the weight through the center of gravity.

The materials used in construction of the seat shall also have successfully completed testing with regard to the flammability of materials used in the occupant compartments of motor vehicles as outlined in FMVSS 302, of which dictates the allowable burning rate of materials in the occupant compartments of motor vehicles.

SEAT BACK OFFICER

The officer's seat shall feature a two (2) way adjustable lumbar support and offer an infinite fully reclining adjustable titling seat back. The seat back shall also feature a contoured head rest.

SEAT MOUNTING OFFICER

The officer's seat shall offer a special mounting position which is 2.00 inches rearward of the standard location offering increased leg room for the occupant.

OCCUPANT PROTECTION OFFICER

The officer's position shall be equipped with the Advanced Protection System™ (APS). The APS shall selectively deploy integrated systems to protect against injuries in qualifying frontal impact, side impact, and rollover events. The increase in survivable space and security of the APS shall also provide ejection mitigation protection.

The officer's seating area APS shall include:

- Advanced seat belt system - retractor pre-tensioner tightens the seat belt around the officer, securing the occupant in the seat and the load limiter plays out some of the seat belt webbing to reduce seat belt to chest and torso force upon impact as well as mitigate head and neck injuries.
- Large side curtain airbag - protects the officer's head, neck, and upper body from dangerous cab side surfaces and contact points with intrusive surfaces as a result of a collision as well as provides ejection mitigation protection to the officer in a qualifying event by covering the window and the upper portion of the door.

Knee airbags - protects the officer's lower body from dangerous surface contact injuries, acceleration injuries, and from contact points with intrusive surfaces as a result of a collision as well as locks the lower body in place so the upper body shall be slowed by the load limiting seat belt.

SEAT BELT ORIENTATION CREW

The crew position seat belts shall follow the standard orientation which extends from the outboard shoulder extending to the inboard hip.

SEAT FORWARD FACING OUTER LOCATION

The crew area shall include one (1) forward facing outboard seat located directly behind the engine tunnel on the right side of the cab.

SEAT CREW FORWARD FACING OUTER

The crew area shall include a seat in the forward facing outer position which shall be a theatre style series. The seat shall feature a padded seat cushion which shall be hinged and attached to the wall providing optimum space savings. The seat shall remain in the stored position until occupied.

The minimum vertical dimension from the seat H-point to the ceiling for each belted seating position shall be 35.00 inches.

The buckle portion of the seat belt shall be mounted on a rigid or semi-rigid stalk such that the buckle remains positioned in an accessible location. The seat belt assembly anchorages shall conform to the Federal Safety Standard (FMVSS) No. 210, "Seat belt assembly anchorages".

This model of seat shall have successfully completed the static load tests by FMVSS 207/210. This testing shall include a simultaneous forward load of 3000 pounds each on the lap and shoulder belts and twenty (20) times the weight through the center of gravity. This model of seat installed in the cab model, as specified, shall have successfully completed the dynamic sled testing using FMVSS 208 as a guide with the following accommodations. In order to reflect the larger size outfitted firefighters, the test dummy used shall be a 95th percentile hybrid III male weighing 225 pounds rather than the 50th percentile male dummy weighing 165 pounds as referenced in FMVSS 208. The model of seats shall also have successfully completed the flammability of materials used in the occupant compartments of motor vehicles as outlined in FMVSS 302, of which decides the burning rate of materials in the occupant compartments of motor vehicles.

SEAT BACK FORWARD FACING OUTER

The crew area shall include a seat in the forward facing outer position which shall be a theatre style seat. The rear wall padded trim shall act as the backrest for each seat.

There shall be a red, three-point shoulder harness with lap belt and an automatic retractor attached to the cab and available to the seat. The buckle portion of the seat belt shall be mounted on a rigid or semi-rigid stalk such that the buckle remains positioned in an accessible location. The seat belt assembly anchorages shall conform to the Federal Safety Standard (FMVSS) No. 210, "Seat belt assembly anchorages".

SEAT MOUNTING FORWARD FACING OUTER

The forward facing outer seat shall be mounted in the furthest outboard position facing the front of the cab.

OCCUPANT PROTECTION FFO

The forward facing outer seat position(s) shall be equipped with the Advanced Protection System™ (APS). The APS shall selectively deploy integrated systems to protect against injuries in qualifying frontal impact, side impact, and rollover events. The increase in survivable space and security of the APS shall also provide ejection mitigation protection.

Each forward facing outer seating position APS shall include:

- APS advanced seatbelt system - retractor pre-tensioners tighten the seat belts around each occupant, securing the occupants in seats and load limiters play out some of the seat belt webbing to reduce seat belt to chest and torso force upon impact as well as mitigate head and neck injuries.

Side curtain airbag - protects each occupant's head, neck, and upper body from dangerous cab side surfaces and contact points with intrusive surfaces as a result of a collision as well as provides ejection mitigation protection to each occupant in a qualifying event by covering the windows and walls adjacent to each seating position with an airbag custom designed for each cab configuration.

CAB FRONT UNDERSEAT STORAGE ACCESS

The left and right under seat storage areas shall have a solid aluminum hinged door with non-locking latch.

SEAT COMPARTMENT DOOR FINISH

All underseat storage compartment access doors shall feature a dark red spray on bedliner coating.

WINDSHIELD WIPER SYSTEM

The cab shall include a triple arm linkage wiper system which shall clear the windshield of water, ice and debris. There shall be two (2) windshield wipers; each shall be affixed to a radial arm. The wiper motor shall be activated by an intermittent wiper control located within easy reach of the driver's position. The windshield wipers shall be interlocked with the park brake allowing activation only when the park brake is released.

There shall be virtual button on the Vista display and control screen to override the park brake deactivation. This will reset when the park brake is cycled.

ELECTRONIC WINDSHIELD FLUID LEVEL INDICATOR

The windshield washer fluid level shall be monitored electronically. When the washer fluid level becomes low the yellow "Check Message Center" indicator light on the instrument panel shall illuminate and the message center in the dual air pressure gauge shall display a "Check Washer Fluid Level" message.

CAB DOOR HARDWARE

The cab entry doors shall be equipped with exterior pull handles, suitable for use while wearing firefighter gloves. The handles shall be made of aluminum with a chrome plated finish.

The interior exit door handles shall be flush paddle type with a black finish, which are incorporated into the upper door panel.

All cab entry doors shall include locks which are keyed alike. The door locks shall be designed to prevent accidental lockout.

The exterior pull handles shall include a scuff plate behind the handle constructed of polished stainless steel to help protect the cab finish.

DOOR LOCKS

Each cab entry door shall include a manually operated door lock. Each door lock may be actuated from the inside of the cab by means of a red knob located on the paddle handle of the respective door or by using a TriMark key from the exterior. The door locks are designed to prevent accidental lock out.

GRAB HANDLES

The cab shall include one (1) 18.00 inch three-piece knurled aluminum, anti-slip exterior assist handle, installed behind each cab door. The assist handle shall be made of extruded aluminum with a knurled finish to enable non-slip assistance with a gloved hand.

REARVIEW MIRRORS

Ramco model 6015-FFHR-750R bus style mirrors shall be provided. The mirror heads shall be polished cast aluminum and shall measure 9.75 inches wide X 13.00 inches high with an additional top mount convex assembly. The mirrors shall be mounted one (1) on each front cab corner radius below the windshield with 15.00 inch long polished cast aluminum arms.

The mirrors shall feature a remote controlled heated full flat glass and a top mounted remote controlled convex glass. The mirror control switches shall be located within easy reach of the driver. The mirrors shall be manufactured using the finest quality non-glare glass and shall feature a rigid mounting thereby reducing vibration. The mirrors shall be corrosion free under all weather conditions.

REARVIEW MIRROR HEAT SWITCH

The heat for the rearview mirrors shall be controlled through a virtual button on the Vista display and control screen.

CAB FENDER

Full width wheel well liners shall be installed on the extruded cab to limit road splash and enable easier cleaning. Each two-piece liner shall consist of an inner liner 16.00 inches wide made of vacuum formed ABS composite and an outer fenderette 3.50 inches wide made of SAE 304 polished stainless steel.

MUD FLAPS FRONT

The front wheel wells shall have mud flaps installed on them.

CAB EXTERIOR FRONT & SIDE EMBLEMS

The cab shall include three (3) Spartan emblems. There shall be one (1) installed on the front air intake grille and one (1) emblem on each of the cab sides. The cab shall also include one (1) Advanced Protection System shield emblem on each front door.

IGNITION

A master battery system with a keyless start ignition system shall be provided. Each system shall be controlled by a one-quarter turn Cole Hersee switch, both of which shall be mounted to the left of the steering wheel on the dash. A chrome push type starter button shall be provided adjacent to the master battery and ignition switches.

Each switch shall illuminate a green LED indicator light on the dash when the respective switch is placed in the "ON" position.

The starter button shall only operate when both the master battery and ignition switches are in the "ON" position.

BATTERY

The single start electrical system shall include six (6) Harris BCI 31 925 CCA batteries with a 210 minute reserve capacity and 4/0 welding type dual path starter cables per SAE J541.

BATTERY TRAY

The batteries shall be installed within two (2) stainless steel battery trays located on the left side and right side of the chassis, securely bolted to the frame rails. The battery trays shall be coated with the same material as the frame.

The battery trays shall include drain holes in the bottom for sufficient drainage of water. A durable, non-conducting, interlocking mat made by Dri-Dek shall be installed in the bottom of the trays to allow for air flow and help prevent moisture build up. The batteries shall be held in place by non-conducting phenolic resin hold down boards.

BATTERY BOX COVER

Each battery box shall include a stainless steel cover which protects the top of the batteries. Each cover shall include flush latches which shall keep the cover secure as well as a black powder coated handle for convenience when opening.

BATTERY CABLE

The starting system shall include cables which shall be protected by 275 degree F. minimum high temperature flame retardant loom, sealed at the ends with heat shrink and sealant.

BATTERY JUMPER STUD

The starting system shall include battery jumper studs. These studs shall be located in the forward most portion of the driver's side lower step, 8.00 inches apart. The studs shall allow the vehicle to be jump started, charged, or the cab to be raised in an emergency in the event of battery failure.

ALTERNATOR

The charging system shall include a 320 amp Leece-Neville 12 volt alternator. The alternator shall include a self-exciting integral regulator.

STARTER MOTOR

The single start electrical system shall include a Delco brand starter motor.

HEADLIGHTS

The cab front shall include four (4) rectangular LED headlamps with separate high and low beams mounted in bright chrome bezels. Each lamp shall include a heating system that de-ices the headlight.

HEADLIGHT LOCATION

The headlights shall be located on the front fascia of the cab directly above the front warning lights.

FRONT TURN SIGNALS

The front fascia shall include two (2) Whelen model M6 4.00 inch X 6.00 inch amber LED turn signals which shall be installed in a chrome radius mount housing above and outboard of the front warning and head lamps.

SIDE TURN/MARKER LIGHTS

The sides of the cab shall include two (2) Weldon 9186-8589-24 LED round side marker lights which shall be provided just behind the front cab radius corners.

MARKER AND ICC LIGHTS

In accordance with FMVSS, there shall be five (5) Weldon 9186-1500-20 LED cab marker lamps designating identification, center and clearance provided. These lights shall be installed on the face of the cab within full view of other vehicles from ground level.

HEADLIGHT AND MARKER LIGHT ACTIVATION

The headlights and marker lights shall be controlled via a virtual button on the Vista display. There shall be a virtual dimmer control on the Vista display to adjust the brightness of the dash lights.

LIGHTBAR SWITCH

The light bar shall be controlled by a virtual button on the Vista display and control screen. This button shall be clearly labeled for identification.

INTERIOR OVERHEAD LIGHTS

The cab shall include a Whelen 60CREGCS LED dome lamp located over each door. The dome lamps shall be circular in shape and shall measure approximately 6.00 inches in diameter. The lights shall include push buttons on each lamp to activate both the clear and red portions of the light individually.

INTERIOR OVERHEAD LIGHTS ACTIVATION

The clear portion of each lamp shall be activated by opening the respective door and via the multiplex display.

AUXILIARY DOME LIGHT REAR CREW

The cab shall include (2) two Whelen brand 60CREGCS 6.00 inch diameter red/clear type round shaped LED auxiliary dome lights in the headliner above the forward facing crew seats. The clear portion of each light shall be activated by the rear doors, a virtual button on the Vista display and a push button on the side of each light. The red portion of the light shall be activated by a virtual button on the Vista display and a push button on the side of each light.

LIGHTBAR PROVISION

There shall be one (1) light bar installed on the cab roof. The light bar shall be provided and installed by the chassis manufacturer. The light bar installation shall include mounting and wiring to a control switch on the cab dash.

CAB FRONT LIGHTBAR MODEL

The cab shall be provided with one (1) Whelen model F4N72 light bar. The light bar shall be 72.00 inches in length and feature eighteen (18) customizable pods.

See the light bar layout for specific details.

FRONT SCENE LIGHTS

The front of the cab shall include two (2) Whelen Pioneer model PCH2 contour roof mount scene lights installed on the brow of the cab.

Each 150 watt lamp head shall incorporate a 12 volt DC Super-LED combination flood/spot light installed in a die-cast aluminum housing. Each lamp head shall use a collimator/metalized redux spot/flood reflector assembly with Proclera™ silicone optics and a clear non-optic polycarbonate lens. The lens/reflector assembly shall utilize a liquid injected molded silicone gasket to be resistant to water, moisture, dust, and other environmental conditions. The PCH2 shall be vibration resistant. The Pioneer PC boards shall be conformal coated for additional protection. Each combination flood/spot light lamp head shall draw 13.0 amps in spotlight mode and generate 17,750 lumens total. Each lamp head shall measure 4.25 inches in height X 14.00 inches in width. The lamp heads and brackets shall be powder coated white.

FRONT SCENE LIGHT LOCATION

There shall be two (2) scene lights mounted to the front brow of the cab inboard of the outer front marker lights.

FRONT SCENE LIGHTS ACTIVATION

The front scene lighting shall be activated by a virtual button on the Vista display and control screen and a lighted momentary rocker switch on the dash.

SIDE SCENE LIGHTS

The cab shall include two (2) Whelen Pioneer model PFH2 semi-recess mount lights installed one (1) on each side of the cab.

Each 150 watt lamp head shall incorporate a 12 volt DC Super-LED flood light installed in a die-cast aluminum housing. Each lamp head shall use a collimator/metalized redux flood reflector assembly with Proclera™ silicone optics and a clear non-optic polycarbonate lens. The lens/reflector assembly shall utilize a liquid injected molded silicone gasket to be resistant to water, moisture, dust, and other environmental conditions. The PFH2 shall be vibration resistant. The Pioneer PC boards shall be conformal coated for additional protection. Each combination flood light lamp head shall draw 13.0 amps in spotlight mode and generate 17,750 lumens total. Each lamp head shall measure 4.25 inches in height X 14.00 inches in width. Each lamp head shall be mounted within a semi-recess housing featuring a chrome flange which shall measure 7.92 inches in height X 17.15 inches in width. The lamp heads and brackets shall be powder coated white.

SIDE SCENE LIGHT LOCATION

The scene lighting located on the left and right sides of the cab shall be mounted rearward of the cab "B" pillar in the 20.00 inch raised roof portion of the cab between the front and rear crew doors.

SIDE SCENE ACTIVATION

The scene lights shall be activated by two (2) lighted momentary rocker switches located in the switch panel, one (1) for each light and by two (2) virtual buttons on the Vista display and control screen(s), one (1) for each light.

GROUND LIGHTS

Each door shall include one (1) On-Scene brand Access LED mounted to the underside of the cab step below each door. The ground lights shall be 10.00 inches long and include a rough service anodized aluminum waterproof housing.

GROUND LIGHTS

The ground lighting shall be activated when the parking brake is set, by the opening of the door on the respective cab side, through a virtual button on the Vista display and control screen, when the truck is placed into reverse, and by the respective side turn signal.

LOWER CAB STEP LIGHTS

The middle step located at each door shall include one (1) On-Scene brand Access LED strip light which shall activate with the opening of the respective door.

INTERMEDIATE STEP LIGHTS

The intermediate step well area at each door shall include a TecNiq D06 LED light within a chrome housing. The egress step lights shall provide visibility to the step well area for the first step exiting the vehicle. The egress step lights shall activate with entry step lighting.

ENGINE COMPARTMENT LIGHT

There shall be a LED NFPA compliant light mounted under the engine tunnel for area work lighting on the engine. The light shall include a polycarbonate lens, a housing which is vibration welded and a bulb which shall be shock mounted for extended life. The light shall activate automatically when the cab is tilted.

DO NOT MOVE APPARATUS LIGHT

The front headliner of the cab shall include a flashing red Whelen Ion LED light clearly labeled "Do Not Move Apparatus". In addition to the flashing red light, an audible alarm shall be included which shall sound while the light is activated.

The flashing red light shall be located centered left to right for greatest visibility.

The light and alarm shall be interlocked for activation when either a cab door is not firmly closed or an apparatus compartment door is not closed, and the parking brake is released.

MASTER WARNING SWITCH

A master switch shall be included, as a virtual button on the Vista display and control screen which shall be labeled "E Master" for identification. The button shall feature control over all devices wired through it. Any warning device switches left in the "ON" position when the master switch is activated shall automatically power up.

HEADLIGHT FLASHER

An alternating high beam headlight flashing system shall be installed into the high beam headlight circuit which shall allow the high beams to flash alternately from left to right.

Deliberate operator selection of high beams will override the flashing function until low beams are again selected. Per NFPA, these clear flashing lights will also be disabled "On Scene" when the park brake is applied.

HEADLIGHT FLASHER SWITCH

The flashing headlights shall be activated through a virtual button on the Vista display and control screen.

INBOARD FRONT WARNING LIGHTS

The cab front fascia shall include two (2) Whelen M6 Super LED front warning lights in the left and right inboard positions. The lights shall feature multiple flash patterns including steady burn. The lights shall be mounted to the front fascia of the cab within a chrome bezel. The warning lights shall be set to emit the "DoubleFlash 150" in/out flash pattern.

INBOARD FRONT WARNING LIGHTS COLOR

The warning lights mounted on the cab front fascia in the inboard positions shall be red with a clear lens.

OUTBOARD FRONT WARNING LIGHTS

The cab front fascia shall include two (2) Whelen M6 Super LED front warning lights in the left and right outboard positions. The lights shall feature multiple flash patterns including steady burn. The lights shall be mounted to the front fascia of the cab within a chrome bezel. The warning lights shall be set to emit the "DoubleFlash 150" in/out flash pattern.

OUTBOARD FRONT WARNING LIGHTS COLOR

The warning lights mounted on the cab front fascia in the outboard position shall be red with a clear lens.

FRONT WARNING SWITCH

The front warning lights shall be controlled through a virtual control on the Vista display and control screen. This switch shall be clearly labeled for identification.

INTERSECTION WARNING LIGHTS

The chassis shall include two (2) Whelen M6 series Super LED intersection warning lights, one (1) each side. The lights shall feature multiple flash patterns including steady burn. The lights shall be set to flash "DoubleFlash 150" in/out flash pattern.

INTERSECTION WARNING LIGHTS COLOR

The intersection lights shall be red with a clear lens.

INTERSECTION WARNING LIGHTS LOCATION

The intersection lights shall be recess mounted into the side face of the bumper.

AUXILIARY INTERSECTION WARNING LIGHTS

The chassis shall include two (2) Whelen M6 series Super LED auxiliary intersection warning lights, one (1) each side. The lights shall be set to flash "DoubleFlash 150" in/out flash pattern.

AUXILIARY INTERSECTION WARNING LIGHTS COLOR

The auxiliary intersection warning lights shall be red with clear lens.

AUXILIARY INTERSECTION WARNING LIGHTS LOCATION

The auxiliary intersection warning lights shall be recessed in the steel channel bumper's angled front right and left corners.

SIDE WARNING LIGHTS

The cab sides shall include two (2) Whelen M6 Super LED warning lights, one (1) on each side. The lights shall feature multiple flash patterns including steady burn for solid colors and multiple flash patterns for split colors. The lights shall be mounted to the sides of the cab within a chrome bezel. The light shall be programmed to emit the "DoubleFlash 150" in/out flash pattern.

SIDE WARNING LIGHTS COLOR

The warning lights located on the side of the cab shall be red with clear lens.

SIDE WARNING LIGHTS LOCATION

The warning lights on the side of the cab shall be mounted over the front wheel well directly over the center of the front axle.

AUXILIARY SIDE WARNING LIGHTS

The cab sides shall include two (2) Whelen series M6 Super LED 4.00 inch X 6.00 inch warning lights, one (1) each side, which shall feature multiple flash patterns including steady burn. The warning lights shall be set to flash "DoubleFlash 150" left/right flash pattern.

AUXILIARY SIDE WARNING LIGHTS COLOR

The auxiliary warning lights located on the side of the cab shall be red with clear lens.

AUXILIARY SIDE WARNING LIGHTS LOCATION

The auxiliary warning lights on the side of the cab shall be mounted behind the rear crew door in the lowest available position.

SIDE AND INTERSECTION WARNING SWITCH

The side warning lights shall be controlled through a virtual button on the Vista display and control screen. This button shall be clearly labeled for identification.

TRAFFIC CONTROL

There shall be one (1) GTT (Global Traffic Technologies) Opticom model 795H traffic control optical emitter mounted in the lightbar on the front of the cab roof. There shall be an indicator light on the dash. The emitter shall be activated by the master warn switch and shall be deactivated when the parking brake is applied.

SIREN CONTROL HEAD

A Whelen 295HFSC9 electronic siren control head shall be provided. The siren head shall feature a 200-watt output, wail, yelp, manual siren, and hands free operation which shall allow the operator to turn the siren on and off from the horn ring if a horn/siren selector switch option is also selected. The siren shall be installed in the switch panel with a location specific to the customer's needs.

STEERING WHEEL HORN BUTTON SELECTOR SWITCH

A virtual button on the Vista display and control screen shall be provided to allow control of the electric horn or the air horn from the steering wheel horn button. The horn button selection shall default to the air horn each time the Vista screen power is cycled off and on. The electric horn shall be disabled when the virtual button is in the air horn control.

AUDIBLE WARNING LH FOOT SWITCH

A foot switch wired to actuate the mechanical siren(s) shall be supplied for installation in the front section of the cab for driver actuation.

MECHANICAL SIREN FOOT SWITCH LH

The mechanical siren foot switch shall be a Linemaster model 491-S.

MECHANICAL SIREN FOOT SWITCH LH LOCATION

The mechanical siren foot switch shall be located on the left hand side accessible to the driver between the steering column and the door.

MECHANICAL SIREN FOOT SWITCH LH POSITION

The mechanical siren foot switch shall be positioned outboard of any other foot switch, if applicable.

AUDIBLE WARNING LH FOOT SWITCH BRACKET

A 30.00 degree angled foot switch bracket, wide enough to accommodate (2) foot switches, shall be installed outboard of the steering column for specified driver accessible foot switch activations.

AIR HORN AUXILIARY ACTIVATION

The air horn activation shall be accomplished by a momentary rocker switch on the switch panel.

MECHANICAL SIREN BRAKE/AUXILIARY ACTIVATION

The mechanical siren shall be actuated by a momentary rocker switch in the switch panel on the dash. A red momentary siren brake rocker switch shall be provided in the switch panel on the dash. A virtual button for the siren brake shall be provided on the Vista display.

MECHANICAL SIREN INTERLOCK

The siren activation shall be interlocked with the park brake and shall only be active when master warning switch is on to prevent accidental engagement.

BACK-UP ALARM

A Preco-Matic model 1059 dual function, dual sound backup alarm shall be installed at the rear of the chassis with an auto-adjusting output level of 87 dB to 112 dB. The alarm shall automatically activate when the transmission is placed in reverse.

INSTRUMENTATION

An ergonomically designed instrument panel shall be provided. Each gauge shall be backlit with LED lamps. Stepper motor movements shall drive all gauges. The instrumentation system shall be multiplexed and shall receive ABS, engine, and transmission information over the J1939 data bus to reduce redundant sensors and wiring.

A twenty eight (28) icon lightbar message center with integral LCD odometer/trip odometer shall be included. The odometer shall display up to 999,999.9 miles. The trip odometer shall display 9,999.9 miles. The LCD message center screen shall be capable of custom configuration by the users for displaying certain vehicle status and diagnostic functions.

The instrument panel shall contain the following gauges:

One (1) three-movement gauge displaying vehicle speed, fuel level, and Diesel Exhaust Fluid (DEF) level. The primary scale on the speedometer shall read from 0 to 100 MPH, and the secondary scale on the speedometer shall read from 0 to 160 KM/H. The scale on the fuel and DEF level gauges shall read from empty to full as a fraction of full tank capacity. Red indicator lights in the gauge and an audible alarm shall indicate low fuel or low DEF at 1/8th tank level.

One (1) three-movement gauge displaying engine RPM, and primary and secondary air system pressures shall be included. The scale on the tachometer shall read from 0 to 3000 RPM. The scale on the air pressure gauges shall read from 0 to 150 pounds per square inch (PSI) with a red line zone indicating critical levels of air pressure. Red indicator lights in the gauge and an audible alarm shall indicate low air pressure.

One (1) four-movement gauge displaying engine oil pressure, coolant temperature, voltmeter, and transmission temperature shall be included. The scale on the engine oil pressure gauge shall read from 0 to 100 pounds PSI with a red line zone indicating critical levels of oil pressure. A red indicator light in the gauge and audible alarm shall indicate low engine oil pressure. The scale on the coolant temperature gauge shall read from 100 to 250 degrees Fahrenheit (°F) with a red line zone indicating critical coolant temperatures. A red indicator light in the gauge and audible alarm shall indicate high coolant temperature. The scale on the voltmeter shall read from 9 to 18 volts with a red line zone indicating critical levels of battery voltage. A red indicator light in the gauge and an audible alarm shall indicate high or low system voltage. The low voltage alarm shall indicate when the system voltage has dropped below 11.8 volts for more than 120 seconds in accordance with the requirements of NFPA 1901. The scale on the transmission temperature gauge shall read from 100 to 300 degrees °F with a red line zone indicating critical temperatures. A red indicator light in the gauge and an audible alarm shall indicate a high transmission temperature.

The light bar portion of the message center shall include twenty-eight (28) LED backlit indicators. The lightbar shall be split with fourteen (14) indicators on each side of the LCD message screen. The lightbar shall contain the following indicators and produce the following audible alarms when supplied in conjunction with applicable configurations:

RED INDICATORS

Stop Engine - indicates critical engine fault
Air Filter Restricted - indicates excessive engine air intake restriction
Park Brake - indicates parking brake is set
Low Coolant - indicates critically low engine coolant
Cab Tilt Lock - indicates the cab tilt system locks are not engaged.

AMBER INDICATORS

Malfunction Indicator Lamp (MIL) - indicates an engine emission control system fault
Check Engine - indicates engine fault
Check Transmission - indicates transmission fault
Anti-Lock Brake System (ABS) - indicates anti-lock brake system fault
High exhaust system temperature – indicates elevated exhaust temperatures
Water in Fuel - indicates presence of water in fuel filter
Wait to Start - indicates active engine air preheat cycle
Windshield Washer Fluid – indicates washer fluid is low
DPF restriction - indicates a restriction of the diesel particulate filter
Regen Inhibit - indicates regeneration of the DPF has been inhibited by the operator
Range Inhibit - indicates a transmission operation is prevented and requested shift request may not occur.
SRS - indicates a problem in the supplemental restraint system
Check Message - indicates a vehicle status or diagnostic message on the LCD display requiring attention.

GREEN INDICATORS

Left and Right turn signal indicators
ATC - indicates low wheel traction for automatic traction control equipped vehicles, also indicates mud/snow mode is active for ATC system
High Idle - indicates engine high idle is active.
Cruise Control - indicates cruise control is enabled
OK to Pump - indicates the pump is engaged and conditions have been met for pump operations
Pump Engaged - indicates the pump transmission is currently in pump gear
Auxiliary Brake - indicates secondary braking device is active

BLUE INDICATORS

High Beam indicator

AUDIBLE ALARMS

Air Filter Restriction
Cab Tilt Lock
Check Engine
Check Transmission
Open Door/Compartment
High Coolant Temperature
High or Low System Voltage
High Transmission Temperature
Low Air Pressure
Low Coolant Level
Low DEF Level
Low Engine Oil Pressure
Low Fuel
Stop Engine
Water in Fuel
Extended Left/Right Turn Signal On

ABS System Fault

BACKLIGHTING COLOR

The instrumentation gauges and the switch panel legends shall be backlit using white LED backlighting.

RADIO

There shall be four (4) speakers installed inside the cab. The speakers shall be provided for connection to a sound system installed by the body manufacturer. The speakers shall be installed with two (2) recessed overhead in the front portion of the cab rearward of the windshields and two (2) located on the upper rear wall of the cab. Wiring for the speakers shall be routed to the center dash area under the electrical access cover.

AM/FM ANTENNA

A small antenna shall be located on the left hand side of the cab roof for AM/FM and weather band reception.

CAMERA REAR

One (1) Audiovox Voyager heavy duty box shaped HD camera shall be shipped loose for OEM installation in the body to afford the driver a clear view to the rear of the vehicle.

The camera system shall include a one-way communication device that shall be an integral part of the rear camera for the use of voice commands directly to the driver. The rear camera display shall activate when the vehicle's transmission is placed in reverse.

CAMERA DISPLAY

The camera system shall be wired to a single Weldon Vista display located on the driver's side dash. The camera system display can be activated through the Vista display panel.

CAMERA SPEAKER

The rear camera shall be wired to speaker(s) in the cab and shall audible to the driver and officer. There shall be a virtual button provided on the Vista display and control panel to deactivate the speaker(s).

CAB EXTERIOR PROTECTION

The cab face shall have a removable plastic film installed over the painted surfaces to protect the paint finish during transport to the body manufacturer.

FIRE EXTINGUISHER

A 2.50 pound D.O.T approved fire extinguisher with BC rating shall be shipped loose with the cab.

ROAD SAFETY KIT

The cab and chassis shall include one (1) emergency road safety triangle kit.

DOOR KEYS

The cab and chassis shall include a total of four (4) door keys for the manual door locks.

DIAGNOSTIC SOFTWARE OCCUPANT PROTECTION

Diagnostic software for the Spartan Advanced Protection System shall be available for free download from the Spartan Chassis website to Spartan authorized OEMs, dealers and service centers, as well as the vehicle owner.

The software has been validated to be compatible with the following RP1210 interface adapters:

- Dearborn Group DPA4 Plus
- Noregon Systems JPRO® DLA+
- Cummins INLINE5
- Cummins INLINE6
- NexIQ™ USB-Link™

The software and adapter utilize the SAE J1939-13 heavy duty nine (9) pin connector which is located below the driver's side dash to the left of the steering column.

WARRANTY

Purchaser shall receive a Custom Chassis Three (3) Years or 48,000 Miles limited warranty in accordance with, and subject to, warranty certificate RFW0103. The warranty certificate is incorporated by reference into this proposal, and included with this proposal or available upon request.

CHASSIS OPERATION MANUAL

There shall be two (2) digital copies of the chassis operation manual provided with the chassis. The digital data shall include a parts list specific to the chassis model.

ENGINE AND TRANSMISSION OPERATION MANUALS

The following manuals specific to the engine and transmission models ordered will be included with the chassis in the ship loose items:

- (1) Hard copy of the Engine Operation and Maintenance manual with digital copy
- (1) Digital copy of the Transmission Operator's manual
- (1) Digital copy of the Engine Owner's manual

CAB/CHASSIS AS BUILT WIRING DIAGRAMS

The cab and chassis shall include two (2) digital copies of wiring schematics and option wiring diagrams.

PAINT CONFIRMATION

There shall be a paint confirmation letter sent to the body manufacturer with paint spray outs to confirm the cab primary paint color or primary and secondary paint color as specified by the paint options.

SALES TERMS

The sale of the chassis shall be governed by the terms contained on the Sales Terms – Acceptance of Purchase Order document, a copy of which is attached to this option.

DRIVELINE LAYOUT CONFIRMATION

During the design phase of the chassis the Spartan Chassis driveline engineer shall submit the driveline layout to an OEM engineer to review the chassis design for any potential problems integrating the OEM body to the chassis. The OEM engineer shall provide approval to the driveline engineer prior to driveline bills of materials being released.

CHASSIS MODIFICATIONS

LUBRICATION AND TIRE DATA PLATE

A permanent label in the driving compartment shall specify the quantity and type of the following fluids used in the vehicle and tire information:

- Engine oil
- Engine coolant
- Chassis transmission fluid
- Pump transmission lubrication fluid . . (if applicable)
- Pump priming system fluid, if applicable . . (if applicable)
- Drive axle(s) lubrication fluid
- Air conditioning refrigerant . . (if applicable)
- Air conditioning lubrication oil . . (if applicable)
- Power steering fluid
- Cab tilt mechanism fluid . . (if applicable)
- Transfer case fluid . . (if applicable)
- Equipment rack fluid (if applicable)
- CAFS air compressor system lubricant . . (if applicable)
- Generator system lubricant . . (if applicable)
- Front tire cold pressure
- Rear tire cold pressure
- Maximum tire speed ratings

VEHICLE DATA PLATE

A permanent label in the driving compartment which indicates the following:

- Filter part numbers for the;
 - Engine
 - Transmission
 - Air
 - Fuel
- Serial numbers for the;
 - Engine
 - Transmission
- Delivered Weights of the Front and Rear Axles
- Paint Brand and Code(s)
- Sales Order Number

OVERALL HEIGHT, LENGTH DATA PLATE (US)

The fire apparatus manufacturer shall permanently affix a high-visibility label in a location visible to the driver while seated.

The label shall show the height of the completed unequipped vehicle in feet and inches (meters), the length of the completed vehicle in feet and inches (meters to nearest 1/10th), and the GVWR in tons (metric tons).

Wording on the label shall indicate that; "The information shown was current when the apparatus was manufactured. If the overall height changes while the vehicle is in service, the fire department must revise that dimension on the plate".

PERSONNEL CAPACITY

A label that states the number of personnel the vehicle is designed to carry shall be located in an area visible to the driver.

SEAT BELT WARNING - FAMA06/07

A safety sign FAMA06 shall be visible from each seat that is not equipped with occupant restraint and therefore not intended to be occupied while the vehicle is in motion.

A safety sign FAMA07, which warns of the importance of seat belt use, shall be visible from each seat that is intended to be occupied while the vehicle is in motion.

EQUIPMENT MOUNTING FAMA10

A safety sign FAMA10, which warns of the need to secure items in the cab, shall be visible inside the cab.

FIRE SERVICE TIRES - FAMA12

A safety sign FAMA12, which warns of the special requirements for fire service-rated tires, shall be visible to the driver entering the cab of any apparatus so equipped.

HELMET WARNING - FAMA15

A safety sign FAMA15, which warns not to wear helmets while the vehicle is in motion, shall be visible from each seat that is intended to be occupied while the vehicle is in motion.

CLIMBING METHOD - FAMA23

A safety sign FAMA23, which warns of the proper climbing method, shall be visible to personnel entering the cab and at each designated climbing location on the body.

REAR STEP CROSSWALK WARNING - FAMA24

A safety sign FAMA24, which warns personnel not to ride on the vehicle, shall be located at the rear step areas and at any cross walkways.

FINAL STAGE MANUFACTURER VEHICLE CERTIFICATION

A final stage manufacturer vehicle certification label shall be provided and installed in the driver cab door jamb area.

FRONT BUMPER

The front bumper shall be provided by the cab/chassis manufacturer.

FRONT BUMPER EXTENSION

The front bumper of the chassis shall be extended approximately 28" ahead of the cab using structural steel channel.

The bumper mounting plate shall be welded to the structural steel channel for mounting of the chassis bumper. After fabrication of the bumper extension, the panels shall be removed and the unit shall be primed and painted black.

RESCUE BUMPER COMPARTMENT

The front bumper shall have a 28" extension with **two (2)** individual compartments. **One (1)** compartment shall be provided **curbside**, outboard of the chassis frame rails capable of storing one (1) low pressure air hose reel on curbside. The **floor** of the outboard **compartment** shall be sloped to increase the angle of approach. One (1) compartment shall be located in center of extension located between the chassis frame rails to store Houston Fire Department portable **air driven** pump. **Streetside of bumper compartment interior shall of the same material and level as the remainder of the gravel shield.**

A 6.5" high single lid shall cover **the** compartments fabricated from 1/8" NFPA compliant aluminum tread plate with stainless steel hinges, chrome lift handle, **one (1)** stainless steel "butterfly" type latches, and two (2) gas shock type hold open devices, one (1) at each end. A "Not a Step" label shall be provide on outer lid surface.

Bumper compartment shall have one (1) OnScene 36" Access LED lights mounted to light inside the compartment area to provide a minimum of 2 fc (20 lx) at any location on the floor of the compartment without any equipment in the compartment. Light shall be automatically activated when door is opened. A flashing warning light signal shall be provided indicating when parking brake is released that a compartment door is not in a closed position as required by NFPA 1901.

The following shall be located in the bumper:

- **Houston Fire Department supplied and installed air driven offload pump**
- **SVI supplied and installed Hannay Reel, air reel air supply controls and rewind.**
- One (1) Hannay EF1514-17-18 low pressure air hose reel(s) shall be provided in this compartment. Reel shall be designed to hold 110% of the capacity needed.
 - Power rewind control(s) shall be in a position where the operator can observe the rewinding operation and not be more than 72 in. (1830 mm) above the operator's standing position, and shall be marked with a label indicating its function and shall be guarded to prevent accidental operation.
 - A label shall be provided in a visible location adjacent to reel with following information: (1) Utility air or breathing air, (2) Operating pressure, (3) Total hose length, (4) Hose size (ID).
 - The hose reel shall equipped with 100' of 3/8" Parker Series 7092 GST II low pressure air hose rated for 300 PSI maximum pressure. A molded plastic ball clamp shall be provided on the hose to stop it at the 4-way roller. The hose shall be Red in color with blue color coded end.
 - The non-emergency air supply shall be from auxiliary air side of the cab chassis air brake system. The air circuit shall be equipped with a pressure protection valve (PPV) to protect air brake system from loss of pressure from tool usage. (Note: Per NFPA 24.12.1, The chassis air brake system shall not be used for emergency use applications such as airbags, tools, air reels, and other rescue applications).

- A reel shut-off valve, 0 - 125 psi adjustable low pressure regulator, and 0 - 300 psi gauge shall be provided on an aluminum control panel with flow diagram graphic overlay near the air reel location, not exceeding 72" from ground.
- The fairlead roller shall be mounted directly to the reel.

AIR HORN(S)

Air horn(s) if specified shall be supplied and installed by the cab/chassis manufacturer.

MOTOR DRIVEN SIREN

There shall be a Federal model Q2BP motor driven streamlined rotary siren with chrome plated grill and housing, pedestal mounted on extended front bumper. The siren shall be wired through the master warning light switch, and properly wired with heavy copper cable for minimum voltage drop.

The siren shall be located on the streetside of the front bumper. **Move inboard from previous unit to reduce/eliminate overhanging the front corner.**

The siren brake if specified shall be installed by the cab/chassis manufacturer.

SIREN ACTIVATION

The siren activation shall be provided by cab/chassis manufacturer.

FRONT TOW PROVISIONS

The front tow provisions if specified shall be supplied and installed by the cab/chassis manufacturer.

GROUND LIGHTS

There shall be two (2) OnScene 8" Access white LED lights installed below bumper capable of providing illumination at a minimum level of 2 fc (20 lx) on ground areas within 30 in. (800 mm) of the edge of the vehicle in areas designed for personnel to climb onto or descend from the vehicle to the ground level.

Lighting shall be switchable but activated automatically when the vehicle park brake is set.

AIR INTAKE SYSTEM

An air filter shall be provided in the engine's air intake system by the customer cab/chassis manufacturer.

Air inlet restrictions shall not exceed the engine manufacturer's recommendations.

The air inlet shall be equipped with a means of separating water and burning embers from the air intake system.

This requirement shall be permitted to be achieved by either of the following methods:

1. Provision of a device such that burning particulate matter larger than 0.039 in. (1.0 mm) in diameter cannot reach the air filter element.

2. Provision of a multi screen ember separator capable of meeting the test requirements defined in the Parker Hannafin, Racor Division, publication LF 1093-90, *Ember Separation Test Procedure*, or an equivalent test.

EXHAUST

The exhaust system shall be as provided by cab/chassis manufacturer.

AM/FM RADIO INSTALL

There shall be one (1) AM/FM Stereo supplied and installed in the streetside component console (left hand position) in rear cab area.

SCUFF PANELS

Stainless steel scuff protection shall be provided behind cab mounted shore power plugs near driver door.

RADIO ANTENNA INSTALLATION

There shall be four (4) Houston Fire Department supplied radio(s) with antenna installed in the cab command area. There shall be a total of one (1) radio, and three (3) remote radio heads.

All required radio programming shall be responsibility of Houston Fire Department. Radio(s) may not be fully tested if no radio program is provided with radio and will be responsibility of Houston Fire Department after delivery. Radios shall be installed per Manufacturer's requirements and wired for proper 12 volt power and ground.

Label all four radios to correspond with David Clark command station. Radio "A" will be in the front cab dash, and radios "B" and "C", and "D" will be in the command area as specified by corresponding console specifications. Label the cables to match the radios and they should also be positioned A, B, C, D, from left to right.

Four (4) individual external speakers, one (1) per specified radio above shall be provided with separate volume controls. Radio "A" speaker centered on overhead climate control cover, radio "B" speaker located under streetside overhead cabinet, Radio "C" & radio "D" located under curbside overhead cabinet.

Antenna base units shall be under the desk (behind driver and officer seats) on mounting panels.

Do not install Dash Radio/Siren Microphone

NO CIMA RADIO on this unit. Install a blank faceplate.

See later Change Order for Radio Layout and Clarifications.

TIRE PRESSURE VISUAL INDICATORS

Tire pressure visual indicators if specified shall be supplied by the cab and chassis manufacturer.

CAB PAINT

The finish paint and color as provided from the cab/chassis manufacturer shall be provided. Cab shall not be repainted.

(Note: Most departments do NOT find that the fleet paint finish from a commercial cab/chassis manufacturer is acceptable. The Body Builder will NOT be responsible for paint quality and finish issues.)

CAB INTERIOR COMPONENT PAINT COLOR, OEM SUPPLIED

Powder coat shall be hammertone black. Cardinal T013-BK62

SST CAB FENDERETTES

The cab wheel wells shall be finished with SST fenderettes.

HUB AND NUT COVERS

Front and rear wheels shall be provided with stainless steel hub caps and wheel nut covers.

MUDFLAPS

There shall be 1/4" rubber mudflaps with logo provided and installed behind each set of tires to prevent throwing road debris and lower road spray.

AIR BRAKE SYSTEM QUICK BUILD-UP

The air brake quick build-up system shall be supplied from the specified automatic electric compressor in order to maintain full operating air pressure while the vehicle is not running.

The quick buildup system shall provide sufficient air pressure so that the apparatus has no brake drag and is able to stop under the intended operating conditions following the 60-second buildup time.

CHASSIS AIR TANK DRAIN CABLES

The cab/chassis air brake system tank drains cables shall be extended to panel(s) located on forward streetside lower body or as per tank locations. Each air tank drain cable shall be extended/routed to the panel(s) through eyelets so as to prevent cables hanging or being exposed below the body.

Each pull ring/handle shall be properly labeled to identify each tank and include a black colored label bezel.

REAR CAB COMPONENT LAYOUT

The following components shall be provided in the rear area of cab, final layout to be determined at pre-construction meeting.

REAR CAB DESK - STRAIGHT

The rear portion of the cab shall be provided with a desktop which shall be approximately 26" deep x 85" long and located approximately 30" from floor. The desk top surface shall be fabricated of 3/16" smooth finish aluminum.

There shall be 2-1/2" diameter holes with plastic edge grommet provided at each rear corner for wiring of future equipment located on the desk top.

DESKTOP COMPONENT CONSOLE

There shall be a two (2) console(s) at top rear of the desk for optional component mounting. The console(s) shall be fabricated from 1/8" aluminum approximately 6" high x 9" deep with a 6" sloping component mounting face.

The sloped component mounting surface shall be a one-piece cover to allow access to optional components, and wiring and held closed with fastener in each corner.

- There shall be four (4) communications radio and/or siren 3" recess mount(s) with black powdercoat paint finish in specified console.
- There shall be two (2) 120 VAC, 20 amp, duplex straight-blade receptacle (NEMA 5-20R) outlet(s) provided in specified console.
 - Outlet(s) shall be powered by both the on-board generator and shore power system through a relay system.
- There shall be two (2) Blue Sea 12 VDC USB dual port(s) provided in specified console.
- There shall be one (1) 120 VAC outlet(s) located under desk against the back edge.
 - The outlet receptacle(s) shall be 20 amp, straight-blade (NEMA 5-20R).
 - Outlet(s) shall be powered through the on-board generator system.
- There shall be two (2) Blue Sea Systems ST series blade type fuse block(s) with screw type terminals for both positive and negative buss with cover provided for distribution of up to six (6) 30 amp, 12 VDC circuits.
- The fuse block shall be protected by a 60 amp maxi fuse located at the source.
- Fuse block shall be wired battery direct.
- Fuse block shall be located on the top left and right, below desk.

FILING CABINET, 2-DRAWER

One (1) Hon 2-drawer Efficiency Pedestal cabinet(s) with "K" type pull handles shall be provided under specified desk areas. Cabinet(s) shall have a keyed lock and shall be painted charcoal. Each filing cabinet shall be approximately 15" wide x 27" high x 20" deep. Both drawers of the cabinet shall be capable of storing 8-1/2" x 11" file folders.

INTERIOR PEDESTAL SEAT, 3-POINT ABTS

Two (2) Bostrom Sierra high back reclining ABTS seat(s) shall be provided. Seat(s) shall have swivel pedestal base with 3 locking positions, and 5" fore/aft adjustment. Seat(s) shall be securely mounted to the reinforced floor structure.

The Bostrom seat(s) shall include a covering of extra high strength, wear resistant fabric made of durable Durawear Plus™ ballistic polyester. A PVC coating shall be bonded to the back side of the material to help protect the seats from UV rays and from being saturated or contaminated by fluids. The material meets FMVSS 302 flammability requirements. Seats material color shall closely match the cab chassis supplied seat colors.

The seat(s) shall feature an all belts to seat (ABTS) style of safety restraint. The ABTS feature shall include a three-point shoulder harness with the lap belt and automatic retractor as an integral part of the seat assembly. Belts shall be red in color. The buckle portion of the seat belt shall extend from the seat base towards the occupants position within easy reach of the occupant. The ABTS feature shall also include the RiteHite™ shoulder adjustment feature to provide enhanced comfort and safety by allowing customized seat belt fit.

Each seat shall be wired to the on-board seat belt indicator, and Vehicle Data Recorder (VDR) systems per NFPA 1901.

CAB INTERIOR CABINET - OVERHEAD

There shall be two (2) rear facing overhead cabinet(s) provided on interior. Each cabinet shall be constructed of 1/8" smooth finish aluminum approximately 14" high x 14" deep x 26" wide. If cab is specified with air bags, the interior cabinet(s) will be mounted clear of the deployment area.

The above cabinet(s) shall have lift-up type door(s) framed from 80/20 Inc. aluminum extrusions, rounded corners, and gas piston type door stays. The door shall have a dry-erase outer surface.

Cabinet door shall have a winged cam latch mechanism to hold door in closed position. Cabinet door latch required per NFPA 1901 in areas occupied while vehicle is in motion.

- There shall be two (2) Blue Sea Systems ST series blade type fuse block(s) with screw type terminals for both positive and negative buss with cover provided for distribution of up to six (6) 30 amp, 12 VDC circuits.
- The fuse block shall be protected by a 60 amp maxi fuse located at the source.
- Fuse block shall be wired battery direct.
- Fuse block shall be located in the top left interior corner.

INTERIOR UNDER CABINET LED LIGHTS

Two (2) OnScene Solution model #70152, 10" x 6" x 7/8", 10-30 VDC, surface mount dual red and white LED light(s) with clear lens shall be provided under cabinet. Each light shall be individually switched with a high/low intensity setting. In addition light(s) will be capable of a five (5) second delay after switching off.

CAB INTERIOR CABINET - STREETSIDE OVERHEAD

There shall be one (1) overhead cabinet(s) provided on interior. Cabinet(s) shall be constructed of 1/8" smooth finish aluminum. Each cabinet shall be approximately 14" high x 14" deep, length to best fit the designated area. If cab is specified with air bags, the interior cabinet(s) will be mounted clear of the deployment area.

The above cabinet(s) shall have lift-up type door(s) framed from 80/20 Inc. aluminum extrusions, rounded corners, and gas piston type door stays. The door shall have a dry-erase outer surface.

Cabinet door shall have a winged cam latch mechanism to hold door in closed position. Cabinet door latch required per NFPA 1901 in areas occupied while vehicle is in motion.

- There shall be one (1) Blue Sea Systems ST series blade type fuse block(s) with screw type terminals for both positive and negative buss with cover provided for distribution of up to six (6) 30 amp, 12 VDC circuits.
- The fuse block shall be protected by a 60 amp maxi fuse located at the source.
- Fuse block shall be wired battery direct.
- Fuse block shall be located in the top left interior corner.

INTERIOR UNDER CABINET LED LIGHTS

One (1) OnScene Solution model #70152, 10" x 6" x 7/8", 10-30 VDC, surface mount dual red and white LED light(s) with clear lens shall be provided under cabinet. Each light shall be individually switched with a high/low intensity setting. In addition light(s) will be capable of a five (5) second delay after switching off.

CAB MISCELLANEOUS EQUIPMENT

The following items shall be provided in cab as follows;

MAGNETIC WHITEBOARD

There shall be one (1) magnetic whiteboard(s), approximately 72" wide x 45" tall located on rear cab wall.

CAB STREETSIDE WINDOW

There shall be one (1) 50" wide x 26" high, double-paned insulated, horizontal sliding window(s) installed. The window shall slide open towards the front of the vehicle such that wind pressure would tend to shut the window. Each window shall have tinted automotive type safety glass mounted in an 1.5" extruded aluminum frame. The frame shall have a black anodized finish. Sliding style windows shall be complete with a sliding screen.

INTERIOR LED LIGHTS

Two (2) OnScene Solution model #70156, 10" x 10" x 7/8", 10-30 VDC, surface mount dual red and white LED light(s) with clear lens shall be provided on overhead center air conditioner plenum. In addition light(s) will be capable of a five (5) second delay after switching off.

The light(s) shall be switched with high/low intensity setting at the entry door(s). An Innovative Controls black back-lit switch panel shall be provided to control specified lighting or other control switching.

A power source relay shall be provided to allow ceiling lights power battery direct when shore line power connected.

120 VAC CAB OUTLETS

- There shall be one (1) 120 VAC outlet(s) located near filing cabinet for specified printer.
 - The outlet receptacle(s) shall be 20 amp, straight-blade (NEMA 5-20R).
 - Outlet(s) shall be powered by both the on-board generator and shore power system through a relay system.

ROOF MOUNTED AIR CONDITIONER

Two (2) Dometic Penguin II low profile, 120 VAC, 60 cycle, single phase air conditioner(s) shall be provided and installed on the cab roof. The unit shall be a roof top contemporary contoured integral evaporator/condenser type with built-in heating elements.

Each unit shall be rated at minimum of 13,500 BTU cooling capacity with a heating element rated at 5,600 BTU. A three-speed fan shall supply a maximum/minimum of 320/250 cfm air flow capacity. Air conditioner(s) shall be controlled by a wall mounted Comfort Control II LCD thermostat.

The roof mounted air conditioner shall be approximately 9.5" high x 29" wide x 40" long and weigh approximately 99 lbs.

SHORE POWER INLET

The 30A auto ejecting Inlet shall be listed in the electrical section of this specification.

- Chassis supplied/referenced inlet cover color shall be blue.

FUEL FILL

There shall be one (1) fuel fill door located in the streetside exterior wheel well panel, behind the rear axle. The fill door shall be fabricated from brushed stainless steel. There shall be a permanent label with the text "DIESEL FUEL ONLY" located adjacent to the fuel fill access.

A stainless steel scuff plate shall be provided below fuel fill door.

FUEL FILL

There shall be one (1) fuel fill door located in the curbside exterior wheel well panel, behind the rear axle. The fill door shall be fabricated from brushed stainless steel. There shall be a permanent label with the text "DIESEL FUEL ONLY" located adjacent to the fuel fill access.

A stainless steel scuff plate shall be provided below fuel fill door.

DEF FLUID FILL

The DEF fluid fill shall be as supplied by commercial cab/chassis manufacturer.

EXTERIOR ALUMINUM BODY

The fabrication of the body shall be constructed from aluminum 3003H-14 alloy smooth plate. This shall include compartment front panel, vertical side sheets, side upper rollover panels, rear panels and compartment door frames.

The body compartment floors and exterior panels shall be constructed with not less than 3/16" (.187) aluminum 3003H-14 smooth plate. Interior compartment dividing walls shall be constructed with not less than 1/8" (.125) aluminum 3003H-14 smooth plate. Lighter gauge sheet metal will not be acceptable in these areas, No Exceptions.

The front and rear corners of body shall be formed as part of the front or rear body panels. This provides a stronger body corner and finished appearance. The use of extruded corners, or caps will not be acceptable, No Exceptions.

The door side frame openings shall be formed "C" channel design. An electrical wiring conduit raceway running the full length of exterior compartments shall be provided. This raceway shall contain all 12 volt wiring running to the rear of the apparatus, permitting easy accessibility to wiring.

Individual compartment modules, with dead air space voids between compartments, will not be an acceptable method of compartment construction.

The compartments shall be an integral part of the body construction. Compartment floors from front of body to ahead of rear axle, also from rear axle to rear of body shall be single one-piece sections. Compartment floors shall be preformed, then positioned in body and welded into final position.

Compartment floors shall have a "sweep-out" design with door opening threshold positioned lower than compartment floor, permitting easy cleaning of compartments. Angles, lips, or door moldings are not acceptable in the base of compartment door opening. One-way rubber drain valves shall be provided in compartment floors so that a water hose may be used to flush-out compartment area.

All exterior seams in sheet metal below frame, and around the rear wheel well area shall be welded and caulked to resist moisture from entering the compartments. All other interior seams and corners shall be sealed with silicone based caulk prior to painting.

Only stainless steel bolts, nuts, and sheet metal screws shall be used in mounting exterior trim, hardware and equipment.

Exterior compartments shall have louvers in lower back wall of compartment for ventilation.

DRIP RAILS

Same as previous 2 units, stick on.

~~The body shall have drip rails over the side full height compartments. The drip rails shall be formed into the upper body panels providing a ridged lower panel and a flat upper body panel surface. The use of mechanically fastened, taped or glued on drip rails will not be acceptable. No Exceptions.~~

10" REAR STEP BUMPER

The full width rear bumper shall be constructed from 2" x 2" x 1/4" aluminum tubing frame and covered with 3/16" NFPA compliant aluminum tread plate. The bumper shall extend from the rear vertical body panel 10" and provide a rear step with a minimum of 1/2" space at body for water drainage.

REAR TOW EYES

There shall be two (2) heavy duty rear mounted tow eyes securely attached to the body subframe, below body. The tow eyes shall be fabricated from 3/4" thick steel plate with a 3" diameter opening. Tow eyes shall have a black powder coat finish.

GROUND LIGHTS

10"

There shall be two (2) OnScene 8" Access white LED lights installed below bumper capable of providing illumination at a minimum level of 2 fc (20 lx) on ground areas within 30 in. (800 mm) of the edge of the vehicle in areas designed for personnel to climb onto or descend from the vehicle to the ground level.

Lighting shall be switchable but activated automatically when the vehicle park brake is set.

WHEEL WELL EXTERIOR PANEL

The exterior panel of the body wheel well enclosure shall be constructed from 3/16" smooth aluminum panels.

STAINLESS STEEL BODY FENDERETTES

The body wheel well openings shall be provided with round radius, polished stainless steel fenderettes. The fenderettes shall be bolted and easily replaceable if damaged. The fenderettes shall be installed using a rubber gasket to reduce buildup of moisture and/or debris.

WHEEL WELL LINERS

The wheel wells shall be provided with an easily removable polymer, circular inner fender liner. The inner liner shall be bolted to the wheel well with stainless steel bolts and spaced away from the wheel well so the liner will not accumulate dirt or water.

SCBA CYLINDER COMPARTMENTS

Two (2) SCBA cylinder storage compartments shall be provided, one (1) each side of the body in rear wheel well area. Each compartment shall have a stainless steel hinge with brushed stainless steel door assembly with a positive catch latch. Each compartment shall have a 8" diameter tube behind the wheel well panel attached to the door assembly. Each compartment shall allow the storage of an SCBA cylinder or a fire extinguisher up to 7-3/4" in diameter x 22" deep. The door shall activate the "Hazard Warning Light" in the cab when not in the closed position.

PAINT FINISH - SINGLE COLOR

The body shall be painted with a single color of PPG Delfleet® Evolution per Houston Fire Department approved paint spray out provided.

- Paint Color: Match cab/chassis supplied paint color.

BODY UNDERCOATING

The entire underside of body shall be sprayed with black automotive undercoating. Undercoating shall cover all areas underside of body and wheel well area to help resist corrosion under the vehicle.

COMPARTMENT INTERIOR FINISH

The interior of all exterior body compartments shall be a "Maintenance Free" smooth unpainted finish. All body seams shall be finished with a caulk sealant for both appearance and moisture protection.

CHEVRON STRIPE - CAB BUMPER

A reflective stripe shall be affixed to the front of cab. The stripe or combination of stripes shall be a minimum of 4 in. (100 mm) in total width.

The approximate 10" wide Chevron retroreflective stripe shall be affixed to at least 25 percent of the width of the front of the apparatus with retroreflective striping in a chevron pattern sloping downward and away from the centerline of the vehicle at an angle of 45 degrees. Each stripe shall be 6" width. Chevron panels shall have a 3M UV over laminate to protect from UV rays, scene damage, and everyday use. Chevron panels shall have a minimum 10 year warranty for material failure, and colorfastness.

- The stripe material shall be 3M Scotchlite Diamond Grade.

All retroreflective materials required shall conform to the requirements of ASTM D 4956, *Standard Specification for Retroreflective Sheeting for Traffic Control*, Section 6.1.1 for Type I Sheeting.

This reflective chevron stripe shall alternate red and fluorescent yellow-green in color.

REFLECTIVE STRIPE - CAB DOOR INTERIOR

Any door of the apparatus designed to allow persons to enter or exit the apparatus shall have at least 96 in.2 (62,000 mm2) of retroreflective material affixed to the inside of the door 2" above bottom of door.

The inside of each cab and crew doors shall have 4" Chevron style diamond grade reflective striping. The colors shall be red and fluorescent yellow-green.

Company decal shall be provided within interior door panel chevron panel.

CHEVRON REFLECTIVE STRIPE - REAR SIDES PANELS

At least 50 percent of the rear-facing vertical surfaces, visible from the rear of the apparatus, excluding any pump panel areas not covered by a door, shall be equipped with retroreflective striping in a chevron pattern sloping downward and away from the centerline of the vehicle at an angle of 45 degrees. Each stripe shall be 6" width.

The rear side panels of the body on each side of a rear stairway or compartment shall have a chevron style reflective stripe, extending from bumper to full body height. Each chevron panel shall be a full sheet and shall have a 3M UV over laminate to protect from UV rays, scene damage, and everyday use. Chevron panel shall have a minimum 10 year warranty for material failure, and colorfastness.

The stripe material shall be 3M Diamond Grade.

This reflective chevron stripe shall alternate red and fluorescent yellow-green in color.

LETTERING

No lettering shall be provided on the completed unit.

EXTERIOR COMPARTMENT DOORS

FLUSH FITTING HINGED DOOR CONSTRUCTION

The exterior compartment doors shall be a flush style, custom manufactured and built for each compartment. The compartment doors must be able to withstand years of rugged service and wear. For this reason, the compartment door design, metal thickness, and attachments must be strictly adhered to.

ROLL-UP DOOR CONSTRUCTION - ROBINSON (ROM)

The vehicle shall be equipped with R•O•M Series IV roll-up exterior compartment doors. The R•O•M roll-up doors shall be complete with the following features;

STREETSIDE COMPARTMENT - FRONT (S1) UPPER

The upper interior useable compartment width shall be approximately 35.5" wide.

The compartment door opening shall be approximately 28.0" wide.

- This compartment shall have a flush fitting horizontally hinged, drop-down style compartment door. The door exterior shall be painted job color.
- The compartment door opening shall be approximately wide.
- The interior door panel shall have a smooth un-painted aluminum panel.
- The hinged door(s) shall have a stainless steel 6" offset bent D-ring non-locking handle. A gasket shall be placed between handle and door. Door latches shall be a two-point rotary slam, double-catch latch, recessed inside the double panel door with striker plate.
- The hinged door(s) shall have a pair of tailgate style mechanisms to stop the door at 90 degrees. Each door shall be capable of being closed without unlatching.
- The door shall be equipped with a CPI harsh environment mechanical type door ajar switch located inside compartment interior to activate compartment lighting and door ajar signal in cab when door is opened.

COMPARTMENT LAYOUT

- There shall be one (1) OnScene Solutions 83 series aluminum tray base with 70% extension, and rating of 1,000 lbs. Slide-out tray(s) base shall be full width (street/curb) and as wide as the compartment layout or door opening permits, capable of extending out either side of the body located above the level of the chassis frame rails. Each slide base shall have a cable operated, spring loaded latch complimented by a large hand opening and red pull handle (Pull to Release) which will lock the tray in the closed, 40% extended and 70% extended positions.
 - Equipment storage module shall be provided on slide-out tray base providing storage for Houston Fire Department equipment. The module shall be 3/16" (.188) 3003H-14 alloy smooth aluminum sheet.

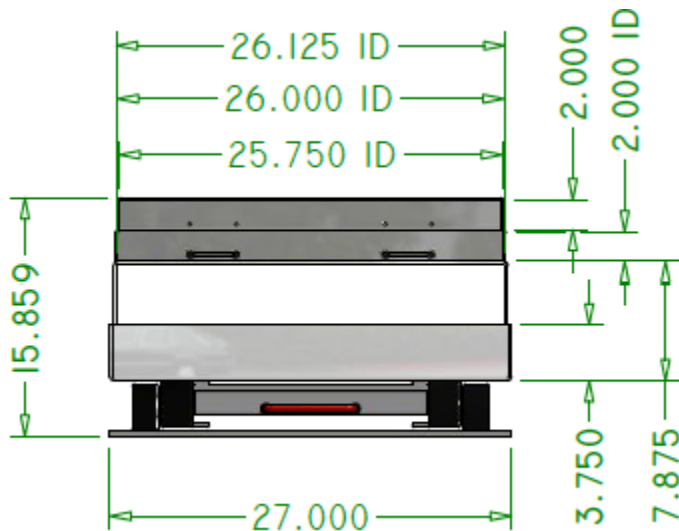

- There shall be four (4) OnScene Solutions Velcro cargo straps provided to secure the stored equipment.
- The above component(s) shall have a smooth un-painted finish.
- 3M™ Diamond Grade™ 2" wide conspicuity striping shall be provided on the front and side faces of the tray.

STREETSIDE COMPARTMENT - FRONT (S1) LOWER

The interior useable compartment width shall be approximately 64.5" wide.

The compartment door opening shall be approximately 57.0" wide.

- This compartment shall have a flush fitting horizontally hinged, drop-down style compartment door. The door exterior shall be painted job color.
- The compartment door opening shall be approximately wide.
- The interior door panel shall have a smooth un-painted aluminum panel. **Overlaid with 1/4" HDPE Poly Sheet.**
- The hinged door(s) shall have a stainless steel 6" offset bent D-ring non-locking handle. A gasket shall be placed between handle and door. Door latches shall be a two-point rotary slam, double-catch latch, recessed inside the double panel door with striker plate.
- The hinged door(s) shall have a pair of tailgate style mechanisms to stop the door at 90 degrees. Each door shall be capable of being closed without unlatching.
- The door shall be equipped with a CPI harsh environment mechanical type door ajar switch located inside compartment interior to activate compartment lighting and door ajar signal in cab when door is opened.

COMPARTMENT LAYOUT

- One (1) OnScene Access white LED mounted at the top of the compartment toward the door opening.
- There shall be one (1) 120 VAC outlet(s) located in compartment.
 - The outlet receptacle(s) shall be 20 amp, straight-blade (NEMA 5-20R).
 - Outlet(s) shall be powered through the on-board generator system.
 - The outlet shall be located on forward wall, upper left area. **Match Previous Unit.**
- One (1) OnScene 8" Access white LED ground light(s) shall be provided below the body. Light(s) shall be switchable but activated automatically when the park brake is set.

STREETSIDE COMPARTMENT - AHEAD OF REAR WHEELS (S2)

The interior useable compartment width shall be approximately 64.5" wide.

- This compartment shall have a flush fitting horizontally hinged, drop-down style compartment door. The door exterior shall be painted job color.
- The compartment door opening shall be approximately wide.
- The interior door panel shall have a smooth un-painted aluminum panel. Opening for generator ventilation shall be provided.
- The hinged door(s) shall have a stainless steel 6" offset bent D-ring non-locking handle. A gasket shall be placed between handle and door. Door latches shall be a two-point rotary slam, double-catch latch, recessed inside the double panel door with striker plate.
- The hinged door(s) shall have a pair of tailgate style mechanisms to stop the door at 90 degrees. Each door shall be capable of being closed without unlatching.
- The door shall be equipped with a CPI harsh environment mechanical type door ajar switch located inside compartment interior to activate compartment lighting and door ajar signal in cab when door is opened.

COMPARTMENT LAYOUT

- One (1) OnScene Access white LED mounted at the top of the compartment toward the door opening.
- The hydraulic driven generator location.
- One (1) OnScene 8" Access white LED ground light(s) shall be provided below the body. Light(s) shall be switchable but activated automatically when the park brake is set.
- Two (2) 3-1/2" x 3-1/2" black plastic louvered vents shall be provided in the lower compartment.

STREETSIDE COMPARTMENT - REAR (S3)

The interior useable compartment space shall be approximately 70.5" wide.

- This compartment shall have a R•O•M series IV roll-up door.
- The compartment door opening shall be approximately wide.
- The roll-up door slats and the door track components shall be painted to match the single tone exterior color.
- The door shall be equipped with a CPI harsh environment mechanical type door ajar switch located inside compartment interior door track to activate compartment lighting and door ajar signal in cab when door is opened.
- There shall be NO keyed lock on this roll-up compartment door.
- One (1) 1" wide elastic nylon strap shall be provided to assist in closing the compartment door. The strap shall be fastened to the lower left inside door sill with a nickel plated Footman loop secured to back of door. The strap shall extend from door to a nickel plated Footman loop secured to wall or vertical slot of Shelf-Trac on left side of the door opening.
- One (1) aluminum drip pan/door guard shall be provided below door roll area. Drip pan/door guard shall have thumb nuts making it easily removable without tools with a maintenance-free, un-painted finish. A plastic drain line shall be provided on each end of the drip pan to lower door threshold.
- Compartment threshold protection shall be provided on the bottom edge of the compartment door sill. The threshold protection shall be an extruded aluminum shape with an un-painted anodized finish.

COMPARTMENT LAYOUT

- There shall be vertically mounted aluminum Shelf-Trac welded to compartment walls for specified component installation. Shelf-Trac extrusion shall have side extruded channels for use in mounting or securing special ancillary items, without need for drilling into body.
- There shall be two (2) adjustable shelf/shelves approximately 30" deep aft of vertical partition. Each shelf shall be fabricated from 3/16" 3003 aluminum sheet with a 2" vertical flange along the front and rear edges.
 - The above component(s) shall have a smooth un-painted finish.
- There shall be two (2) vertical compartment partition(s) provided dividing the compartment into fore and aft sides. The vertical partition(s) shall be 3/16" (.188) 3003H-14 alloy smooth aluminum sheet.
 - The above component(s) shall have a smooth un-painted finish.
- Storage provision shall be provided forward of specified vertical partition for Houston Fire Department 85 gallon hazmat overpack drum. One (1) ratchet strap shall be provided to secure Hazmat drum.

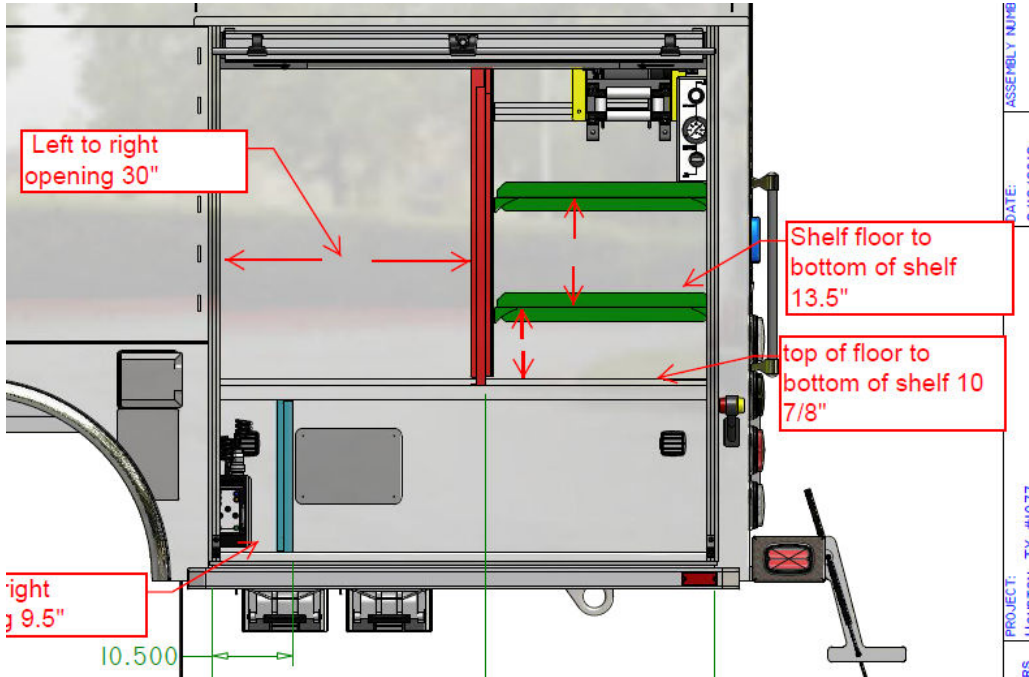

- The floor of the compartment above the frame rails shall be extended to the interior edge of the door. The floor shall have a 2" vertical lip and a 1" return to increase strength.
- One (1) Hannay EF1514-17-18 low pressure air hose reel(s) shall be provided in this compartment. Reel shall be designed to hold 110% of the capacity needed.
 - Power rewind control(s) shall be in a position where the operator can observe the rewinding operation and not be more than 72 in. (1830 mm) above the operator's standing position, and shall be marked with a label indicating its function and shall be guarded to prevent accidental operation.
 - A label shall be provided in a visible location adjacent to reel with following information: (1) Utility air or breathing air, (2) Operating pressure, (3) Total hose length, (4) Hose size (ID).
 - The hose reel shall equipped with 100' of 3/8" Parker Series 7092 GST II low pressure air hose rated for 300 PSI maximum pressure. A molded plastic ball clamp shall be provided on the hose to stop it at the 4-way roller. The hose shall be Red in color with blue color coded end.
 - The non-emergency air supply shall be from auxiliary air side of the cab chassis air brake system. The air circuit shall be equipped with a pressure protection valve (PPV) to protect air brake system from loss of pressure from tool usage. (Note: Per NFPA 24.12.1, The chassis air brake system shall not be used for emergency use applications such as airbags, tools, air reels, and other rescue applications).
 - A reel shut-off valve, 0 - 125 psi adjustable low pressure regulator, and 0 - 300 psi gauge shall be provided on an aluminum control panel with flow diagram graphic overlay near the air reel location, not exceeding 72" from ground.
- The fairlead roller shall be mounted directly to the reel.

- Two (2) OnScene Access white LED, full height compartment lights, vertically mounted.
- The controls for the specified light tower(s).
- One (1) OnScene 8" Access white LED ground light(s) shall be provided below the body. Light(s) shall be switchable but activated automatically when the park brake is set.
- Two (2) 3-1/2" x 3-1/2" black plastic louvered vents shall be provided in the lower compartment.

CURBSIDE COMPARTMENT - FRONT (C1) UPPER

The upper interior useable compartment width shall be approximately 35.5" wide.

The compartment door opening shall be approximately 28.0" wide.

- This compartment shall have a flush fitting horizontally hinged, drop-down style compartment door. The door exterior shall be painted job color.
- The compartment door opening shall be approximately wide.
- The interior door panel shall have a smooth un-painted aluminum panel.
- The hinged door(s) shall have a stainless steel 6" offset bent D-ring non-locking handle. A gasket shall be placed between handle and door. Door latches shall be a two-point rotary slam, double-catch latch, recessed inside the double panel door with striker plate.
- The hinged door(s) shall have a pair of tailgate style mechanisms to stop the door at 90 degrees. Each door shall be capable of being closed without unlatching.
- The door shall be equipped with a CPI harsh environment mechanical type door ajar switch located inside compartment interior to activate compartment lighting and door ajar signal in cab when door is opened.

COMPARTMENT LAYOUT

- There shall be vertically mounted aluminum Shelf-Trac welded to compartment walls for specified component installation. Shelf-Trac extrusion shall have side extruded channels for use in mounting or securing special ancillary items, without need for drilling into body.
- There shall be one (1) OnScene Solutions 83 series aluminum tray base with 70% extension, and rating of 1,000 lbs. Slide-out tray(s) base shall be approximately 94" deep; capable of extending out either side of the body located above the level of the chassis frame rails. (Specified in opposite side compartment.)
- 3M™ Diamond Grade™ 2" wide conspicuity striping shall be provided on the front and side faces of the tray.
- One (1) OnScene Access white LED mounted at the top of the compartment toward the door opening.
- The cab chassis supplied cab tilt control pendant shall be **mounted to upper** forward wall. **Permanently mounted.**

CURBSIDE COMPARTMENT - FRONT (C1) LOWER

The interior useable compartment width shall be approximately 45.5" wide.

The compartment door opening shall be approximately 38.5" wide.

- This compartment shall have a flush fitting horizontally hinged, drop-down style compartment door. The door exterior shall be painted job color.
- The compartment door opening shall be approximately wide.
- The interior door panel shall have a smooth un-painted aluminum panel. **Overlaid with 1/4" HDPE Poly Sheet.**
- The hinged door(s) shall have a stainless steel 6" offset bent D-ring non-locking handle. A gasket shall be placed between handle and door. Door latches shall be a two-point rotary slam, double-catch latch, recessed inside the double panel door with striker plate.
- The hinged door(s) shall have a pair of tailgate style mechanisms to stop the door at 90 degrees. Each door shall be capable of being closed without unlatching.
- The door shall be equipped with a CPI harsh environment mechanical type door ajar switch located inside compartment interior to activate compartment lighting and door ajar signal in cab when door is opened.

COMPARTMENT LAYOUT

- One (1) OnScene Access white LED mounted at the top of the compartment toward the door opening.
- There shall be one (1) 120 VAC outlet(s) located in compartment.
 - The outlet receptacle(s) shall be 20 amp, straight-blade (NEMA 5-20R).
 - Outlet(s) shall be powered through the on-board generator system.
 - The outlet shall be located on forward wall, upper left area. **Match Previous Unit.**
- One (1) OnScene 8" Access white LED ground light(s) shall be provided below the body. Light(s) shall be switchable but activated automatically when the park brake is set.

SIDE ENTRY DOOR

Access shall be provided to the interior through a single side entry door with a clear door opening width of approximately 28.5".

Construction of the side entry door shall be with 1/8" aluminum exterior smooth plate and painted exterior body color choice. The interior door pan shall be constructed from 1/8" aluminum treadplate.

The door shall be hung on full height 14 gauge stainless steel hinge, with a 1/4" stainless steel pin. The hinge shall be bolted to the door and body with stainless steel machine screws at offset 5" centers. The hinge shall be slotted horizontally and vertically for ease of adjustment. A polyester barrier film gasket shall be placed between the stainless steel hinge and door.

Full width padded foam cushion head bumper shall be provided above door opening. The head bumper shall be covered with matching interior vinyl and bolted to interior of door way.

The door latch mechanism shall include a stainless steel paddle type handle on interior. A polyester barrier film gasket shall be placed between the stainless steel handles and the aluminum door panels. The door latch shall be a double catch two-point safety slam latch recessed inside the double panel door with strike plate mounted top and bottom of door frame complying with FMVSS requirements.

- The hinged door(s) shall have a stainless steel 6" offset bent D-ring locking handle. A gasket shall be placed between handle and door. Door latches shall be a two-point rotary slam, double-catch latch, recessed inside the double panel door with striker plate.
- One (1) OnScene 8" Access white LED ground light(s) shall be provided below the body. Light(s) shall be switchable but activated automatically when the park brake is set.

ENTRY HANDRAILS

There shall be two (2) handrails provided at entry door; one (1) 24" vertical on exterior of body on door handle side, and one (1) 30" on inside of door. The interior handrail shall be angled for optimum use when entering or exiting the interior body area.

Handrails shall be 3-piece NFPA compliant 1-1/4" aluminum.

A safety sign FAMA23, which warns of the proper climbing method, shall be visible to personnel entering the cab and at each designated climbing location on the body.

A safety sign FAMA24, which warns personnel not to ride on the vehicle, shall be located at the rear step areas and at any cross walkways.

ELECTRIC STEP

One (1) Ziamatic Quic-Step 3094 VS-24 series, 12 volt electric folding step(s) shall be provided and installed under the entry door(s). The step shall fold out and down to reduce the ground to step distance. The step shall be 24" wide and constructed with a cast aluminum step plate with a non-skid surface to provide traction and safety.

Step shall be wired into door interlock system to automatically extend with door opening and retract with door closing.

POWER STEP SWITCHING

There shall be a momentary switch on interior walkway adjacent to side door to override electric step activation regardless of door position. Step shall be interlocked with parking brake so that step will always be retracted with brake disengaged and operate normally (dependent on door position) when parking brake reset.

WINDOW(S)

There shall be one (1) 18" wide x 22" high, double-paned insulated, non-sliding window(s) installed in the entrance door. Each window shall have tinted automotive type safety glass mounted in an extruded aluminum frame. The frame shall have a black anodized finish.

WINDOW(S)

There shall be one (1) 18" wide x 22" high, double-paned insulated, vertical sliding window(s) installed in the entrance door. Each window shall have tinted automotive type safety glass mounted in an extruded aluminum frame. The frame shall have a black anodized finish.

CURBSIDE COMPARTMENT - AHEAD OF REAR WHEEL (C2)

The interior useable compartment width shall be approximately 48.0" wide.

The compartment door opening shall be approximately 40.5" wide.

- This compartment shall have a flush fitting horizontally hinged, drop-down style compartment door. The door exterior shall be painted job color.
- The compartment door opening shall be approximately wide.
- The interior door panel shall have a smooth un-painted aluminum panel. **Overlaid with 1/4" HDPE Poly Sheet.**
- The hinged door(s) shall have a stainless steel 6" offset bent D-ring non-locking handle. A gasket shall be placed between handle and door. Door latches shall be a two-point rotary slam, double-catch latch, recessed inside the double panel door with striker plate.
- The hinged door(s) shall have a pair of tailgate style mechanisms to stop the door at 90 degrees. Each door shall be capable of being closed without unlatching.
- The door shall be equipped with a CPI harsh environment mechanical type door ajar switch located inside compartment interior to activate compartment lighting and door ajar signal in cab when door is opened.

COMPARTMENT LAYOUT

- One (1) OnScene Access white LED mounted at the top of the compartment toward the door opening.
- One (1) OnScene 8" Access white LED ground light(s) shall be provided below the body. Light(s) shall be switchable but activated automatically when the park brake is set.
- Two (2) 3-1/2" x 3-1/2" black plastic louvered vents shall be provided in the lower compartment.

CURBSIDE COMPARTMENT - REAR (C3)

The interior useable compartment space shall be approximately 70.5" wide.

- This compartment shall have a R•O•M series IV roll-up door.
- The compartment door opening shall be approximately wide.
- The roll-up door slats and the door track components shall be painted to match the single tone exterior color.
- The door shall be equipped with a CPI harsh environment mechanical type door ajar switch located inside compartment interior door track to activate compartment lighting and door ajar signal in cab when door is opened.
- There shall be NO keyed lock on this roll-up compartment door.
- One (1) 1" wide elastic nylon strap shall be provided to assist in closing the compartment door. The strap shall be fastened to the lower left inside door sill with a nickel plated Footman loop secured to back of door. The strap shall extend from door to a nickel plated Footman loop secured to wall or vertical slot of Shelf-Trac on left side of the door opening.
- One (1) aluminum drip pan/door guard shall be provided below door roll area. Drip pan/door guard shall have thumb nuts making it easily removable without tools with a maintenance-free, un-painted finish. A plastic drain line shall be provided on each end of the drip pan to lower door threshold.
- Compartment threshold protection shall be provided on the bottom edge of the compartment door sill. The threshold protection shall be an extruded aluminum shape with an un-painted anodized finish.

COMPARTMENT LAYOUT

- There shall be vertically mounted aluminum Shelf-Trac welded to compartment walls for specified component installation. Shelf-Trac extrusion shall have side extruded channels for use in mounting or securing special ancillary items, without need for drilling into body.
- **USE SHALLOW SHELF-TRAC.**
- There shall be three (3) adjustable shelf/shelves approximately 30" deep. Each shelf shall be fabricated from 3/16" 3003 aluminum sheet with a 2" vertical flange along the front and rear edges.
 - The above component(s) shall have a smooth un-painted finish.
 - 3M™ Diamond Grade™ Conspicuity striping shall be provided on the front face of the shelf(s).
- There shall be one (1) OnScene Solutions 81 series aluminum tray base with rating of 1,000 lbs. Slide-out tray(s) base shall be approximately 24" deep and as wide as the compartment layout or door opening permits located below the level of the chassis frame rails. Slide base shall extend depth specified, less 4". Each slide base shall have a cable operated, spring loaded latch complimented by a large hand opening and red pull handle (Pull to Release) which will lock the tray in the closed and full extension positions.
 - The above component(s) shall have a smooth un-painted finish.

- 3M™ Diamond Grade™ 2" wide conspicuity striping shall be provided on the front and side faces of the tray.
- There shall be one (1) vertical compartment partition(s) provided dividing the compartment into fore and aft sides. The vertical partition(s) shall be 3/16" (.188) 3003H-14 alloy smooth aluminum sheet.
 - The above component(s) shall have a smooth un-painted finish.
- Three (3) vertically and horizontally adjustable storage rod(s) shall be provided for Houston Fire Department supplied roll(s) of absorbent material, plastic sheeting and plastic drum liner.

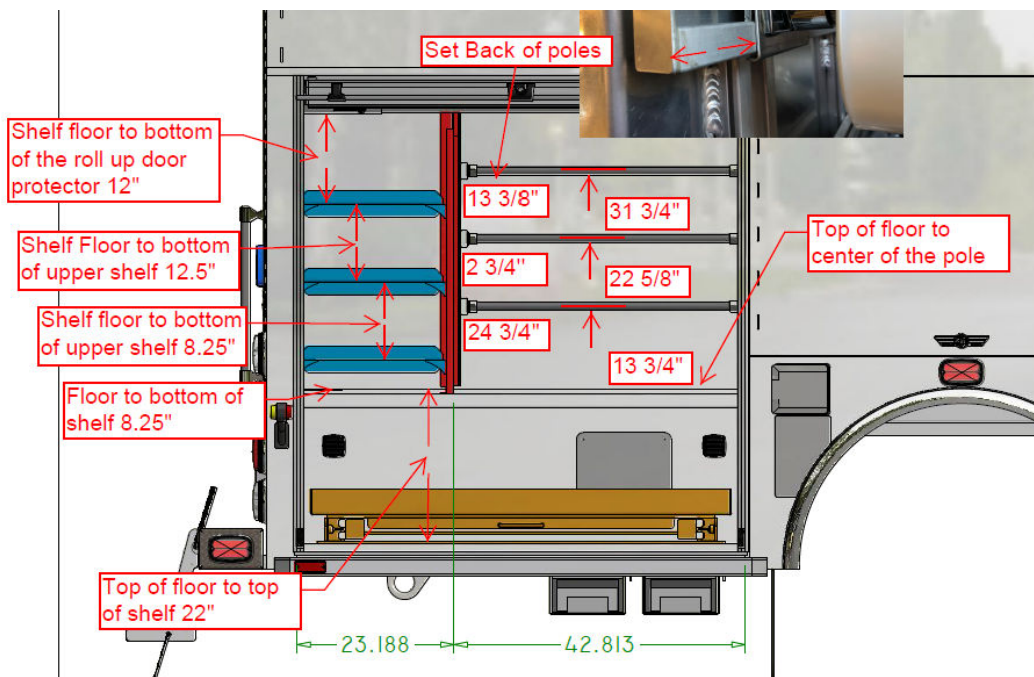

The floor of the compartment above the frame rails shall be extended to the interior edge of the door. The floor shall have a 2" vertical lip and a 1" return to increase strength.

- Two (2) OnScene Access white LED, full height compartment lights, vertically mounted.
- One (1) OnScene 8" Access white LED ground light(s) shall be provided below the body. Light(s) shall be switchable but activated automatically when the park brake is set.
- Two (2) 3-1/2" x 3-1/2" black plastic louvered vents shall be provided in the lower compartment.

REAR ENTRY DOOR

Access shall be provided to the interior through a single entry door with a clear door opening width of approximately 28.5" x full height.

Construction of the rear entry door shall be with 1/8" aluminum exterior smooth plate, the interior door pan shall be constructed from 1/8" aluminum treadplate.

The door shall be hung on full height 14 gauge stainless steel hinge, with a 1/4" stainless steel pin. The hinge shall be bolted to the door and body with stainless steel machine screws at offset 5" centers. The hinge shall be slotted horizontally and vertically for ease of adjustment. A polyester barrier film gasket shall be placed between the stainless steel hinge and door.

Full width padded foam cushion head bumper shall be provided above door opening. The head bumper shall be covered with matching interior vinyl and bolted to interior of door way.

The door latch mechanism shall include a stainless steel paddle type handle on interior. A polyester barrier film gasket shall be placed between the stainless steel handles and the aluminum door panels. The door latch shall be a double catch two-point safety slam latch recessed inside the double panel door with strike plate mounted top and bottom of door frame complying with FMVSS requirements.

- The hinged door(s) shall have a stainless steel 6" offset bent D-ring locking handle. A gasket shall be placed between handle and door. Door latches shall be a two-point rotary slam, double-catch latch, recessed inside the double panel door with striker plate.

ENTRY HANDRAILS

There shall be two (2) handrails provided at entry door; one (1) 24" vertical on exterior of body on door handle side, and one (1) 30" on inside of door. The interior handrail shall be angled for optimum use when entering or exiting the interior body area.

Handrails shall be 3-piece NFPA compliant 1-1/4" aluminum.

A safety sign FAMA23, which warns of the proper climbing method, shall be visible to personnel entering the cab and at each designated climbing location on the body.

A safety sign FAMA24, which warns personnel not to ride on the vehicle, shall be located at the rear step areas and at any cross walkways.

WINDOW(S)

There shall be one (1) 18" wide x 22" high, double-paned insulated, vertical sliding window(s) installed in the entrance door. Each window shall have tinted automotive type safety glass mounted in an extruded aluminum frame. The frame shall have a black anodized finish.

BODY OPTIONS AND UPGRADES

PLASTIC FLOOR AND SHELF TILE

Turtle Plastics 12" x 12" x 1/2", self-draining plastic inter-locking material shall be cut to size and cover all compartment floors, shelves, and trays.

- The plastic floor tile shall be black.
- The plastic edge trim shall be black.

LOWER SIDE BODY PROTECTION - RUB RAIL

OnScene Solutions rub rails shall be provided below the compartment door openings on both the streetside and curbside.

3M™ Diamond Grade™ Conspicuity striping shall be provided in the rub rail. The striping shall be red/white in color.

WALK-IN INTERIOR FINISH DETAILS

DESK, CABINET, CONSOLE FINISH

All specified interior desks, cabinets, overhead cabinets, or consoles shall be fabricated from formed 1/8" 3003 H14 alloy smooth aluminum.

INTERIOR COMPONENT FINISH

After fabrication is completed all specified desk(s) or cabinet(s) shall be painted with a hammer tone powder coat paint finish for a hard durable surface.

Powder coat shall be quartz grey. Cardinal T243-GR301

INTERIOR SPECIFICATIONS

INTERIOR INSULATION

Following the sheet metal fabrication the roof area, upper exterior walls and the entry door of the apparatus body shall be insulated with Dow Thermax, or equal.

INTERIOR FINISH

The interior finish shall be pearl gray pebble grain FRP.

INTERIOR WALKWAY FLOOR

There shall be Lonseal, Loncoin-II Flecks installed on the floor substrate. Loncoin II Flecks is a heterogeneous resilient sheet vinyl with a decorative raised coin texture, breathtaking color, and intriguing style. The fleck coloration provides camouflage for simpler maintenance while the raised coin embossing provides enhanced traction. Excellent for interior, retail, commercial, or institutional use where design parameters call for a high performance, sophisticated flooring solution.

Loncoin II Flecks is composed of polyvinyl chloride (PVC) resin, plasticizers, fillers, and pigments. The co-calendared wear layer is formulated to provide maximum resistance to foot traffic and most commercial and healthcare chemicals.

The middle layer provides dimensional stability, sound-absorbing properties, and resiliency under foot. The backing layer provides strength and stability of the flooring and enhances the bonding strength of the adhesive.

The material shall be black in color (Loncoin-II Flecks - Onyx).

Lonseal, Inc. warrants that Lonseal flooring products shall be free from manufacturing defects for a period of one (1) year from the date of purchase and that, when properly installed and maintained, shall not wear through as a result of normal foot traffic for a period of 7 years from the date of installation.

INTERIOR SUB-FLOOR

Above the body sub frame walk in areas shall be an isolation sheet to prevent outside elements from permeating the acoustic and thermal barrier. The isolation sheet shall be fabricated from the same type of material as is used in the subframe, and flanged on sides with a 1" high vertical break.

3/4" thick plywood shall be placed between the isolation sheet and finished floor for its structural, acoustic and thermal values.

AIR CONDITIONER - HEATER

Three (3) Dometic Penguin II low profile, 120 VAC, 60 cycle, single phase air conditioner(s) shall be provided and installed on roof of vehicle. The unit shall be a roof top contemporary contoured integral evaporator/condenser type with built-in heating elements.

Each unit shall be rated at minimum of 13,500 BTU cooling capacity with a heating element rated at 5,600 BTU. A three-speed fan shall supply a maximum/minimum of 320/250 cfm air flow capacity. Air conditioner(s) shall be controlled by a wall mounted Comfort Control II LCD thermostat.

The roof mounted air conditioner shall be approximately 9.5" high x 29" wide x 40" long and weigh approximately 99 lbs.

- The above rooftop Air Conditioning units shall be powered by both the generator and shore power

FRONT INTERIOR AREA (IF1)

MAGNETIC WHITEBOARD

There shall be one (1) magnetic whiteboard(s) located on front walk-in area wall, full width between counter top and overhead cabinets.

HAND TOOL CABINET

One (1) Lista drawer cabinet, model HS-0900 series shall be provided centered at front walk-in area in compartment. The Lista cabinet(s) shall be 40-1/4" wide x 39.3/8" high x 22-1/2" deep. Cabinet shall have five (5) individual locking drawers as follows as follows; two (2) 2", one (1) 3", one (1) 5", and one (1) 7". The cabinet shall be Light Gray in color.

- There shall be two (2) interior counter height cabinet(s) provided, one (1) on streetside, and one (1) on curbside of forward interior. Cabinet(s) shall be constructed of 1/8" smooth finish aluminum, and painted with a hammer tone powder coat paint finish for a hard durable surface. Paint color shall be white. Each cabinet shall be approximately 26.0" wide x 27.5" high..
- Cabinet(s) shall be provided with vertically mounted shallow aluminum Shelf-Trac for specified component installation.
 - The above cabinet(s) shall have an open front face (no door).
- Cabinet(s) shall be provided with vertically mounted shallow aluminum Shelf-Trac for specified component installation.
- There shall be two (2) vertically adjustable shelf in each of the above cabinets. It shall have a 1.25" lip to contain items while minimizing space used.

INTERIOR CABINET - WORK SURFACE

There shall be a work surface installed above the specified cabinet(s). The work surface shall be fabricated with 1/8" thick smooth aluminum, and painted with a hammer tone powder coat paint finish for a hard durable surface. Paint color shall be gray.

- There shall be two (2) approximately 42" wide x 14" high x 14" deep overhead cabinet(s) provided on interior. Cabinet(s) shall be constructed of 1/8" smooth finish aluminum, and painted with a hammer tone powder coat paint finish for a hard durable surface.
- Four (4) evenly spaced vertical divders shall be bolted to floor of streestide cabinet.
- The above cabinet(s) shall have lift-up type door(s) with dry-erase outer surface.

Each cabinet door shall have one (1) winged cam latch mechanism to hold door in closed position. Cabinet door latch required per NFPA 1901 in occupied areas while vehicle is in motion.

INTERIOR UNDER CABINET LED LIGHTS

Two (2) OnScene Solution model #70152, 10" x 6" x 7/8", 10-30 VDC, surface mount dual red and white LED light(s) with clear lens shall be provided under cabinet. Each light shall be individually switched with a high/low intensity setting. In addition light(s) will be capable of a five (5) second delay after switching off.

120 VAC CABINET OUTLETS

- There shall be four (4) 120 VAC outlet(s) located, two (2) in streetside, and **two (2)** in curbside cabinets against the back wall.
 - The outlet receptacle(s) shall be 20 amp, straight-blade (NEMA 5-20R).
 - Outlet(s) shall be powered by both the on-board generator and shore power system through a relay system.

- Three (3) Houston Fire Department supplied gas monitor chargers shall be mounted in IF1 overhead cabinet streetside.



- The interior smooth aluminum deck area or cabinet over exterior side body compartments {will/shall} be provided with plastic interlocking grating. The grating {will/shall} be easily removable, maintenance-free and not subject to mechanical damage.

CIRCULATING FAN

There shall be two (2) 12 VDC circulating fan(s) provided and located in the walk-in area of body or in cab. Each fan shall have a switch on the base of the fan.

DESK 12 VDC FUSE BLOCK

- There shall be one (1) Blue Sea Systems ST series blade type fuse block(s) with screw type terminals for both positive and negative buss with cover provided for distribution of up to six (6) 30 amp, 12 VDC circuits.
- The fuse block shall be protected by a 60 amp maxi fuse located at the source.
- Fuse block shall be wired battery direct.
- Fuse block shall be located in the top left, above work counter.
- There shall be one (1) 120 VAC outlet(s) located above desk in each corner against the back wall.
 - The outlet receptacle(s) shall be 20 amp, straight-blade (NEMA 5-20R).
 - Outlet(s) shall be powered by both the on-board generator and shore power system through a relay system.
- Four (4) Streamlight Fire Vulcan C4 LED flashlight(s) with shoulder strap shall be provided with 80,000 candela and 3 hour run time. Each flashlight shall be orange in color and have a 12 volt DC charger and vehicle mount kit. Each flashlight shall have an LED spotlight style bulbs and reflectors. The flashlight(s) shall be wired to battery direct unless otherwise specified by Houston Fire Department.
 - Four (4) flashlight(s) shall be mounted on the curbside wall above work top.

STREETSIDE INTERIOR AREA (IS1)

- The apparatus 12 volt electrical distribution panel shall be located in the front portion of the interior streetside wall directly across from the side access door.
- The area directly behind the front interior area cabinets and Lista Tool Box will be an open floor area approximately 94" wide x 24" deep.

STREETSIDE INTERIOR AREA (IS2)

- There shall be two (2) Zico 1000 series KD-UH walkaway type SCBA air pack bracket(s) for Scott AP75 1 hour cylinders with high cycle coated spring clips and angled foot plate (no CRS strap inc.) mounted on front of IS1 full height cabinet.
- There shall be two (2) full height cabinet(s) provided on interior. Cabinet(s) shall be constructed of 1/8" smooth finish aluminum, and painted with a hammer tone powder coat paint finish for a hard durable surface. Paint color shall be white. Each cabinet shall be approximately 45" wide x 75" high x 24" deep.
- Cabinet(s) shall be provided with vertically mounted shallow aluminum Shelf-Trac for specified component installation.
- Cargo netting of 1" - 2" nylon webbing shall be provided over forward cabinet opening only with automotive seatbelt style latches.
- Cabinet(s) shall be provided with vertically mounted shallow aluminum Shelf-Trac for specified component installation.
- There shall be four (4) vertically adjustable shelf in each of the above cabinets. It shall have a 1.25" lip to contain items while minimizing space used.
- **Shelves in the deeper (non-cargo net) streetside/curbside cabinets shall have depth added to make their face flush with the face of the cabinets.**

STREETSIDE INTERIOR AREA (IS3)

- There shall be one (1) full height cabinet(s) provided on interior. Cabinet(s) shall be constructed of 1/8" smooth finish aluminum, and painted with a hammer tone powder coat paint finish for a hard durable surface. Paint color shall be gray. **Note:** There will be a 3" lip on the floor of the compartment to secure gear. Each cabinet shall be approximately 30" wide x 75" high x 24" deep.
- Cabinet(s) shall be provided with vertically mounted shallow aluminum Shelf-Trac for specified component installation.
- There shall be two (2) "J" style rope or equipment hook(s) for mounting of electrical extension cords or rescue ropes.
 - The above cabinet(s) shall have an open front face (no door).
- Cabinet(s) shall be provided with vertically mounted shallow aluminum Shelf-Trac for specified component installation.
- There shall be one (1) vertically adjustable shelf in each of the above cabinets. It shall have a 1.25" lip to contain items while minimizing space used.
- **Shelves in the deeper (non-cargo net) streetside/curbside cabinets shall have depth added to make their face flush with the face of the cabinets.**

STREETSIDE INTERIOR AREA (IS4)

INTERIOR WALKWAY SIDE WALLS

Walkway side walls from floor level to top of exterior compartments shall be aluminum tread plate panels.

- There shall be one (1) cabinet(s) provided on interior above the interior deck surface formed by exterior compartment ceilings. Cabinet(s) shall be framed in from the top of the interior deck surface to the ceiling of the walk-in area. Each cabinet shall be approximately 70" wide x 27" high x 30" deep.
- Cabinet(s) shall be provided with vertically mounted shallow aluminum Shelf-Trac for specified component installation.
- Cargo netting of 1" - 2" nylon webbing shall be provided over cabinet opening with automotive seatbelt style latches.

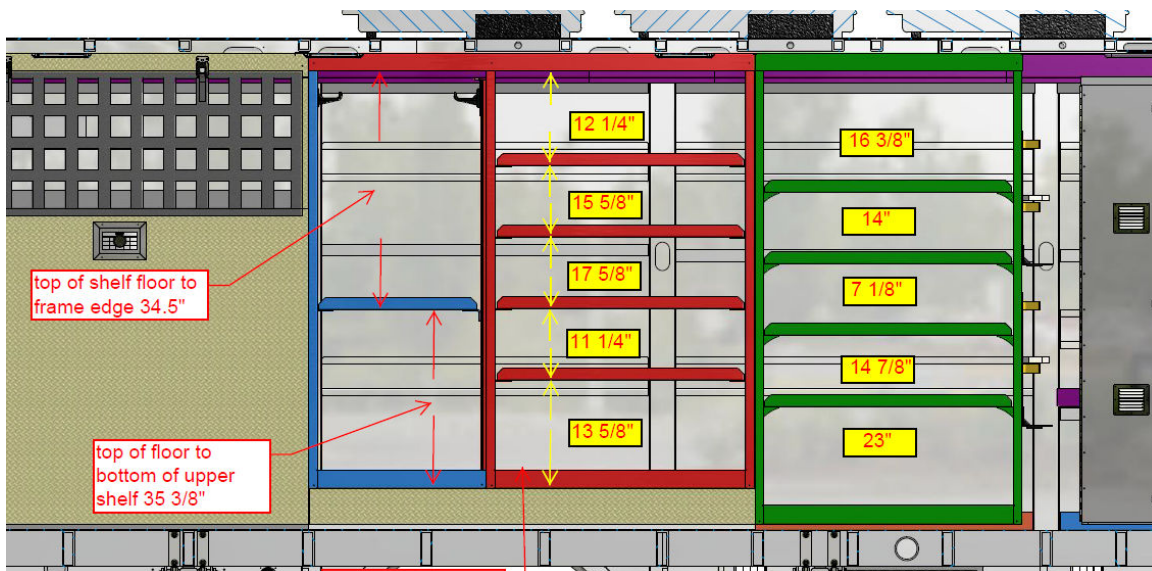

CURBSIDE INTERIOR AREA (IC1)

There shall be a side entry door located in this area.

CURBSIDE INTERIOR AREA (IC2)

- 120/240 VAC load center location.
- The generator gauge panel.
- There shall be one (1) interior counter height cabinet(s) provided on interior. Cabinet(s) shall be constructed of 1/8" smooth finish aluminum approximately (insert actual dimensions).
- ~~Cabinet(s) shall be provided with vertically mounted shallow aluminum Shelf-Trac for specified component installation.~~

- There shall be one (1) 400 lbs. slide-out tray(s) approximately 24" deep and located rearward (right) side of cabinet with open face. The tray top shall be fabricated from 3/16" 3003 aluminum sheet with a 3" vertical lip and welded corners to form a box type tray surface. The sliding tracks shall extend 100% of the slide length. The tray assembly shall utilize a pneumatic cylinder mounted on underside to hold the tray in both the extended and closed positions.
 - Vertical partition(s) shall be provided on slide-out tray base dividing the tray into left and right sides with gusset. The vertical partition(s) shall be 3/16" (.188) 3003H-14 alloy smooth aluminum sheet.
 - There shall be two (2) Zico 1000 series KD-UH walkaway type SCBA air pack bracket(s) for Scott AP75 1-hour cylinders with high cycle coated spring clips and angled foot plate (no CRS strap inc.) located one each side of partition.
 - The above component(s) shall have a smooth un-painted finish.
- There shall be one (1) SCBA cylinder storage module for 7-5/8" OD (maximum) SCBA bottles. The maximum length of the SCBA cylinder shall be 24.75". The module shall have an exterior shell fabricated from 1/8" (.125) 3003H-14 aluminum alloy sheet. The module shall have a 2" slope, front to back to prevent cylinders from sliding out. The SCBA cylinder storage tubing shall be fabricated from PVC pipe to resist damage or abrasion to cylinders. In addition there shall be rubber pad provided in the base of each storage tube for bottle protection and to resist slipping.
 - The SCBA cylinder module shall be capable of storing six (6) SCBA cylinders up to 7-5/8" diameter.
 - The above cabinet(s) shall have a 4" x 4" toe kick area at the base to allow for the top surface to be used as a working surface.
- The above cabinet(s) shall have a vertically hinged aluminum door(s) with a Southco push-release style latches and painted with a hammer tone powder coat paint finish to match cabinet color choice. Door shall be provided on forward (left) side of compartment approximately 18" wide.

INTERIOR CABINET - WORK SURFACE

There shall be a work surface installed above the specified cabinet(s). The work surface shall be fabricated with 1/8" thick smooth aluminum, and painted with a hammer tone powder coat paint finish for a hard durable surface. Paint color shall be gray.

- There shall be one (1) approximately 42" wide x 14" high x 14" deep overhead cabinet(s) provided on interior. Cabinet(s) shall be constructed of 1/8" smooth finish aluminum, and painted with a hammer tone powder coat paint finish for a hard durable surface.
- The above cabinet(s) shall have lift-up type door(s) with dry-erase outer surface.

Each cabinet door shall have one (1) winged cam latch mechanism to hold door in closed position. Cabinet door latch required per NFPA 1901 in occupied areas while vehicle is in motion.

INTERIOR UNDER CABINET LED LIGHTS

One (1) OnScene Solution model #70152, 10" x 6" x 7/8", 10-30 VDC, surface mount dual red and white LED light(s) with clear lens shall be provided under cabinet. Each light shall be individually switched with a high/low intensity setting. In addition light(s) will be capable of a five (5) second delay after switching off.

- There shall be one (1) Blue Sea Systems ST series blade type fuse block(s) with screw type terminals for both positive and negative buss with cover provided for distribution of up to twelve (12) 30 amp, 12 VDC circuits.
- The fuse block shall be protected by a 60 amp maxi fuse located at the source.
- Fuse block shall be wired battery direct.
- Fuse block shall be located on wall right side, above worktop.
- There shall be one (1) 120 VAC outlet(s) located at back of counter top.
- There shall be one (1) 120 VAC, 20 amp custom fabricated outlet strip provided with five (5) 20 amp duplex outlets.
 - The outlet receptacle(s) shall be 20 amp, straight-blade (NEMA 5-20R).
 - Outlet(s) shall be powered by both the on-board generator and shore power system through a relay system.

CURBSIDE INTERIOR AREA (IC3)

- There shall be two (2) full height cabinet(s) provided on interior. Cabinet(s) shall be constructed of 1/8" smooth finish aluminum, and painted with a hammer tone powder coat paint finish for a hard durable surface. Paint color shall be white. Each cabinet shall be approximately 31.5" wide x 75" high x 24" deep.
- Cabinet(s) shall be provided with vertically mounted shallow aluminum Shelf-Trac for specified component installation.
 - The above cabinet(s) shall have an open front face (no door).
- Cabinet(s) shall be provided with vertically mounted shallow aluminum Shelf-Trac for specified component installation.
- There shall be four (4) vertically adjustable shelf in each of the above cabinets. It shall have a 1.25" lip to contain items while minimizing space used.
- **Shelves in the deeper (non-cargo net) streetside/curbside cabinets shall have depth added to make their face flush with the face of the cabinets.**

CURBSIDE INTERIOR AREA (IC4)

INTERIOR WALKWAY SIDE WALLS

Walkway side walls from floor level to top of exterior compartments shall be aluminum tread plate panels.

- There shall be one (1) cabinet(s) provided on interior above the interior deck surface formed by exterior compartment ceilings. Cabinet(s) shall be framed in from the top of the interior deck surface to the ceiling of the walk-in area. Each cabinet shall be approximately 70" wide x 27" high x 30" deep.
- Cabinet(s) shall be provided with vertically mounted shallow aluminum Shelf-Trac for specified component installation.
- Cargo netting of 1" - 2" nylon webbing shall be provided over cabinet opening with automotive seatbelt style latches.

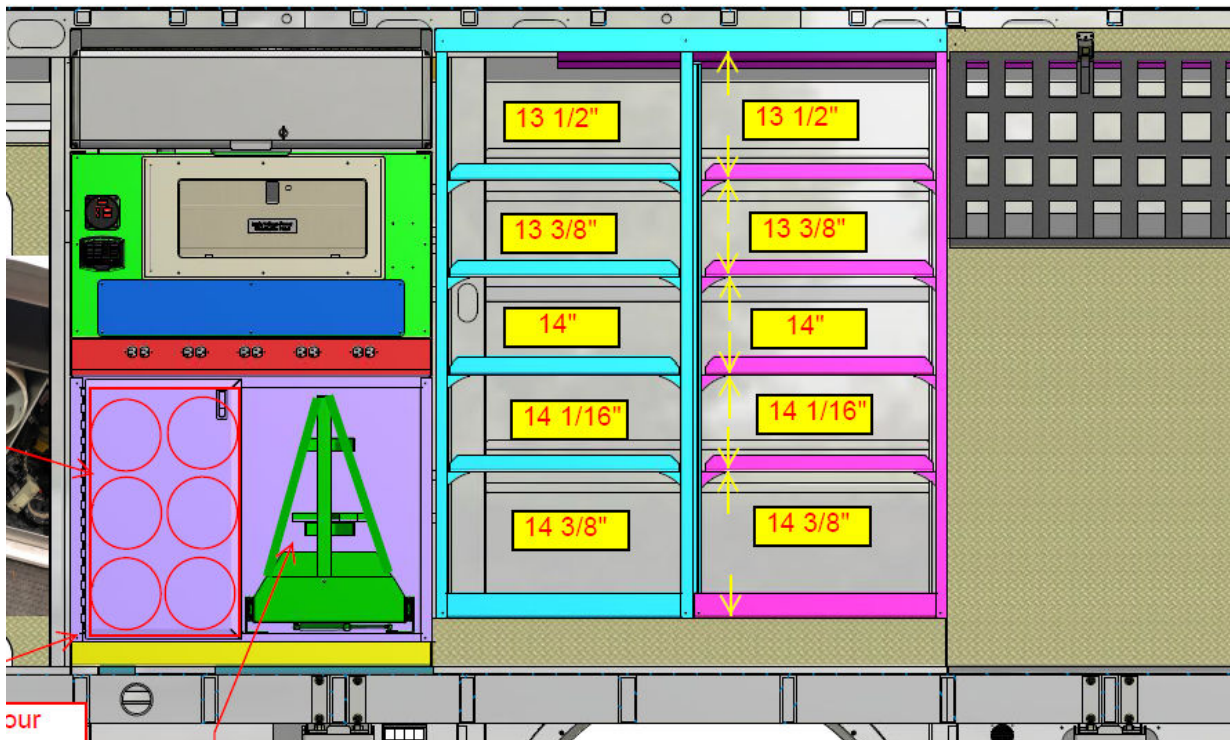

LOW VOLTAGE ELECTRICAL SYSTEM- 12 VDC

12 VOLT MULTIPLEX CONTROL CENTER

The apparatus shall be equipped with a Weldon V-MUX multiplexed 12 volt electrical system that will provide complete diagnostic capability, No Exception. The system shall have the capability of delivering multiple signals via a CAN bus, utilizing specifications set forth by SAE J1939. The system shall be node based to maximize stability so that failure of one node does not affect the operation of the other nodes. The system shall use shielded twisted-pair wire for transmission of system function signals. The shielded wire shall provide protection against EMI and RFI noise interruptions.

The multiplex system shall be responsible for providing power management functions as well as load shedding. The warning light system shall be controlled by the multiplex system. The system shall be capable of displaying text and/or graphic messages on a display module. The system shall be based on solid-state technology and shall include self-contained diagnostic indicators.

WELDON CERTIFICATION

A letter shall be provided with bid submittal that the Contractor has successfully completed the Weldon training requirements for Level 1 of the V-MUX Certified Supplier Program and is authorized to design, build, and service V-MUX electrical systems.

MULTIPLEX SYSTEM INTERFACE DISPLAY

The Weldon V-MUX Vista IV multiplex system interface display(s) shall be provided by the cab/chassis manufacturer. The full-color Vista interface display allows the user to control warning and scene lighting, HVAC controls (when specified), and view on-board diagnostics including service information. This display has a wide operating temperature range, automatic screen switching in response to current conditions, and a sleep mode option to eliminate night glare. The following features shall be included;

- 800 x 480 resolution
- Four video ports
- Flash updates with USB memory stick
- Display inside and outside temperature (when specified)
- Automatic climate control (when specified)
- 100% Configurable (OEM Level)
- Field re-programmable
- Peer to peer network
- On-board diagnostics / service information
- Colors change to indicate button status
- Video Ready for: Backup camera, Thermal camera, DVD, GPS...

SPECIAL PROGRAMMING

The VMUX programming for the VGT auxilliary engine brake control shall default to the last used control setting when the vehicle is shut off and restarted. This shall be programmed by SVI.

BATTERY SYSTEM

The battery connectors shall be heavy duty type with cables terminating in heat shrink loom. Heavy duty battery cables shall provide maximum power to the electrical system. Where required, the cables shall be shielded from exhaust tubing and the muffler. Large rubber grommets shall be provided where cables enter the battery compartment.

Batteries shall be of the high-cycle type. With the engine off, the battery system shall be able to provide the minimum continuous electrical load for 10 minutes without discharging more than 50 percent of the reserve capacity and then to restart the engine. The battery system cold cranking amps (CCA) rating shall meet or exceed the minimum CCA recommendations of the engine manufacturer. The batteries shall be mounted to prevent movement during fire apparatus operation and shall be protected against accumulations of road spray, snow, and road debris. The batteries shall be readily accessible for examination, testing, and maintenance.

A means shall be provided for jump-starting the engine if the batteries are not accessible without lifting the cab of a tilt-cab apparatus.

Where an enclosed battery compartment is provided, it shall be ventilated to the exterior to prevent the buildup of heat and explosive fumes. The batteries shall be protected against vibration and temperatures that exceed the battery manufacturer's recommendation.

An onboard battery conditioner or charger or a polarized inlet shall be provided for charging all batteries. Where an onboard conditioner or charger is supplied, the associated line voltage electrical power system shall be installed in accordance with Chapter 22.

One of the following master disconnect switches shall be provided:

- 1) A master body disconnect switch that disconnects all electrical loads not provided by the chassis manufacturer
- 2) A master load disconnect switch that disconnects all electrical loads on the apparatus except the starter

Electronic control systems and similar devices shall be permitted to be otherwise connected if so specified by their manufacturer.

The alternator shall be wired directly to the batteries through the ammeter shunt(s), if one is provided, and not through the master load disconnect switch.

A green "battery disconnect on" indicator light that is visible from the driver's position shall be provided.

Rechargeable hand lights, radios, and other similar devices shall be permitted to be connected to the electrical system ahead of the master disconnect switch.

A sequential switching device shall be permitted to energize the optical warning devices and other high current devices required in minimum continuous electrical load, provided the switching device shall first energize the electrical devices required in minimum continuous electrical load within 5 seconds.

BATTERY SWITCH

One (1) battery disconnect switch shall be provided in cab located within easy reach of driver with green indicator light that is visible from the driver's position. The switch and indicator light shall be supplied and installed by the cab/chassis manufacturer.

BATTERY SOLENOID

Battery switch shall consist of a minimum 200 ampere, constant duty solenoid to feed from positive side of battery.

BATTERY CONDITIONER

One (1) Kussmaul model Auto Charge LPC 40 single battery conditioner, with 120 VAC input and 40 amp, 12 volt output shall be provided. This system shall monitor the condition of batteries and provide an electrical current at variable rates to overcome battery failure.

CHASSIS AIR BRAKE PUMP

One (1) Kussmaul Auto-Pump 120 VAC, 100 psi air compressor shall be provided and installed to maintain air pressure in chassis air brake system. Compressor is factory set: 75 PSI "On", and 95 PSI "Off" with adjustment differential of 20 PSI. Pump shall be connected to battery charger circuit.

BATTERY CHARGE INDICATOR

A Kussmaul 091-94-12 charge indicator display shall be provided and located near drivers' door area. This single battery system indicator is a suppressed zero bar graph voltage display which may be installed in any 12 volt system.

Indicator will be install on face of dirver's seatbox aft of the compartment door.

SHORE POWER INLET

One (1) Kussmaul 120 VAC, 20 amp Super Auto-Eject shore power inlet(s) shall be provided. The shore power connection shall automatically disengage from vehicle when chassis ignition is engaged.

The protective ground from the shoreline inlet shall be bonded to the vehicle frame.

- The outlet cover shall be yellow.
- The shore power plug shall be located near the Driver door area.

ENGINE COMPARTMENT LIGHT

Engine compartment light(s) shall be supplied and installed by the cab chassis manufacturer.

CAB HAZARD WARNING LIGHT

A red flashing or rotating light, located in the driving compartment. The light shall be furnished by the cab/chassis manufacturer. The light shall be illuminated automatically whenever the vehicles parking brake is not fully engaged and any of the following conditions exist:

- Any passenger or equipment compartment door is not closed.
- Any ladder or equipment rack is not in the stowed position.
- Stabilizer system is not in its stowed position.
- Powered light tower is not stowed.
- Any other device permanently attached to the apparatus is open, extended, or deployed in a manner that is likely to cause damage to the apparatus if the apparatus is moved.

Compartments and equipment meeting all of the following conditions shall be permitted to be exempt from being wired to the hazard light:

- The volume is less than or equal to 4 ft³ (0.1 m³).
- The compartment has an opening less than or equal to 144 in.² (92,900 mm²).
- The open door does not extend sideways beyond the mirrors or up above the top of the fire apparatus.
- All equipment in the compartment is restrained so that nothing can fall out if the door is open while the apparatus is moving.
- Manually raised pole lights with an extension of less than 5 ft (1.5 m).

The hazard light shall be labeled "DO NOT MOVE APPARATUS WHEN FLASHING".

BACK-UP ALARM

An electronic back-up alarm shall be supplied and installed by the cab/chassis manufacturer. The back-up alarm shall actuate automatically when the transmission gear selector is placed in reverse.

REAR VIEW CAMERA

The cab chassis provided rear view box camera shall be installed on the rear of the body.

INTERIOR LED LIGHTS

Five (5) OnScene Solution model #70156, 10" x 10" x 7/8", 10-30 VDC, surface mount dual red and white LED light(s) with clear lens shall be provided throughout the vehicle. In addition light(s) will be capable of a five (5) second delay after switching off.

The light(s) shall be switched with high/low intensity setting at the entry door(s). An Innovative Controls black back-lit switch panel shall be provided to control specified lighting or other control switching.

A power source relay shall be provided to allow ceiling lights power battery direct when shore line power connected.

TAIL LIGHTS

Rear body tail lights shall be vertically mounted and located per Federal Motor Vehicle Safety Standards, FMVSS and Canadian Motor Vehicle Safety Standards CMVSS. The following lights shall be furnished;

- Two (2) Whelen M9 Series M9T amber LED turn signal lights
- Two (2) Whelen M9 Series M9BTTX red LED stop/tail lights
- Two (2) Whelen M9 Series M9BUW LED back-up lights with clear lens

Each light shall have a chrome flange.

MIDSHIP MARKER/TURN SIGNAL

Two (2) Whelen model T0A00MAR 2" round amber LED midship body clearance marker/turn signal lights shall be provided and installed, one (1) light on each side of the body, in forward wheel well of rear axle. Midship marker/turn lights shall be wired to the headlight circuit of the chassis.

MARKER LIGHTS

The body shall be equipped with all necessary side and rear clearance lights and reflectors in accordance with Federal Motor Vehicle Safety Standards (FMVSS) and Canadian Motor Vehicle Safety Standards (CMVSS). Clearance lights on body shall be connected to the clearance light circuit of the chassis.

REAR BUMPER MARKER LIGHTS

Two (2) Britax style dual face flexible mounted rear bumper markers shall be located, one (1) each side lower rear corner of body visible from driver mirrors.

CAB STEP LIGHTS / GROUND LIGHTS

The step lights and/or ground lights shall be supplied and installed by the cab/chassis manufacturer.

LICENSE PLATE LIGHT

One (1) Arrow #437 chrome plated LED license plate light shall be installed on the rear of the body. License plate light shall be wired to the headlight circuit of chassis. A fastener system shall be provided for license plate installation.

ELECTRONIC SIREN

The siren control head shall be supplied and installed by the cab/chassis manufacturer, if required by Houston Fire Department. Siren power shall be wired through the master warning light switch.

The specified siren functions shall be configured by cab chassis manufacturer.

SIREN SPEAKER

The siren speaker(s) shall be supplied and installed by the cab/chassis manufacturer.

FRONT CAB MOUNTED SCENE LIGHT(S)

Floodlight(s) shall be provided on the front of the cab by the cab/chassis manufacturer.

The lights shall be controlled at the multiplex display(s) in the cab.

REAR LED SCENE LIGHTS

Two (2) Whelen Pioneer Plus model PCH2 dual combination Super LED flood/spot lights shall be provided on upper rear body with white powdercoat paint finish. The PCH2 configuration shall consist of 36 white Super-LEDs with collimator/metalized redux spot/flood reflector assembly with Proclera™ silicone optics and a clear non-optic polycarbonate lens. Light(s) shall be 12 VDC, 13 amp, 75/75 watt, with 8,750/8,750 useable lumens each.

Each light shall be mounted in PBH203 mounting bracket, semi recessed into the apparatus body with chrome trim ring housing. The light mounts will provide either a straight out, 0 degree or a 15 degree downward angle.

The PCH2 is covered by a five year factory warranty.

The above scene lights shall light to a level of at least 3 fc (30 lx), measured at 25 equally spaced points on a 2.5 ft (750 mm) grid with in a 10 ft x 10 ft (3 m x 3m) square to the rear of vehicle.

The lights shall be controlled at the multiplex display(s) in the cab.

The rear scene lights shall also be activated when the apparatus is in reverse.

TRAFFIC ADVISOR LIGHTS

A traffic advisor system shall be provided on rear of vehicle using;

- Eight (8) Whelen Wide-angle ION series amber Super-LED lights with clear lens.
- Black flanges.
- Lights shall be individually mounted and evenly distributed.
- Centered vertically in a 4" non reflective, black 3M vinyl back ground.

The lights shall be controlled by the multiplexing system and provide; Left Arrow, Right Arrow, Center Out, and Wig-Wag patterns. The wig-wag light pattern shall be activated with the E-Master and can be switched to the other patterns at any time through the "TRAFFIC ADVISOR" menu on the Multiplex display.

DAVID CLARK INTERCOM SYSTEM

The following David Clark intercom system shall be provided and installed to improve the safety of firefighters and rescue professionals through enhanced communication and hearing protection.

The intercom system will go through four (4) individual Motorola radios, with intercom at five (5) positions; driver, officer, and the rear command seats. System shall have the following components as minimum;

- One (1) U3800 Master Station, 12 - 24 VDC
- One (1) U3805 Radio Cord Junction Module
- One (1) U3801 Intercom (Curbside rear seat)
- Four (4) U3815 Radio Interface/Headset Stations (Driver, Officer, (2) Desk Positions)
- Two (2) C38-12 Jumper Cords - 12'
- Three (3) C38-25 Jumper Cord- 25'
- One (1) C38-20 Power Cords - 20'
- One (1) C38-21-05 Cord 20', Radio Interface Module to U3805
- Five (5) H3442 Behind the Head Headsets with 6' Coil Cord, Mic ON/OFF.
- Two (2) #18352G-07 MS Connector 5-pin
- Two (2) #09851P-28 Push-To-Talk Switch DPST
- Two (2) #26553P-01 Guard PTT Switch
- One (1) #18900G-01 Washer, Neoprene (10/pk).
- One (1) 41021G-01 Multiple Radio Interface
- Four (4) C98-20RD, 20'
- One (1) 40892G-14 (C98-20MR2) System Interface Cable.
- One (1) 40892G-02 (C98-20PW) Power Cable.

INTERCOM SYSTEM INSTALLATION

The above listed intercom system shall be installed in the cab locations as follows;

Driver, officer, and streetside desk seats to have PTT capability and curbside desk and jump seat to have intercom only. Total of five (5) positions, three (3) PTT, two (2) intercom only. Desk positions jacks shall be located on desk top behind laptop mounts with storage hooks located under desktop.

Note: The location of the intercom systems headsets & plug-ins will be similar to the photos of the last truck with exception noted above and match the installation done by Metro Fire. All exposed wiring shall be provided with aesthetic covers.

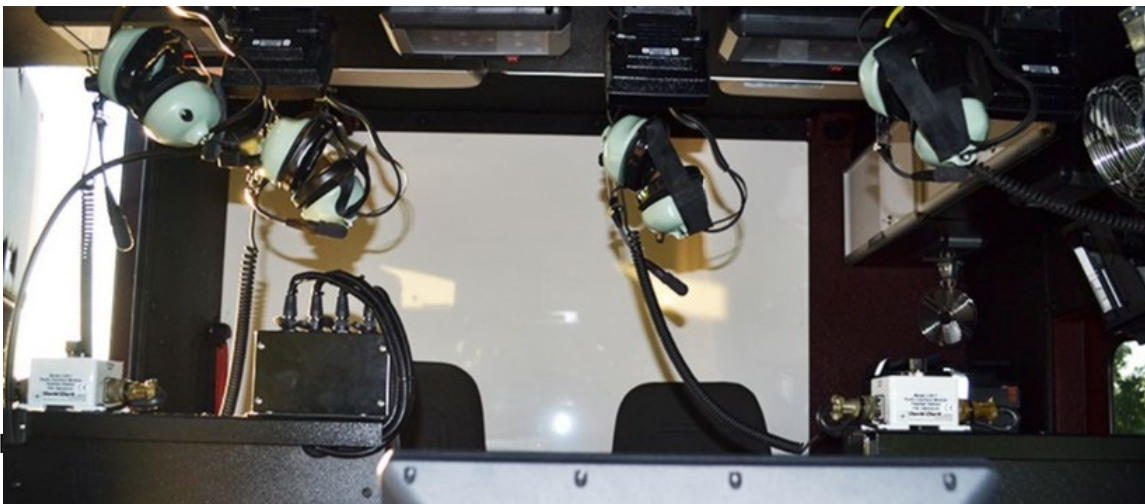

WARNING LIGHT PACKAGE

UPPER LEVEL OPTICAL WARNING DEVICES

The upper-level optical warning devices shall be mounted as high and as close to the corner points of the apparatus as is practical to define the clearance lines of the apparatus. The upper-level optical warning devices shall not be mounted above the maximum height, specified by the device manufacturer.

ZONES B AND D - SIDE WARNING LIGHTS

UPPER REAR CORNER WARNING LIGHTS

There shall be two (2) Whelen M9 linear super-LED Light(s) with full-fill optic provided, one (1) each side. The light head shall include an integral flasher with programmable flash patterns and Hi/Lo intensities. Component shall be covered by a five year Whelen factory warranty.

Each Light shall have:

- Red LEDs
- Clear Lens

Each light shall have a chrome flange.

- Flash Pattern shall be DOUBLEFLASH 150, In/Out

The lights shall be controlled at the multiplex display(s) in the cab.

UPPER FORWARD CORNER WARNING LIGHTS

There shall be two (2) Whelen M9 linear super-LED Light(s) with full-fill optic provided, one (1) each side. The light head shall include an integral flasher with programmable flash patterns and Hi/Lo intensities. Component shall be covered by a five year Whelen factory warranty.

Each Light shall have:

- Red LEDs
- Clear Lens

Each light shall have a chrome flange.

- Flash Pattern shall be DOUBLEFLASH 150, In/Out

The lights shall be controlled at the multiplex display(s) in the cab.

ZONE C - REAR WARNING LIGHTS

There shall be two (2) Whelen M9 linear super-LED Light(s) with full-fill optic provided, one (1) each side. The light head shall include an integral flasher with programmable flash patterns and Hi/Lo intensities. Component shall be covered by a five year Whelen factory warranty.

Each Light shall have:

- Red LEDs
- Clear Lens

Each light shall have a chrome flange.

- Flash Pattern shall be DOUBLEFLASH 150, In/Out

The lights shall be controlled at the multiplex display(s) in the cab.

LOWER LEVEL OPTICAL WARNING DEVICES

To define the clearance lines of the apparatus, the optical center of the lower-level optical warning devices in the front of the vehicle shall be mounted on or forward of the front axle centerline and as close to the front corner points of the apparatus as is practical.

The optical center of the lower-level optical warning devices at the rear of the vehicle shall be mounted on or behind the rear axle centerline and as close to the rear corners of the apparatus as is practical. The optical center of any lower-level device shall be between 18 in. and 62 in. (460 mm and 1600 mm) above level ground for large apparatus, and 18 in. and 48 in. (460 mm and 1600 mm) above level ground.

A midship optical warning device shall be mounted right and the left sides of the apparatus if the distance between the front and rear lower-level optical devices exceeds 25 ft (7.6 m) at the optical center. Additional midship optical warning devices shall be required, where necessary, to maintain a horizontal distance between the centers of adjacent lower-level optical warning devices of 25 ft (7.6 m) or less. The optical center of any midship mounted optical warning device shall be between 18 in. and 62 in. (460 mm and 1600 mm) above level ground.

ZONE A - FRONT WARNING LIGHTS

The warning lights shall be supplied and installed by the cab/chassis manufacturer. They shall be Whelen lights to complete an NFPA compliant lower level warning light system.

- Flash Pattern shall be DOUBLEFLASH 150, In/Out

The lights shall be controlled at the multiplex display(s) in the cab.

ZONES B AND D - CAB INTERSECTOR LIGHT (CAB FRONT CORNERS)

The warning lights shall be supplied and installed by the cab/chassis manufacturer. They shall be Whelen lights to complete an NFPA compliant lower level warning light system.

- Flash Pattern shall be DOUBLEFLASH 150, In/Out

The lights shall be controlled at the multiplex display(s) in the cab.

ZONES B AND D - BODY LIGHT (BODY WHEELWELL AREA)

There shall be two (2) Whelen M6 linear super-LED Light(s) with full-fill optic provided, one (1) each side. The light head shall include an integral flasher with programmable flash patterns and Hi/Lo intensities. Component shall be covered by a five year Whelen factory warranty.

Each Light shall have:

- Red LEDs
- Clear Lens

Each light shall have a chrome flange.

- Flash Pattern shall be DOUBLEFLASH 150, In/Out

The lights shall be controlled at the multiplex display(s) in the cab.

ZONES B AND D - BODY INTERSECTOR LIGHT (BODY REAR CORNERS)

There shall be two (2) Whelen M6 linear super-LED Light(s) with full-fill optic provided, one (1) each side. The light head shall include an integral flasher with programmable flash patterns and Hi/Lo intensities. Component shall be covered by a five year Whelen factory warranty.

Each Light shall have:

- Red LEDs
- Clear Lens

Each light shall have a chrome flange.

- Flash Pattern shall be DOUBLEFLASH 150, In/Out

The lights shall be controlled at the multiplex display(s) in the cab.

ZONE C - REAR WARNING LIGHTS (LOWER REAR CORNERS)

There shall be two (2) Whelen M9 linear super-LED Light(s) with full-fill optic provided, one (1) each side. The light head shall include an integral flasher with programmable flash patterns and Hi/Lo intensities. Component shall be covered by a five year Whelen factory warranty.

Each Light shall have:

- Red LEDs
- Clear Lens

Each light shall have a chrome flange.

- Flash Pattern shall be DOUBLEFLASH 150, In/Out

The lights shall be controlled at the multiplex display(s) in the cab.

LINE VOLTAGE ELECTRICAL SYSTEM

HYDRAULIC GENERATOR SYSTEM

A Harrison HydraGen model 20.0MPC-16D, hydraulic driven generator set shall be installed on the vehicle. The generator shall be rated at 20,000 watts at 120/240 VAC, 166/83 amps, single phase. Current frequency shall be stable at 60 hertz.

If the hydraulic generator system is not capable of output as stated on the power source specification label at all engine speeds, an automatic engine speed control system shall be provided.

If the vehicle is equipped with a fire pump driven by the chassis engine, the generator shall be capable of output as stated on the power source specification label with the engine at idle.

GENERATOR BONDING

A minimum of four (4) 16" x 2 gauge copper ground straps shall be bolted to body sub-frame and chassis sub-frame for proper bonding of high voltage system. The conductor shall have a minimum amperage rating, as defined in 310.15, "Ampacities for Conductors Rated 0–2000 Volts," of *NFPA 70*, of 115 percent of the rated amperage on the power source specification label.

GENERATOR MOUNTING

The hydraulic generator module shall contain all system components necessary to comprise a complete hydraulic generating system. The components shall be grouped and assembled into a compact modular unit.

The generator unit shall be modular, packaged with a heavy steel protective frame. All connections to the module (both hydraulic and electrical) shall be easily removable for easy removal of unit from compartment.

Hydraulic oil reservoir and filter shall be easily accessible with adequate clearance to facilitate oil filling and filter changing.

WARRANTY PERIOD

Provided such goods are operated and maintained in accordance with Harrison's written instructions, Harrison warrants that the MPC series hydraulic generators shall be free from defects in material and workmanship for a period of two (2) years or two thousand (2,000) hours, whichever comes first, from the date of delivery to the first purchaser.

HYDRAULIC COMPONENTS

A hydraulic system filter and strainer shall be provided and shall be located in a readily accessible area.

Hydraulic hose shall meet the hydraulic pump manufacturer's recommendations for pressure, size, vacuum, and abrasion resistance. Hydraulic fittings shall meet the hydraulic pump manufacturer's recommendations for pressure, size, and the type of hose used.

Where the hydraulic hose comes into contact with other surfaces, the hose shall be protected from chafing.

GENERATOR CONTROL

The generator shall be engaged at the multiplex display(s) in the cab.

GENERATOR MOUNTING

The generator shall be mounted in a lower exterior compartment on rubber vibration isolators. The compartment shall be reinforced where necessary to hold weight of generator. A valve shall be provided on the generator oil drain outlet and piped to underside of generator compartment with flexible hose and plug. The drain shall be located where easily accessible for generator service.

MANUALS AND SCHEMATICS

Two (2) complete manuals on parts list, maintenance, wiring schematics, hydraulic schematics, circuit boards, voltage regulator board and other components shall be provided on delivery.

POWER-TAKE-OFF GENERATOR DRIVE

There shall be a "Hot Shift" power-take-off (PTO) installed on the transmission PTO opening of the chassis. The "Hot Shift" PTO is provided to allow the engagement of the PTO at higher engine RPM speeds. The PTO output shall be connected to the generator through hollow tube type driveline with heavy duty universals.

The engagement of the PTO shall be in the chassis cab with a rocker switch and red pilot light to note engagement of the PTO or via the V-Mux screen if so equipped.

The power supply to the PTO engagement control shall be wired to the parking brake and a neutral position transmission switch to prevent engagement unless the vehicle is stopped and transmission has been placed in neutral.

The installation of the engine, transmission, driven accessories (power takeoffs (PTO), etc.) shall meet the engine and transmission manufacturers' installation recommendations for the service intended.

Model part number shall be Chelsea 280 series.

LOADCENTER

The loadcenter shall be an Eaton BR Series specifically designed for protection and distribution of AC line voltage such as lighting and small motor branch circuits. The loadcenter enclosure is made of 16 gauge galvanized sheet steel with a galvanized coating provided for corrosion protection. All trims used on BR loadcenters are chromate sealed and finished with an electro-disposition epoxy paint (ANSI-61) which exceeds requirements for outdoor and indoor applications. A combination surface/flush cover with integral door is supplied with indoor loadcenters rated from 100 through 400 amperes. All plug-in loadcenters are CSA listed to file LL98266. CSA Certified to C22.2 No.29, to loadcenter type and CSA listing.

GENERATOR MONITORING PANEL

To properly monitor the generator performance and load demand during operation, the generator installation shall be equipped with a full instrument monitor panel.

- Generator frequency in hertz
- Line 1 current in amperes
- Line 2 current in amperes
- Generator voltage in volts

The program shall support the accumulation of elapsed generator hours. Generator hours shall be displayed.

Unit to be located below 120/240 VAC distribution panel at interior IS2 location.

SHORE POWER INLET - AIR CONDITIONER UNITS

To protect both the generator and external power source from back feed, two (2) 120 volt, 30 ampere, 4PST auxiliary contact with safety interlock relay shall be installed. Relay shall cut-off the connection between the generator supply circuit and device circuits when shore power is connected.

Transfer equipment, including transfer switches, shall operate such that all ungrounded conductors of one power source are disconnected before any ungrounded conductors of the second power source are connected. The neutral conductor shall be switched through the transfer switch. The apparatus shall have a label permanently affixed at the power inlet that indicates the line voltage, and amperage.

SHORE POWER INLET

One (1) Kussmaul 120 VAC, 30 amp Super Auto-Eject shore power inlet(s) shall be provided. The shore power connection shall automatically disengage from vehicle when chassis ignition is engaged.

The protective ground from the shoreline inlet shall be bonded to the vehicle frame.

- The outlet cover shall be blue.

Stainless steel scuff panel shall be provided behind shore power inlet.

- The shore power inlet shall be located on the **CURBSIDE** rear of the body.

Shore power shall be wired to the specified 120 VAC air conditioning unit(s) and capable of switching between; Zone 1 - streetside cab roof and forward body air conditioners, or Zone 2 - curbside cab roof and middle body airconditioners.

SHORE POWER INLET - SPECIFIED CIRCUITS

A transfer switch shall be required to isolate one power source from the other where a circuit(s) is intended to be supplied from more than one power source. To protect both the generator and external power source from back feed, two (2) 120 volt, 30 ampere, 4PST auxiliary contact with safety interlock relay shall be installed. Relay shall cut-off the connection between the generator supply circuit and device circuits when shore power is connected.

Transfer equipment, including transfer switches, shall operate such that all ungrounded conductors of one power source are disconnected before any ungrounded conductors of the second power source are connected. The neutral conductor shall be switched through the transfer switch. The apparatus shall have a label permanently affixed at the power inlet that indicates the line voltage, and amperage.

SHORE POWER INLET

One (1) Kussmaul 120 VAC, 20 amp Super Auto-Eject shore power inlet(s) shall be provided. The shore power connection shall automatically disengage from vehicle when chassis ignition is engaged.

The protective ground from the shoreline inlet shall be bonded to the vehicle frame.

- The outlet cover shall be red.
- The shore power plug shall be located near the Driver door area.

Shore power inlet shall be wired to the following specified 120 VAC circuits;

Shore power shall be wired to all primary 120 VAC, 20 ampere electrical outlets on apparatus (maximum of two (2) circuits). Circuits shall be provided with circuit breaker protection with either generator or shore power providing power.

Receptacle Label

Each receptacle shall be marked with a label indicating the nominal line voltage (120 volts or 240 volts) and the current rating in amps of the circuit. If the receptacle is DC or other than single phase, that information shall also be marked on the label.

All receptacles and electrical inlet devices shall be listed to UL 498, *Standard for Safety Attachment Plugs and Receptacles*, or other recognized performance standards.

Receptacles used for DC voltages shall be rated for DC service.

Wiring Schematics

An "As-Built" Wiring diagrams for line voltage systems shall be provided to include the following information;

- (a) Pictorial representations of circuit logic for all electrical components and wiring
- (b) Circuit identification
- (c) Connector pin identification
- (d) Zone location of electrical components
- (e) Safety interlocks
- (f) Alternator–battery power distribution circuits
- (g) Input/output assignment sheets or equivalent circuit logic implemented in multiplexing systems

120/240 VAC SCENE LIGHTING

SIDE UPPER RECESSED SCENE LIGHTS

Four (4) Whelen Pioneer+ model PFP2AC LED dual floodlight(s) with white powder coated aluminum housing shall be provided and installed. Light quantity shall be divided equally per side. Lights shall be 120 VAC, 1.25 amp, 150 watt with 72 white Super-LEDs, clear optic collimator/reflector assembly, and clear non-optic polycarbonate lens. The Pioneer flood light shall have 15,000 usable lumens. The PFP2AC is UL® approved and covered by a five year factory warranty.

Each light shall be mounted in PBA203 mounting bracket, semi recessed into the apparatus body with chrome trim ring housing. The light mounts shall provide either a straight out, 0 degree or a 15 degree downward angle.

NOTE: ORDER (2) EACH OF MODEL PFP2ASF AND (2) EA OF MODEL PFP2AFS. MOUNT SPOT SIDE OF THIS LIGHT OUTBOARD ON EACH SIDE OF BODY.

The lights shall be switched at the multiplex display(s) in cab.

- The above lights shall also be controlled by one (1) rocker switch(es). The rocker switch(es) shall be located in the cab within reach of Officer.

LIGHT TOWER INSTALLATION

The completed vehicle shall be supplied with one (1) all-electric Command Light flood light tower(s). The unit shall not require tapping into vehicle braking system to be operated, eliminating the chance for vehicle brake problems. Hydraulic or pneumatic type floodlights are not acceptable alternatives to the all-electric light tower specified.

The Command Light light tower(s) shall be purchased and supplied by the Houston Fire Department or dealer to the OEM body builder.

The light tower controls shall be located per the itemized compartment list.

A red flashing or rotating light located in the driving compartment shall be illuminated automatically whenever the vehicles parking brake is not fully engaged, indicating that the light tower is not in stowed position, as required by NFPA 1901.

Dealer supplying a CL602A w/backlight.

Light Tower Mounting

The specified light tower(s) shall be mounted on the roof of the body.

Where the light tower is to be mounted above a finished walk-in area; the roof backing plates and structure shall have threaded holes to allow removal of light tower without removal of the interior paneling.

Where the light tower is mounted in close proximity to other roof mounted Items (i.e. antennas, air conditioners, and weather stations) the light tower shall be orientated in order to help prevent a operator driven collision.

EQUIPMENT PAYLOAD WEIGHT ALLOWANCE

In compliance with NFPA 1901 standards, the special service vehicle shall be designed for an equipment loading allowance of 6,000 lbs. of Houston Fire Department provided equipment based on a 40,001 - 50,000 pound gross vehicle weight rating.

EQUIPMENT

The following equipment shall be furnished with the completed special service vehicle;

- One (1) container of assorted stainless steel nuts, bolts, screws and washers used in the construction of the apparatus shall be provided with the completed apparatus.
 - The wheel chock(s) shall be the responsibility of Houston Fire Department after delivery of completed apparatus.