

GENERAL SPECIFICATIONS:

1. FORD F450 CHASSIS WITH 108" CA / 193.3" WHEEL BASE. (F350 NOT AVAILABLE IN 108" CA)
2. TWO (2) 30" PPV FANS, STORED ONE (1) EA SIDE BEHIND RAMP DOORS.
3. OVERHEAD TRANSVERSE STORAGE BIN FOR TWO (2) 30" Ø DUCTS.
4. STORAGE BETWEEN SVU-50 AND FRONT COMPARTMENT FOR UP TO TWO (2) 30" Ø DUCTS.
5. STORAGE IN TRANSVERSE AREA BETWEEN 30" PPV FANS FOR SVU-50 INTAKE ADAPTER TO 30" DUCT.
6. STORAGE AND CONTROL BOXES AT REAR OF BED (BEHIND SVU-50 FOR EXTENSION CORDS AND SVU-50 CONTROLS).

PRELIMINARY DRAWING - FOR LAYOUT PURPOSES ONLY

REVISIONS			
REV	DESCRIPTION	DATE	BY

NOTE 1: Do not scale drawing. This drawing is for general truck configuration only. All items and dimensions shown are approximate and may vary with final production. The drawing may not provide illustration for all items in the specification. In all situations where the drawing may contradict the specifications, the specifications shall prevail. This drawing and all data herein are provided as confidential materials and shall not be reproduced without written consent of the manufacturer.

NOTE 2: Chassis frame height will change due to axle characteristics, loading and tire dimensions which will effect the overall height dimension shown. Any overall height restrictions should take this into consideration and allow approximately 2-3 inches of tolerance.

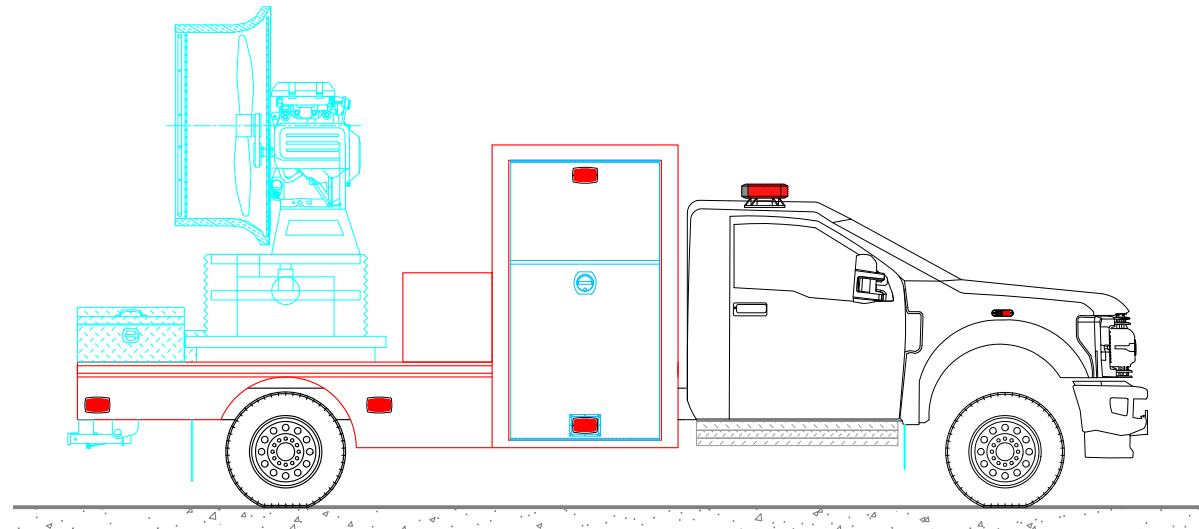
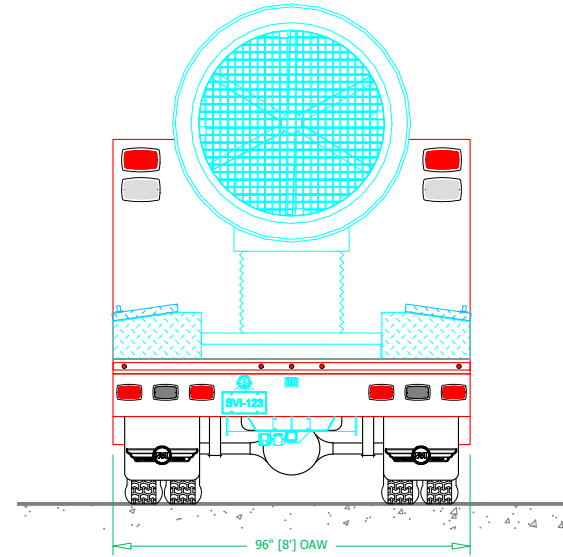
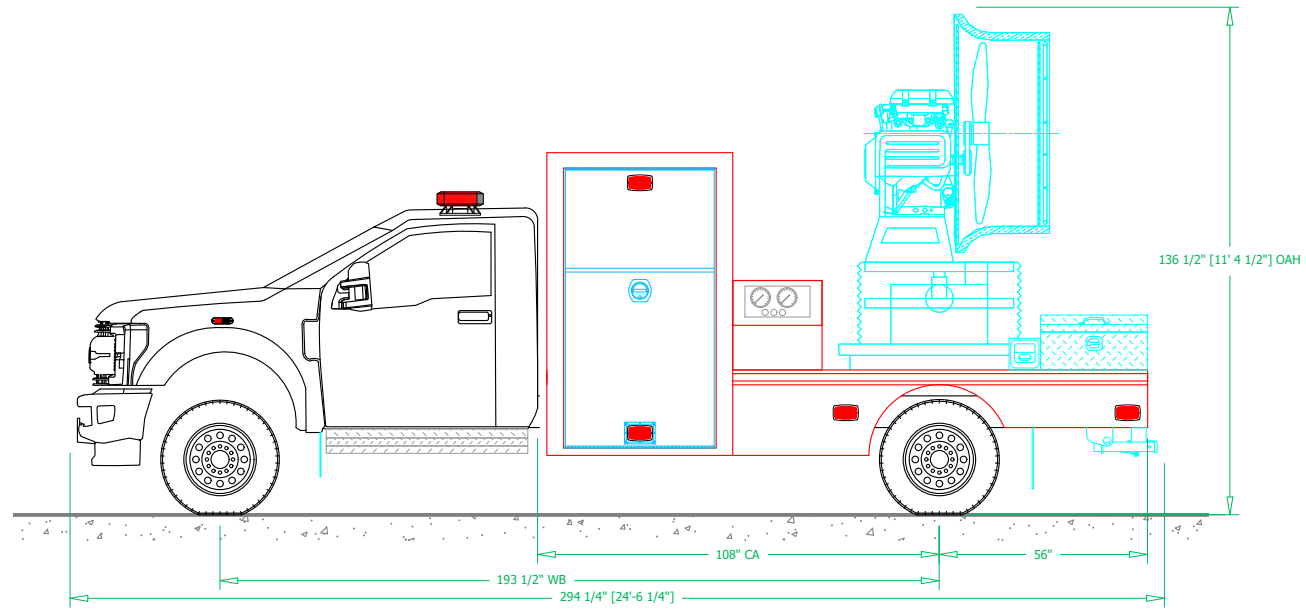
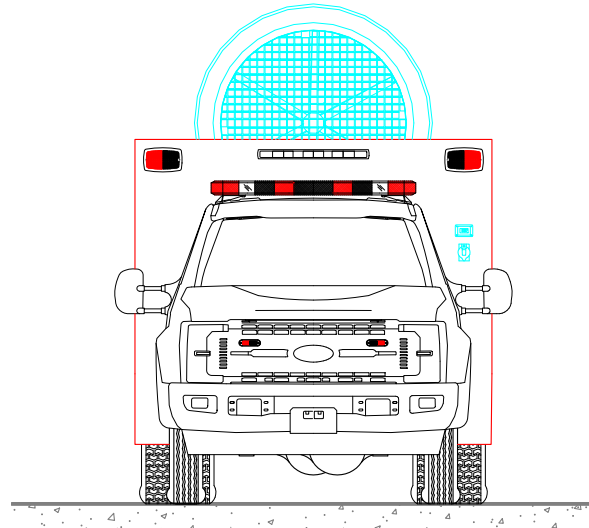
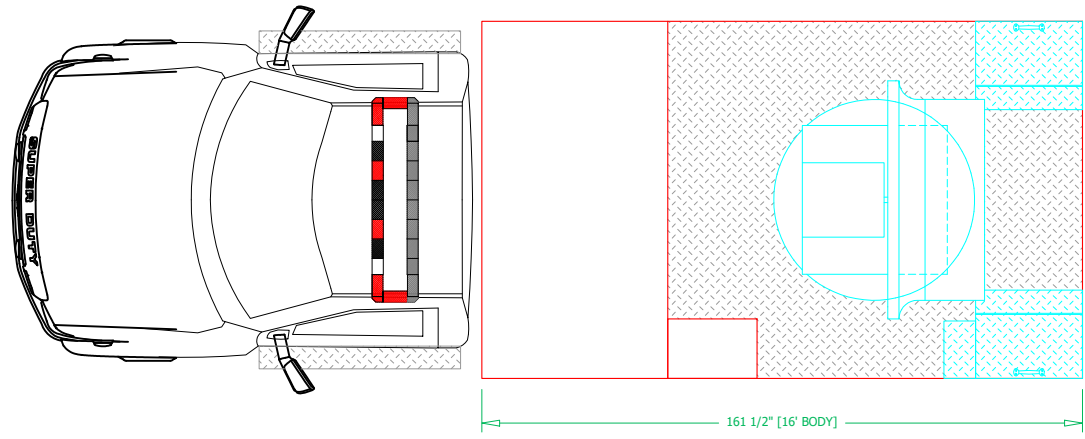

SUPERVAC

SUPER VACUUM MANUFACTURING
3842 REDMAN DRIVE; FT COLLINS, CO 80524; PH(970)297-7100; www.supervac.com

WASHINGTON DC FIRE DEPARTMENT

BODY SIZE: 16'	UNIT TYPE: SVU-50
BODY MATERIAL: 1/8" ALUM. TREADPLATE	TRUCK NO: XXXX
CHASSIS TYPE: FORD	WHEELBASE: SEE DWG
F550	CAB TO AXLE: SEE DWG
2 DOOR	OVERALL LENGTH (OAL): SEE DWG
4X4	OVERALL WIDTH (OAW): 96"
	OVERALL HEIGHT (OAH): SEE DWG

DRAWN BY: JOHNB DATE: May 1, 2024 SCALE: 1/4" = 1'-0"
DRAWING NO: DCFD_SVU_Prelim4 SHEET 1 OF 2

PRELIMINARY DRAWING - FOR LAYOUT PURPOSES ONLY

REVISIONS			
REV	DESCRIPTION	DATE	BY

NOTE 1: Do not scale drawing. This drawing is for general truck configuration only. All items and dimensions shown are approximate and may vary with final production. The drawing may not provide illustration for all items in the specification. In all situations where the drawing may contradict the specifications, the specifications shall prevail. This drawing and all data herein are provided as confidential materials and shall not be reproduced without written consent of the manufacturer.

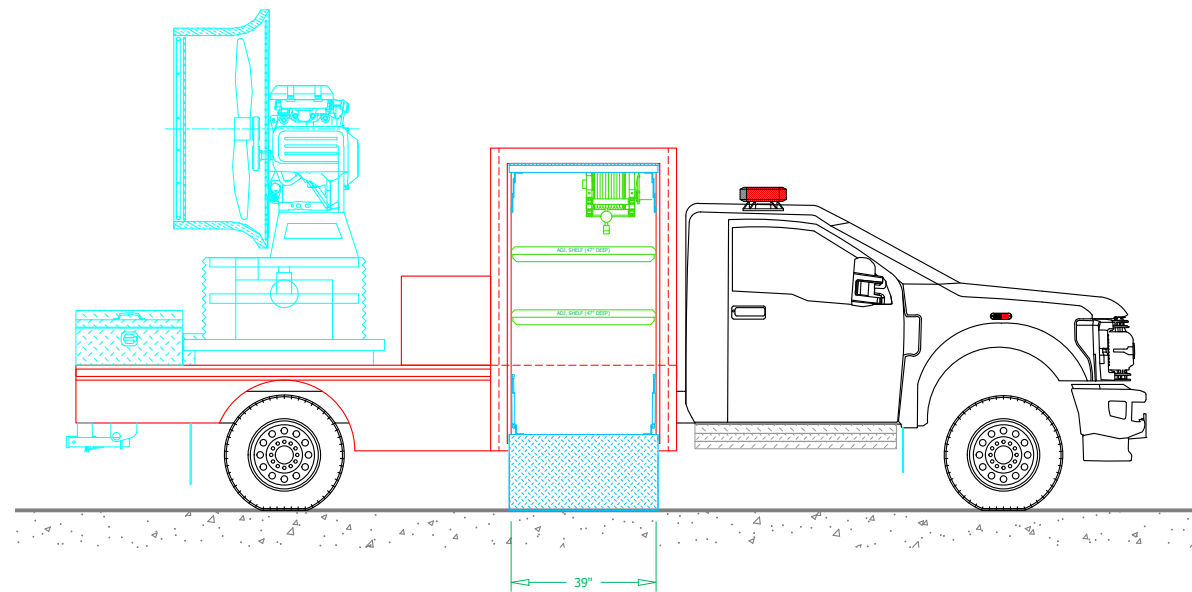
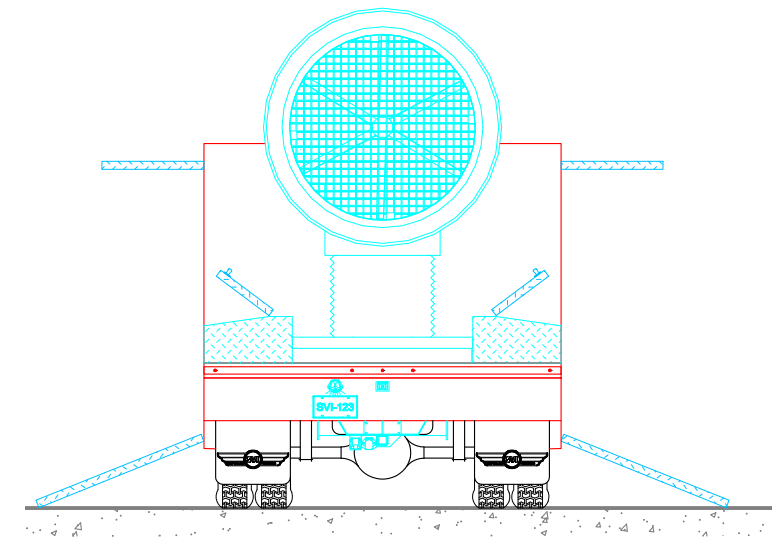
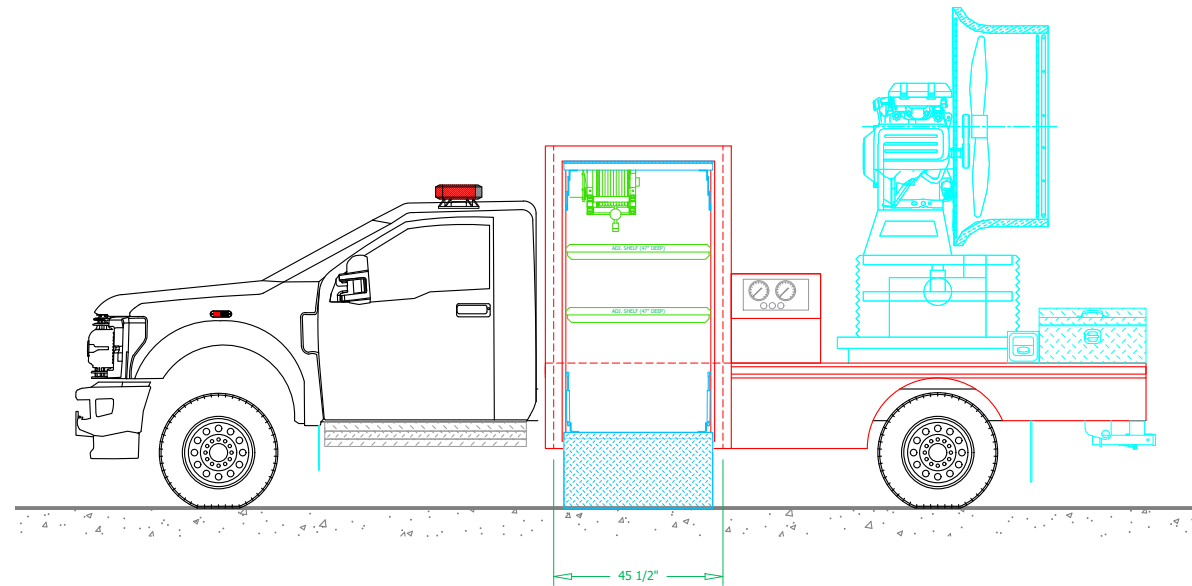

SUPERVAC 

SUPER VACUUM MANUFACTURING
3842 REDMAN DRIVE, FT. COLLINS, CO 80524; PH (970)297-7100; www.supervac.com

WASHINGTON DC
FIRE DEPARTMENT

DRAWN BY: JOHN B DATE: May 1, 2024 SCALE: 1/4" = 1'-0"
DRAWING NO: DCFD_SVU_Prelim4 SHEET 2 OF 2